

HTE

OMP

OMP

[ **CAR PARTS** | 2026 CATALOG ]

OMP

# RACING FORCE GROUP



DISCOVER ALL OUR COLLECTIONS



**OMP RACEWEAR**  
2026 CATALOG



**OMP CAR PARTS**  
2026 CATALOG



**BELL HELMETS**  
2026 CATALOG



**ZERONOISE**  
2026 CATALOG



**RACING SPIRIT**  
2026 CATALOG



# THE GROUP

We in words

Racing Force Group is the global leader in motorsport safety, innovation, and performance. Through its portfolio of brands – including OMP, Bell Racing, Zeronoise, and Racing Spirit – equips professional drivers, teams, and manufacturers, as well as passionate amateurs, with racewear, helmets, car parts, communication systems, and technical apparel.

Racing Force Group is the only company in the motorsport industry to offer such a comprehensive range of products, contributing each year to numerous victories and titles in both car and kart racing. The Group has also diversified through its HPS brand, applying cutting-edge motorsport technologies to the defense sector. After successfully completing the integration of its brands, Racing Force became a dual-listed company. Since November 2021, it has been listed on the Euronext Growth Milan market (RFG) and, as of September 2022, on the Euronext Growth Paris market (ALRFG). Racing Force Group thus became the first company in its sector to trade its shares publicly.

The Group has a global presence across three continents, with headquarters in Ronco Scrivia (Italy), Sakhir (Bahrain), Mooresville (USA) and Tubize (Belgium). It operates research and production centers, logistics hubs, and Pro-Shops, and employs over 600 people from more than 35 nationalities. Racing Force relies on well-established relationships with professionals worldwide, selling its products in over 80 countries, supported by the largest dealer and distributor network in the motorsport industry.

The Group's core values and work ethics are centered around integrity, respect, dedication, determination, diversity, sound judgment, dependability, accountability, teamwork, loyalty, quality, and safety. Racing Force Group achieves success through a positive mental attitude, optimism, vision, courage, proactiveness, and passion - its true driving force.

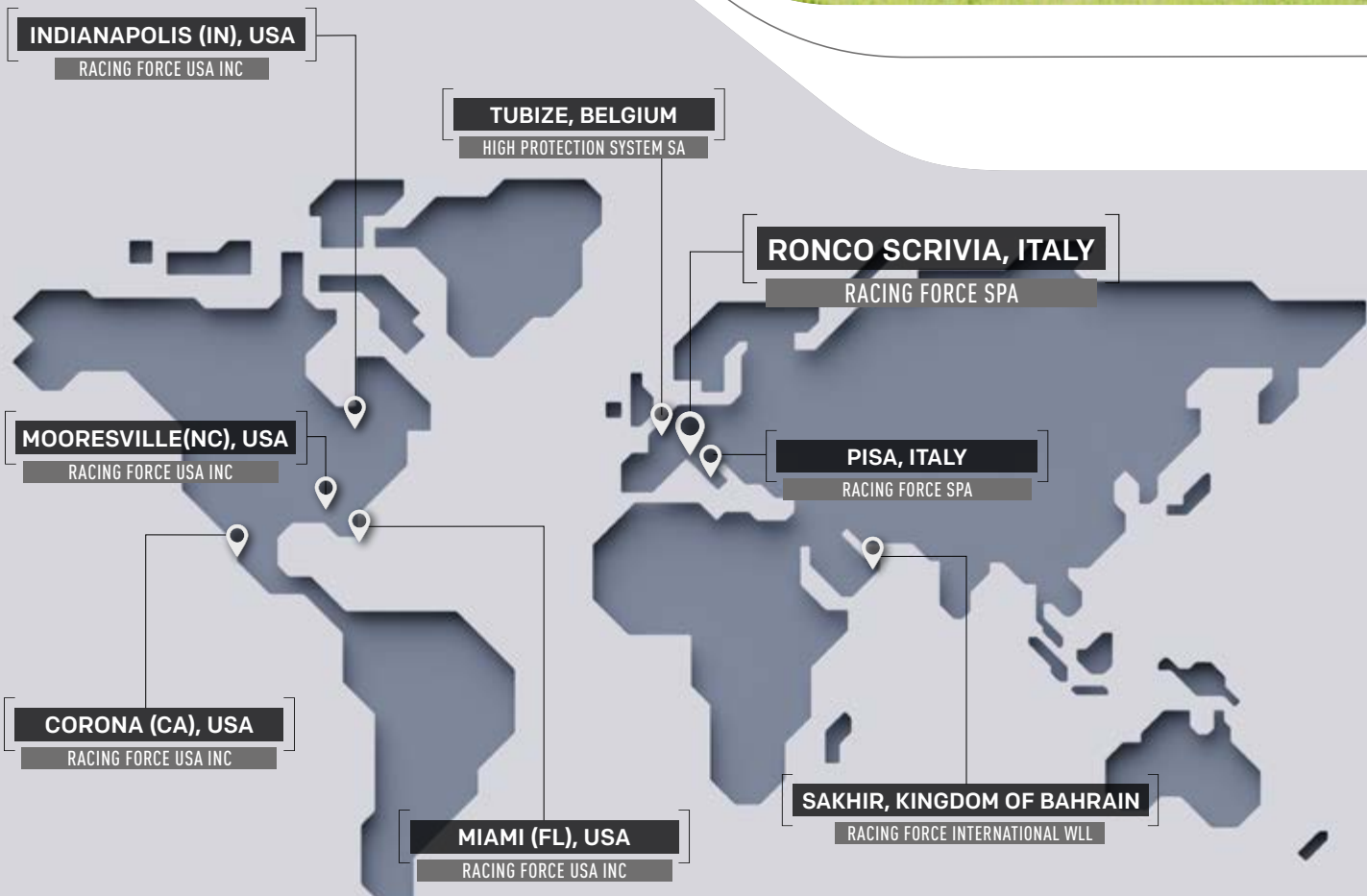

## We in numbers

SALES IN **85+** COUNTRIES | **+60039** EMPLOYEES OF **39** NATIONALITIES

**8** LOCATIONS  
**8** PRO - SHOPS  
**3** R&D CENTERS

MORE THAN **2.000** PRODUCTS | CORPORATE AND **SOCIALLY RESPONSIBLE**

**2.000.000+** PIECES SHIPPED EVERY YEAR

PRODUCTS HOMOLOGATED BY **FIA | CIK-FIA | SFI | SNELL**



RACINGFORCEGROUP



# THE BRANDS



## OMP

Founded in 1973 in Genoa, Italy, OMP is a global leader in motorsport safety, specializing in the design and production of racewear, car parts, and accessories. As one of the few industry players capable of delivering such a comprehensive range of products, OMP adheres to the most stringent homologation standards, including the ones from FIA, CIK-FIA, SFI, and Snell. With a legacy of achievements and continuous innovation, OMP has collaborated with motorsport icons like Ayrton Senna and Michael Schumacher, contributing to world titles across multiple championships and disciplines, between circuit racing, rallying and karting.



## BELL RACING HELMETS

Bell Racing Helmets is the world's leading supplier of helmets across all forms of car racing, including circuit, rally, and dirt racing. Founded in 1954 in the United States, Bell still remains benchmark for safety, innovation, performance, and engineering excellence, delivering the most advanced line of auto racing helmets globally. From the very beginning, Bell helmets have been trusted by more champions across all racing disciplines than any other brand, solidifying its reputation as the most iconic name in head protection for motorsport.



## ZERONOISE

Established in 2019, Zeronoise is the electronics division of Racing Force Group, specializing in the engineering, development, and manufacturing of communication technology for the sports industry. Zeronoise's product range includes intercom systems for rally racing and the patented Driver's Eye - the world's most compact real-time TV broadcasting microcamera, utilized in some of the most prestigious motorsport competitions. Through its joint venture with Al Kamel Systems, Zeronoise also offers advanced timekeeping, TV graphics, data management, and race control solutions, further enhancing the accuracy and entertainment value of motorsport events.



## RACING SPIRIT

Racing Spirit was created with a clear mission: to channel the passion and heritage of OMP - a brand that has worked alongside the most successful teams and drivers for over fifty years - into premium clothing and accessories. Forged in the fiercely competitive world of motorsport, Racing Spirit has also become a trusted name in other demanding sectors, such as boating. The brand offers a comprehensive collection of apparel for men and women, designed and developed in Italy, blending style, comfort, performance, and functionality.



# PARTNER OF THE FIA

FIA Motorsport



For over a decade, Racing Force Group and the FIA have been jointly committed to ensuring the protection of people in motorsport. This collaboration began in 2012 with the first deal between OMP and the sport's governing body, and was further strengthened with the involvement of Bell Racing Helmets.

FIA Motorsport



Safety equipment for FIA officials and safety car drivers in every FIA World Championship is exclusively provided by the Racing Force Group brands: OMP for fireproof suits, shoes, gloves, and underwear, and Bell Racing for helmets.

FIA Karting Academy



Furthermore, since 2017, OMP has served as the official supplier to the young talents of the FIA Karting Academy Trophy, now structured into Junior and Senior championships.

# ALWAYS PUSHING THE LIMITS



**1973**

OMP history begins with a Fiat 500 rollbar. Since then, OMP gets noticed more and more, becoming official car parts supplier for many Italian teams and manufacturers.



**1982**

OMP diversifies its production, entering the racewear market. The company soon supplies its first Formula 1 driver: Mauro Baldi of Arrows team.



**1986**

OMP is the world's first company to obtain the new FIA ISO 86 homologation standards for fireproof racing suits.



**1989**

Gerhard Berger survives the flames of his Ferrari, after the crash during the F1 race at Imola. Credit goes to fireproof overalls and gloves made by OMP. Millions of people see those moments on live TV, and the company becomes popular all over the world.



**1990**

OMP supplies F1 star Ayrton Senna. The partnership will last until the death of the legendary Brazilian driver, with 20 race victories and two world F1 titles scored together.



**1996**

Michael Schumacher kicks off his Ferrari era choosing OMP overalls and gloves. It's the start of a historic collaboration, sharing 71 wins and five F1 world titles.



**1999**

OMP ends in style the 20th century, celebrating the fourth consecutive World Rally Championship title along with the Mitsubishi Ralliart team and Tommi Mäkinen.



**2008**

In February the control of OMP is acquired by SAYE S.P.A. Group, held by Delprato brothers from Genova.



**2010**

OMP returns to Formula 1, signing an agreement with Renault F1 Team to supply its first safety belts designed and built entirely by its R&D department.



**2012**

OMP conquers the US celebrating its maiden IndyCar Series title with Andretti Autosport driver Ryan Hunter-Reay.



**2013**

Volkswagen Motorsport opens a four-year WRC domination with Sebastien Ogier and OMP. It's the first of many world titles for the HTE seat.



**2013**

OMP provides the drivers' overalls for award-winning "Rush" movie directed by Ron Howard, reproducing in detail the 1976 F1 season look.



**2016**

OMP marks a revolution in the karting sector with the launch of the first ever fully printed suit, the KS1. A new partnership with OTK Group, owner of the Tony Kart brand, also begins.

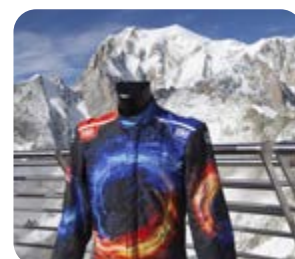

**2017**

OMP presents "One Art", the first totally customized fire retardant suit. The Print Art technology guarantees complete control of the design process.



**2017**

OMP harnesses are chosen by Mercedes AMG Petronas Motorsport Team, which extends its Formula 1 Manufacturers' World Championships streak till the 2021 season.

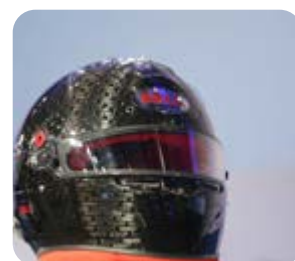

**2019**

OMP acquires Bell Racing Helmets, giving birth to the biggest worldwide player in motorsport safety equipment.



**2021**

OMP and Bell Racing unite under the newly formed Racing Force Group, together with emerging brands Zeronoise and Racing Spirit, strengthening their leadership in the safety industry.



**2022**

MotoGP legend Valentino Rossi begins his full-time car racing career, using OMP racewear and Bell helmets through a multi-year partnership.



**2022**

OMP supplies Toyota Gazoo Racing WRT for the third World Rally Championship Manufacturers' title in five years, while Kalle Rovanpera becomes youngest ever WRC champion.

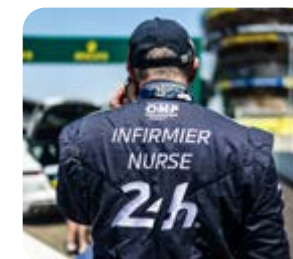

**2023**

OMP becomes official partner of the 24 Hours of Le Mans and the FIA, supplying safety gear for marshals, safety-car drivers, doctors, and all the on-track personnel.

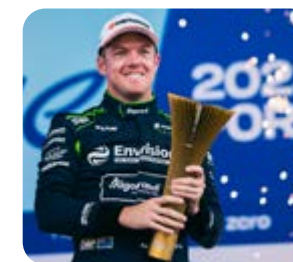

**2023**

Envision Racing wins an historic FIA Formula E Teams' World Championship using the OMP racewear for its drivers.

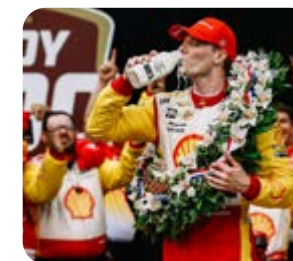

**2024**

As a new partner of Team Penske, the most successful racing stable in America, OMP celebrates victories at the 2024 Indianapolis 500 and secured its first-ever NASCAR Cup Series title.

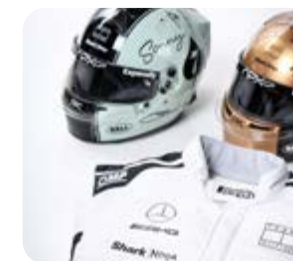

**2025**

OMP, together with Bell Racing and Racing Spirit, becomes an official partner of the highly anticipated Formula 1 movie. The collaboration includes supplying racewear, helmets, and team uniforms for lead actors Brad Pitt and Damson Idris, as well as the entire APX GP team.



**2025**

OMP enters a multi-year partnership with adidas Motorsport to provide racewear solutions, including race suits and gloves, engineered to meet the highest standards of performance and safety for drivers and teams.



**2025**

OMP introduces the revolutionary Air fabric technology for racewear, establishing a new benchmark with the launch of the One Art Air, the world's most breathable racing suit.



# SEATTS



# SEAT HOMOLOGATION STANDARDS

## **FIA 8862-2009 HIGH-TECH TOP LEVEL SEATS**

BEST SAFETY/WEIGHT RATIO HIGH-TECH CARBON FIBER AND FIBERGLASS SHELL.  
MANDATORY IN FIA WORLD CHAMPIONSHIP SUCH AS WRC, WEC AND OTHER TOP CATEGORIES.

SEE PAG. 16-25



## **FIA 8855-2021 HIGH-SAFETY STANDARD**

HIGH PROTECTION SHAPE 8862 INSPIRED REDUCED WEIGHT CARBON FIBER AND FIBERGLASS SHELL.

SEE PAG. 26-33



## **FIA 8855-1999 MOST WIDERSPREAD RACING SEAT RANGE**

THREE MAIN MATERIALS: ENTRY LEVEL TUBULAR FRAME, MEDIUM RANGE FIBERGLASS SHELL OR THE LIGHTER CARBON FIBER SHELL.  
WIDE RANGE OF SHAPES SUITABLE FOR ANY TYPE OF SALOON CAR.

SEE PAG. 34-59



# HTE ONE ULTRA LITE

HA0-0829-A01 ON REQUEST

EXTREMELY ULTRA LIGHTWEIGHT  
VERSION OF HTE ONE LITE SEAT,  
AVAILABLE UPON REQUEST.

- Realized with exclusive technology for maximum resistance and lightness
- 3D fabric upholstery
- Upholstering customized on demand
- The use of supports homologated with the seat in accordance with the Technical List n°40 is compulsory
- The lightest available on the market

**THE LIGHTEST  
FIA 8862 - 2009 SEAT  
IN THE WORLD**

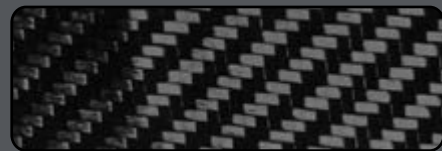

ULTRALIGHT CARBON FIBER



3D FABRIC UPHOLSTERING

**FIA 8862 - 2009**



MANUFACTURER: OMP  
MODEL: HTE ONE ULTRA LITE  
HOM. NO: AS.109.24  
FIA STANDARD: FIA 8862-2009

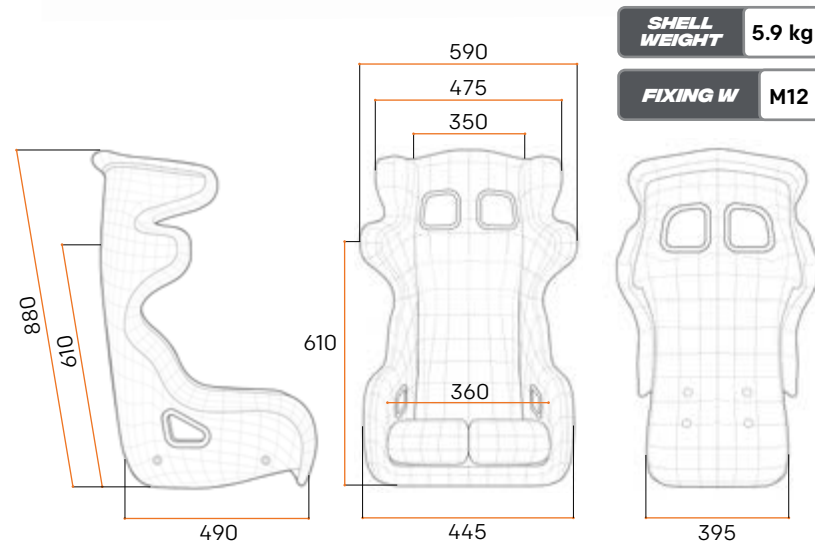

# HTE ONE LITE

HAO-0807-A01 € 10.300,00 (D)

## HIGH RESISTANT AND ULTRA LIGHTWEIGHT CARBON FIBER SEAT

- Realized with exclusive technology for maximum resistance and lightness
- 3D fabric upholstery
- Upholstering customized on demand
- The use of supports homologated with the seat in accordance with the Technical List n°40 is compulsory



EXTRA LARGE SHOULDER HARNESS SLOTS



SPLIT LEG REMOVABLE CUSHION

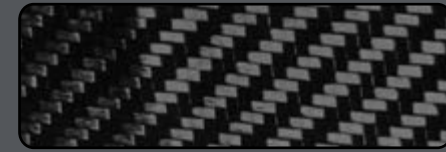
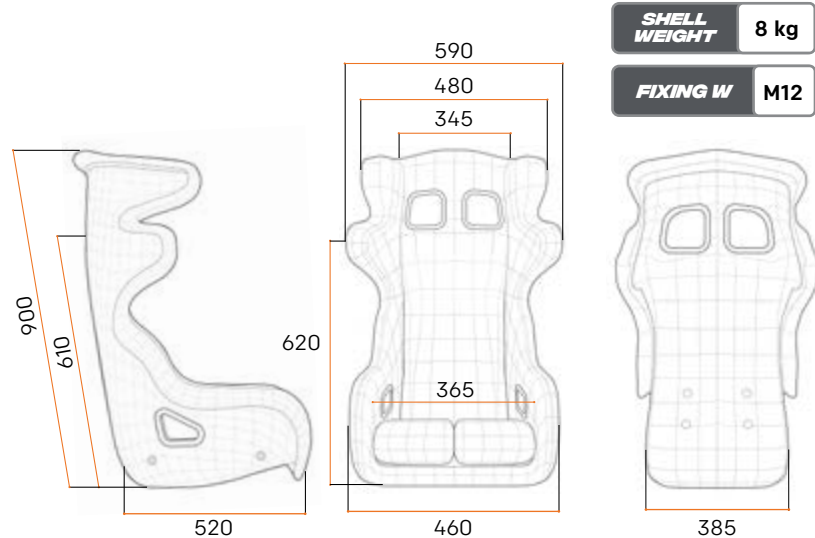

ULTRALIGHT CARBON FIBER



3D FABRIC UPHOLSTERING

# HTE ONE LITE W

HAO-0827-A01 ON REQUEST

Same features as HAO-0807-A01. 30mm WIDER THAN HTE ONE LITE

CARBON FIBER SHELL WIDE VERSION.

**SHELL WEIGHT** 8.3 kg

**FIXING W** M12



FIA 8862 - 2009



MANUFACTURER: OMP  
MODEL: HTE ONE LITE  
HOM. NO: AS.084.19  
FIA STANDARD: FIA 8862-2009

FIA 8862 - 2009



MANUFACTURER: OMP  
MODEL: HTE ONE LITE W  
HOM. NO: AS.096.21  
FIA STANDARD: FIA 8862-2009

# HTE ONE E2

HA0-0825-A01 € 6.450,00 (D)

### SAFETY STANDARDS COMPARABLE TO FORMULA 1

- Exclusive technology for maximum resistance and lightness
- Custom upholstery available on demand
- Use of supports homologated with Technical List n°40 is compulsory
- Multiple-time winner



EXTRA LARGE SHOULDER HARNESS SLOTS



SPLIT LEG REMOVABLE CUSHION



ULTRALIGHT CARBON FIBER



3D FABRIC UPHOLSTERING

**FIA 8862 - 2009**



MANUFACTURER: OMP  
MODEL: HTE ONE E2  
HOM. NO: AS.093.21  
FIA STANDARD: FIA 8862-2009

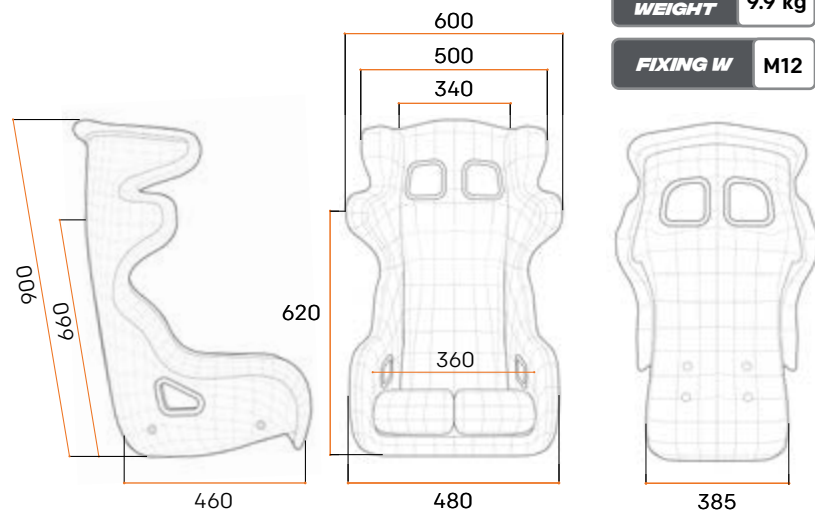

# HTE ONE E XL

HA0-0798-A01 € 7.650,00 (D)

Same features as HA0-0825-A01. LARGER THAN HTE ONE LITE E2



EXTRA LARGE SHOULDER HARNESS SLOTS



SPLIT LEG REMOVABLE CUSHION



ULTRALIGHT CARBON FIBER



3D FABRIC UPHOLSTERING

**FIA 8862 - 2009**



MANUFACTURER: OMP  
MODEL: HTE ONE XL  
HOM. NO: AS.067.17  
FIA STANDARD: FIA 8862-2009

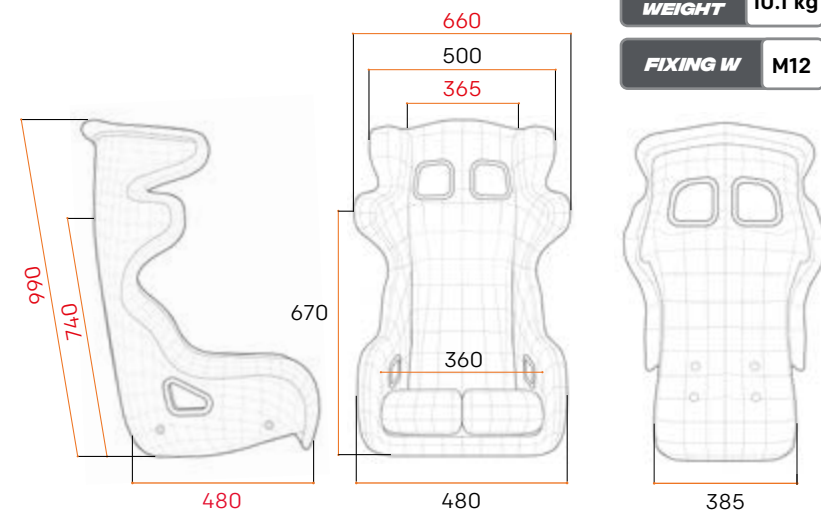

# HRC ONE LITE

HA0-0800-A01 € 9.100,00 (D)

## ULTRA LIGHTWEIGHT CARBON FIBER SEAT

- Optimized design for GT cars with reduced internal room, ensuring installation and driving comfort
- Use of supports homologated with Technical List n°40 is compulsory
- HC0-0893 HSC PATENT included

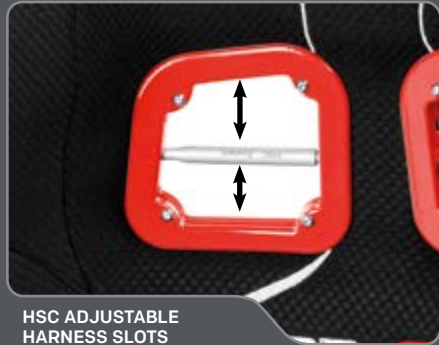

HSC ADJUSTABLE HARNESS SLOTS



SPLIT LEG CUSHION

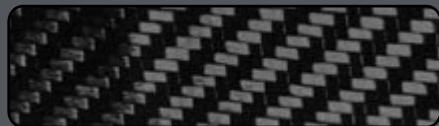

ULTRALIGHT CARBON FIBER



3D FABRIC UPHOLSTERING

**FIA 8862 - 2009**



MANUFACTURER: OMP  
MODEL: HRC ONE LITE  
HOM. NO: AS.075.19  
FIA STANDARD: FIA 8862-2009

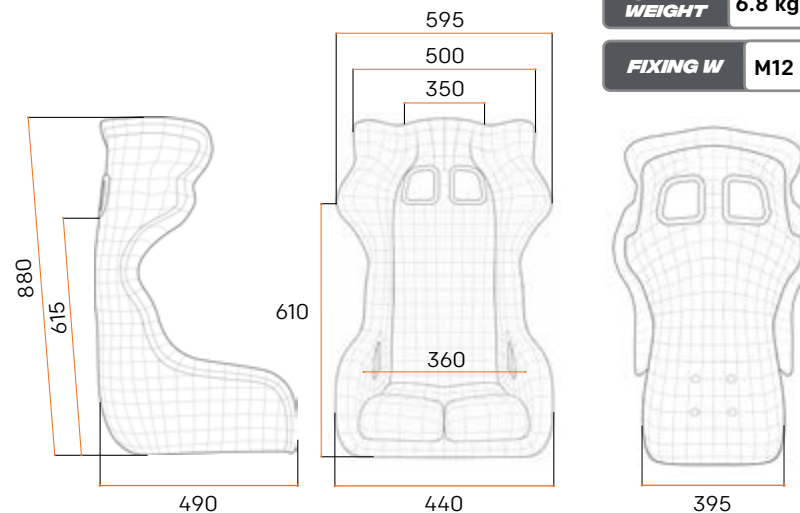

# HRC ONE LITE RC

HA0-0805-A01 € 9.400,00 (D)

## ULTRA LIGHTWEIGHT CARBON FIBER SEAT

Same features as HA0-0800-A01, but with two attachment points to the rollcage.



HRC ONE lite seat version with two attachment points to the rollcage (mandatory requirement for gt3 cars homologated after 1st january 2019)



ULTRALIGHT CARBON FIBER



3D FABRIC UPHOLSTERING

**FIA 8862 - 2009**



MANUFACTURER: OMP  
MODEL: HRC ONE LITE RC  
HOM. NO: ON REQUEST  
FIA STANDARD: FIA 8862-2009

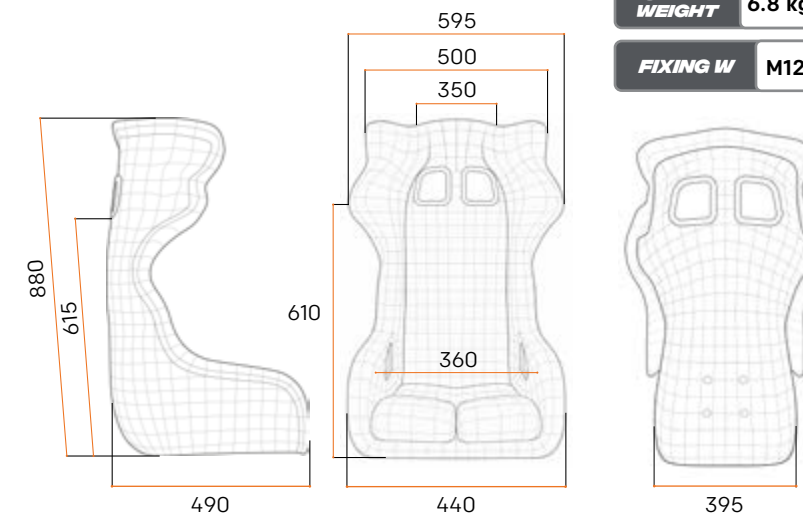

# HTC ONE

HA0-0815-A01 € 5.200,00 (D)

## CARBON FIBER SEAT WITH HIGH RESISTANT AND ULTRALIGHT SHELL

- Best lightness/price rate
- High-protection shoulder and head containment, designed to allow installation and comfortable driving position also in GT cars with reduced internal room
- The use of supports homologated with the seat in accordance with the Technical List n°40 is compulsory

Two sizes available  
**L size:** standard  
**M size:** Higher containment

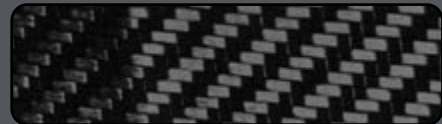

ULTRA PROTECTIVE CARBON FIBER SHELL



3D FABRIC UPHOLSTERING

**FIA 8862 - 2009**



MANUFACTURER: OMP  
 MODEL: HTC ONE  
 HOM. NO: AS.085.19  
 FIA STANDARD: FIA 8862-2009

## SEAT BRACKETS

HCO-0935-A01 € 1.600,00 (D)

SEAT BRACKETS FOR HTC ONE

**FIA 8862 - 2009**

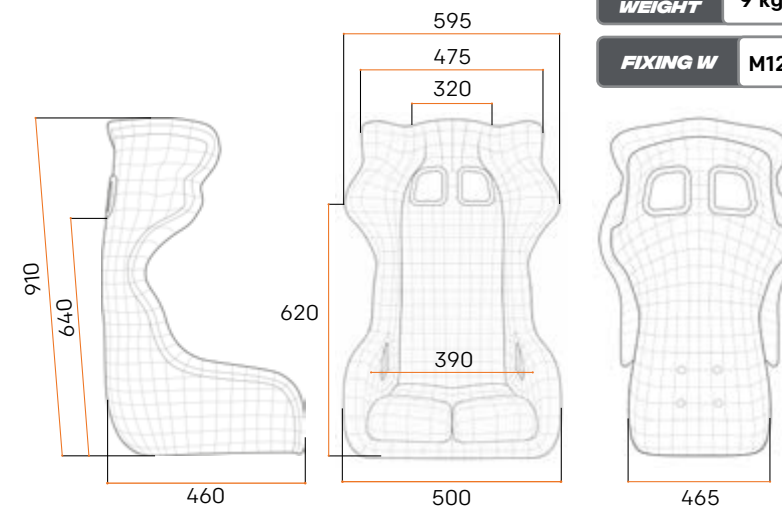

SPLIT LEG REMOVABLE CUSHION



BASE AND SHOULDERS WITH ANTI-SLIP MATERIAL



HSC PATENT COMPATIBLE

# HTC EVO CARBON

HA0-0900-A01 € 3.200,00 (D)

## LIGHTWEIGHT RACING SEAT

- High-protection shoulder and head containment
- Optimized design for GT cars with reduced internal room, ensuring installation and driving comfort
- Racing net references on side

## SEAT BRACKET NOT INCLUDED

HCO-0951-A04 for HTE EVO 2 XL (CS.019.24)

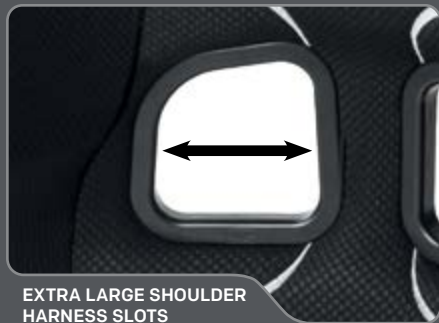

EXTRA LARGE SHOULDER HARNESS SLOTS



SHAPED LEG CUSHION



LIGHT CARBON FIBER SHELL



3D FABRIC UPHOLSTERING

FIA 8855 - 2021



MANUFACTURER: OMP  
MODEL: HTC EVO CARBON  
HOM. NO: CS.009.21  
FIA STANDARD: FIA 8855-2021

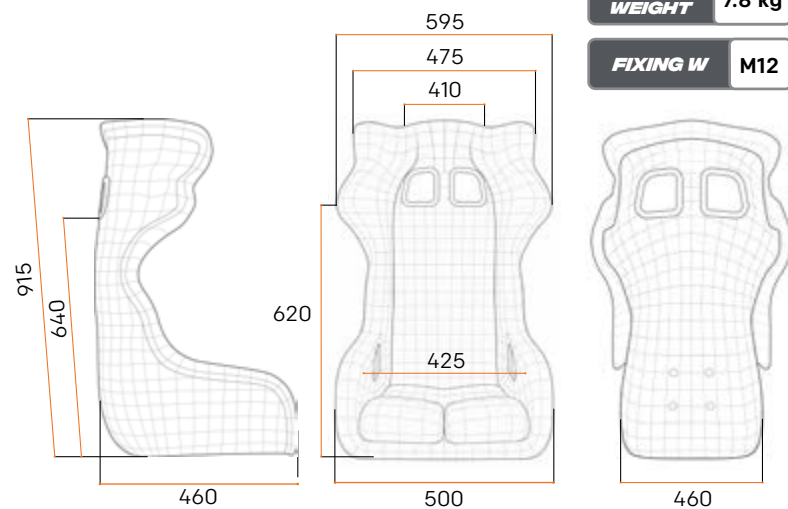

# HTC EVO

HA0-0903-A01 € 1.320,00 (L)

## GEL COATED FIBERGLASS SEAT

Same features as HA0-0900-A01, but with gel coated fiberglass shell.

## SEAT BRACKETS NOT INCLUDED

HCO-0951-A03



BASE AND SHOULDERS WITH ANTI-SLIP MATERIAL



BACK AND BASE REMOVABLE CUSHION

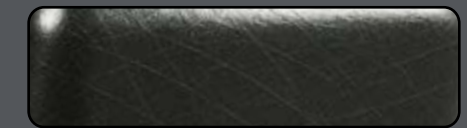

GEL COATED FIBERGLASS SHELL



3D FABRIC UPHOLSTERING

FIA 8855 - 2021



MANUFACTURER: OMP  
MODEL: HTC EVO  
HOM. NO: CS.015.23  
FIA STANDARD: FIA 8855-2021

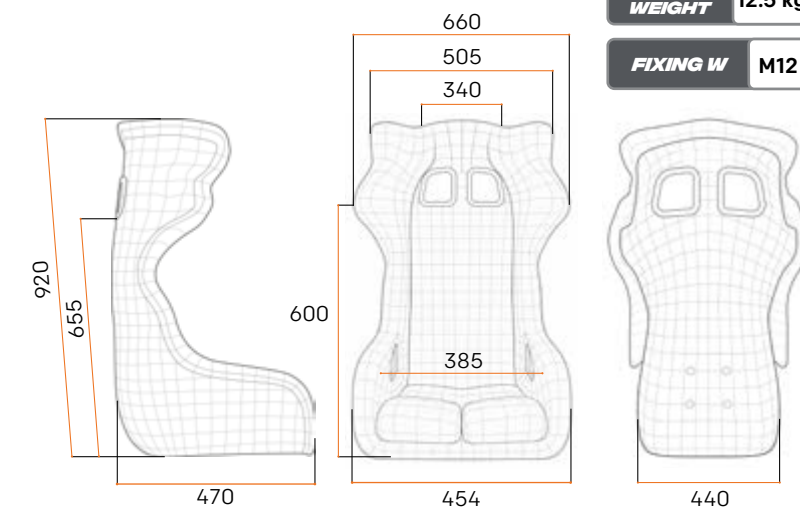

# HTE EVO 2 CARBON

HA0-0902-A01 € 3.400,00 (D)

## LIGHTWEIGHT RACING SEAT

- Innovative ultraprotective shell inspired by the OMP HTE ONE LITE multiple world champion seat
- High protection and containment, designed to accommodate various heights
- Racing net references on side
- Large shoulder harness slots

## SEAT BRACKETS NOT INCLUDED

Mandatory brackets HC0-0951-A01

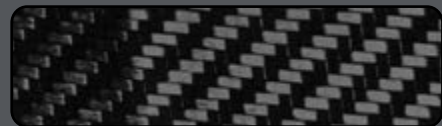

ULTRA PROTECTIVE CARBON FIBER SHELL



3D FABRIC UPHOLSTERING

FIA 8855 - 2021



MANUFACTURER: OMP  
MODEL: HTC EVO2 CARBON  
HOM. NO: CS.016.23  
FIA STANDARD: FIA 8855-2021

## SEAT BRACKETS

HC0-0951-A01 € 260,00 (C)

Seat brackets for: HTE EVO 2 CARBON

FIA 8855 - 2021

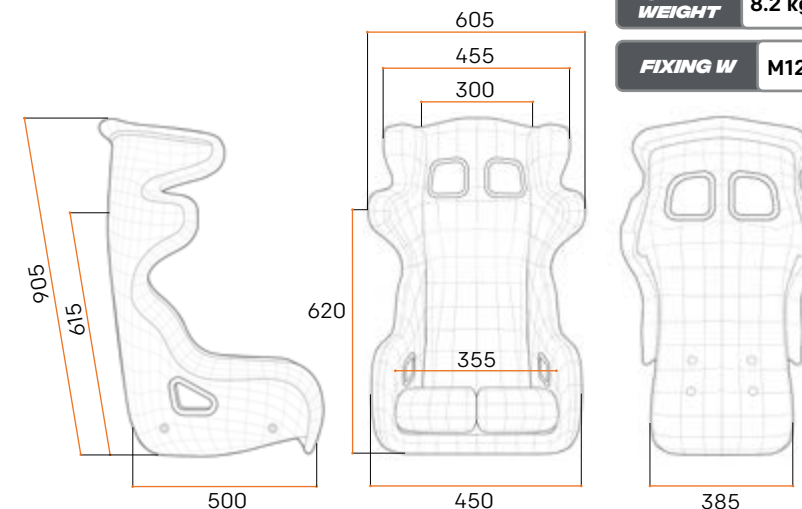

BASE AND SHOULDERS WITH ANTI-SLIP MATERIAL



EXTRA LARGE SHOULDER HARNESS SLOTS



SHAPED LEG REMOVABLE CUSHION



BACK AND BASE REMOVABLE CUSHION

# HTE EVO 2

HAO-0901-A01 € 1.420,00 (C)

## GEL COATED FIBERGLASS SEAT

- Innovative ultraproductive shell inspired by the OMP HTE ONE LITE multiple world champion seat
- High protection and containment, designed to accommodate various heights

## SEAT BRACKETS NOT INCLUDED

Mandatory brackets HCO-0951-A02



EXTRA LARGE SHOULDER HARNESS SLOTS



SHAPED LEG CUSHION



BASE AND SHOULDERS WITH ANTI-SLIP MATERIAL

FIA 8855 - 2021



MANUFACTURER: OMP  
MODEL: HTE EVO 2  
HOM. NO: CS.017.23  
FIA STANDARD: FIA 8855-2021

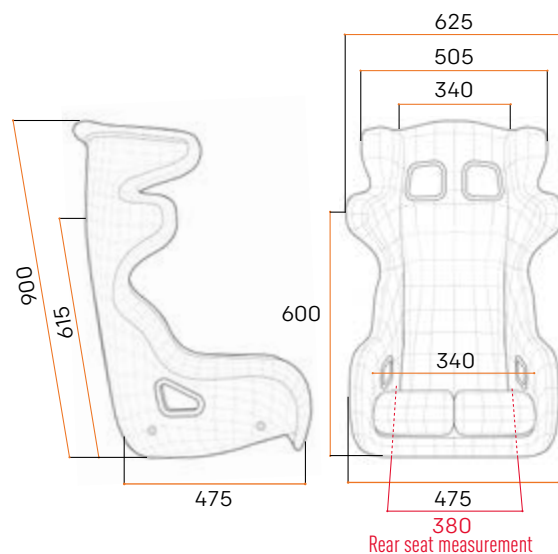

SHELL WEIGHT 12.6 kg

FIXING W M12



GEL COATED FIBERGLASS SHELL



3D FABRIC UPHOLSTERING

# HTE EVO E XL

HAO-0904-A01 € 1.500,00 (C)

**XL SHAPE:**  
Higher and wider VERSION OF HTE EVO SEAT.

SEAT BRACKETS HCO-0951-A04

WEIGHT 14.4 kg

FIXING W M12

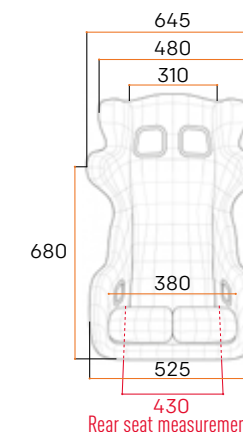
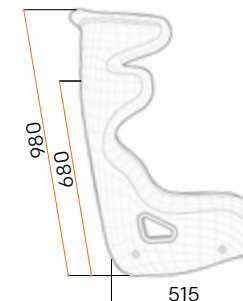

FIA 8855 - 2021



MANUFACTURER: OMP  
MODEL: HTE EVO 2 XL  
HOM. NO: AS.019.24  
FIA STANDARD: FIA 8855-2021

# HTE EVO E S

HAO-0905-A01 € 1.450,00 (C)

**S VERSION:**  
Reduced side head protection specifically designed for small cockpit car

SEAT BRACKETS HCO-0951-A05

WEIGHT 13.4 kg

FIXING W M12

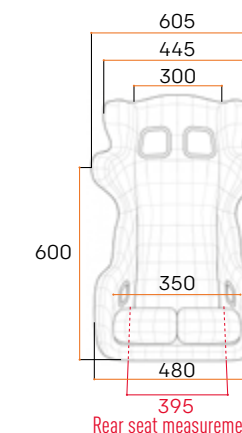
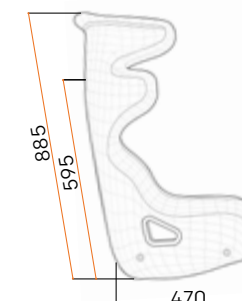

FIA 8855 - 2021



MANUFACTURER: OMP  
MODEL: HTE EVO 2 S  
HOM. NO: CS.021.24  
FIA STANDARD: FIA 8855-2021

# HGT EVO

**NEW**

HA0-0906-A01 € 1.290,00 (C)

## GEL COATED FIBERGLASS SEAT

- The HGT EVO Fiberglass Seat is designed for GT cars and offers a strong, versatile solution for a wide range of drivers
- The fiberglass shell combines durability with a controlled weight balance
- A wide internal shape ensures comfort across different body types
- Broad shoulder and head support enhance lateral stability
- Provides consistent safety and driver focus in demanding driving conditions



BACK AND BASE REMOVABLE CUSHION



SHAPED LEG CUSHION

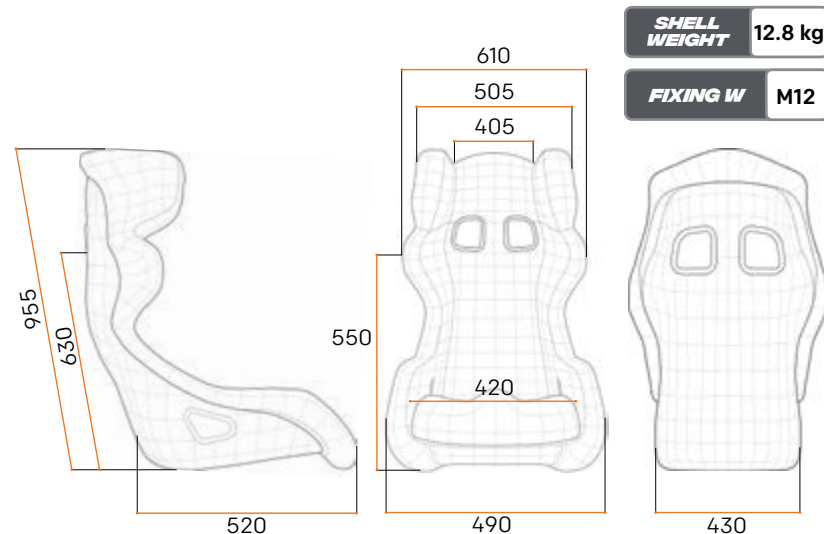

GEL COATED FIBERGLASS SHELL



3D FABRIC UPHOLSTERING

## SEAT BRACKETS

**NEW**

HCO-0954 € 140,00 (C)  
HCO-0955 € 150,00 (C)



HCO-0955

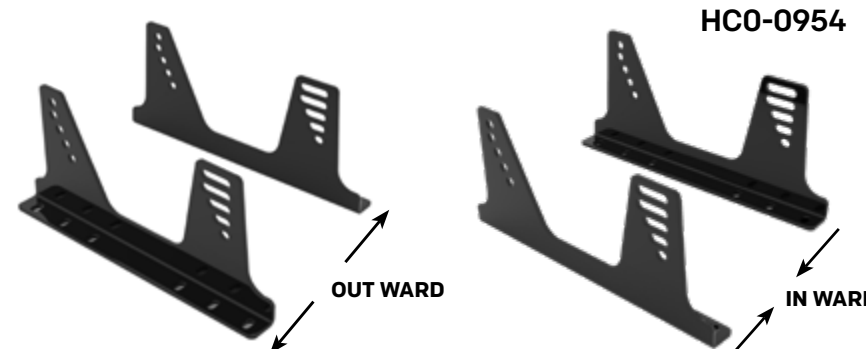

HCO-0954

### SEAT BRACKETS FOR HGT EVO

HCO\_0954 : Standard brackets  
FIA 8855-2021 homologated

HCO\_0955 : Compact brackets  
FIA 8855-2021 homologated

FIA 8855 - 2021



MANUFACTURER: OMP  
MODEL: HGT EVO  
HOM. NO: AS.028.25  
FIA STANDARD: FIA 8855-2021

# PROTOTIPO R

HA0-0745-A01 ON REQUEST

## DEAL SEAT FOR GT CARS

- Ultralight carbon shell
- Large shoulder harness slots to accommodate various heights
- High side bolsters for lateral leg support and maximum protection
- Fully upholstered in velour
- Compatible with HANS device



REMOVABLE PADDING



SPLIT LEG CUSHION



ULTRALIGHT CARBON FIBER SHELL



VELOUR TOTAL UPHOLSTERING

FIA 8855 - 1999



MANUFACTURER: OMP  
MODEL: MCC/PROTOTIPO  
HOM. NO: CS.119.04  
FIA STANDARD: FIA 8855-1999

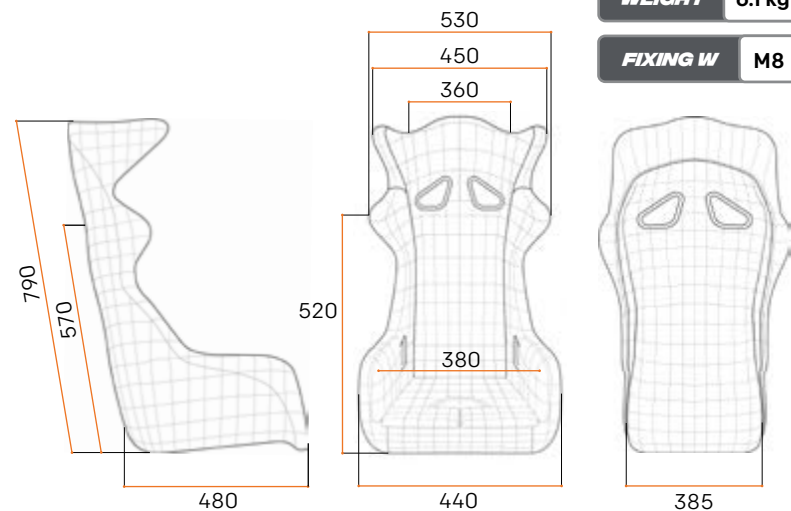

# HGT CARBON

HA0-0785-A01 € 3.100,00 (C)

## CARBON GT SEAT

- Carbon fiber seat with side head protections
- Shape designed for GT and sport cars



EXTRA LARGE SHOULDER HARNESS SLOTS



SHAPED LEG CUSHION



LIGHT CARBON FIBER SHELL



3D FABRIC UPHOLSTERING

FIA 8855 - 1999



MANUFACTURER: OMP  
MODEL: HGT  
HOM. NO: CS.28713  
FIA STANDARD: FIA 8855-1999

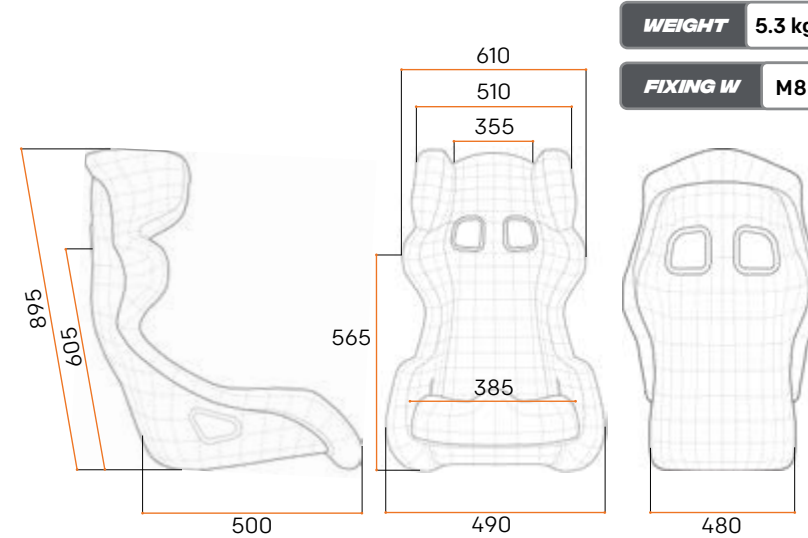

# HTE EVO CARBON

HAO-0817-A01 € 3.300,00 (D)

## LIGHTWEIGHT CARBON FIBER SEAT

- Innovative ultraproductive shell inspired by the OMP HTE ONE LITE multiple world champion seat
- High protection and containment, designed to accommodate various heights

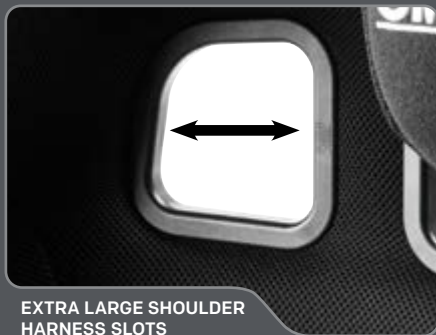

EXTRA LARGE SHOULDER HARNESS SLOTS



SHAPED LEG CUSHION



LIGHT CARBON FIBER SHELL



AIRNET

FIA 8855 - 1999



MANUFACTURER: OMP  
MODEL: HTE EVO CARBON  
HOM. NO: CS.455.20  
FIA STANDARD: FIA 8855-1999

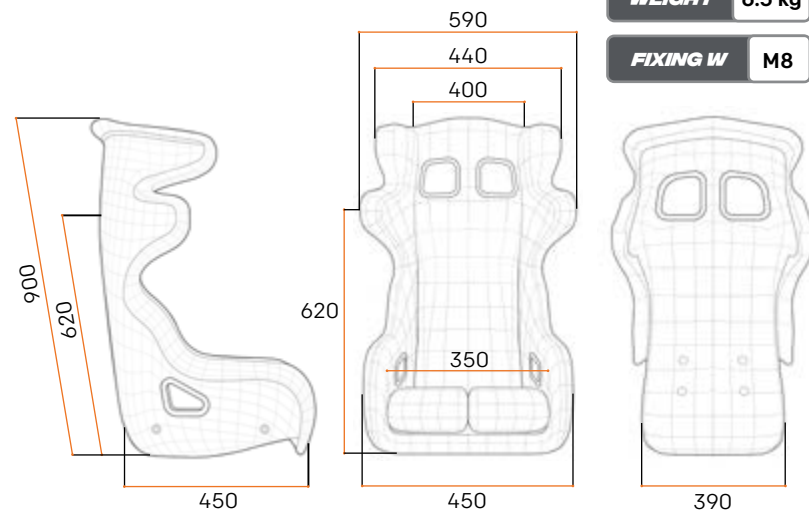

# HTE EVO

HAO-0818-A01 € 630,00 (C)

## GEL COATED FIBERGLASS SEAT

**FIBERGLASS SEAT**  
Same features as HAO-0817-A01, gel coated fiberglass



HSC PATENT COMPATIBLE



BASE AND SHOULDERS WITH ANTI-SLIP MATERIAL



GEL COATED FIBERGLASS SHELL



AIRNET

FIA 8855 - 1999



MANUFACTURER: OMP  
MODEL: HTE EVO VTR  
HOM. NO: CS.440.19  
FIA STANDARD: FIA 8855-1999

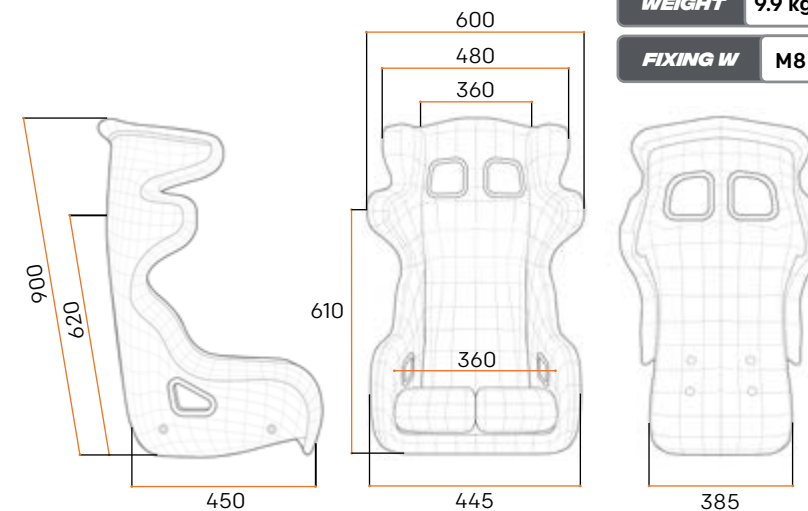

# HTE EVO OFF ROAD

HA0-0830-A01 € 840,00 (C)

## FIBERGLASS SHELL

- Same features as HA0-0818-A01
- Full gelcoat finishing
- Quick removable neoprene padding allows easy cleaning from mud and dirt
- Not FIA homologated



EXTRA LARGE SHOULDER HARNESS SLOTS



BACK, BASE REMOVABLE NEOPRENE CUSHIONS

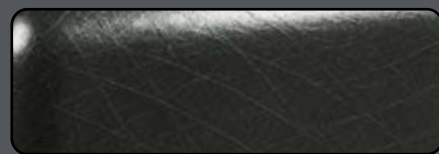

GEL COATED FIBERGLASS SHELL

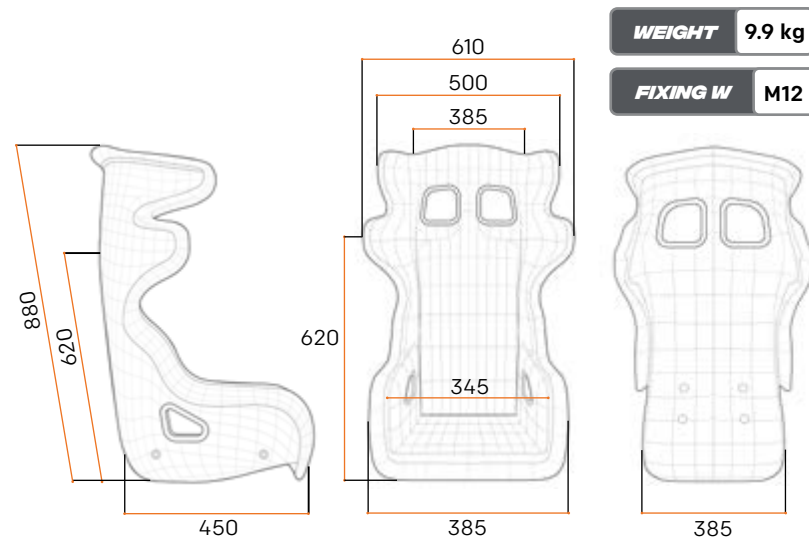

# HTE R CARBON

HAO-0768-B01 ON REQUEST

## PROFESSIONAL RACING SEAT

- Removable cushion
- Shaped safety head rest
- Shoulders and base upholstered with anti-slip material



HSC PATENT COMPATIBLE



SHAPED LEG CUSHION



EXTRA LARGE SHOULDER HARNESS SLOTS

FIA 8855 - 1999



MANUFACTURER: OMP  
MODEL: HTE CARBON  
HOM. NO: CS.146.05  
FIA STANDARD: FIA 8855-1999

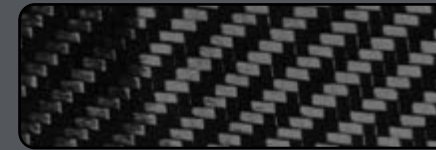
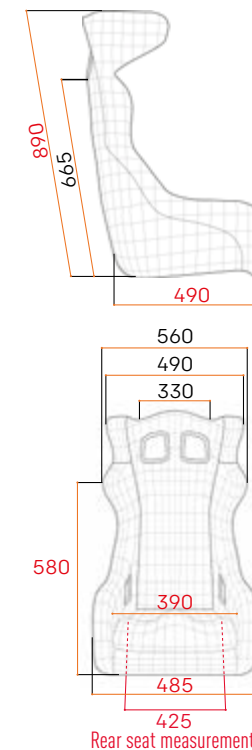
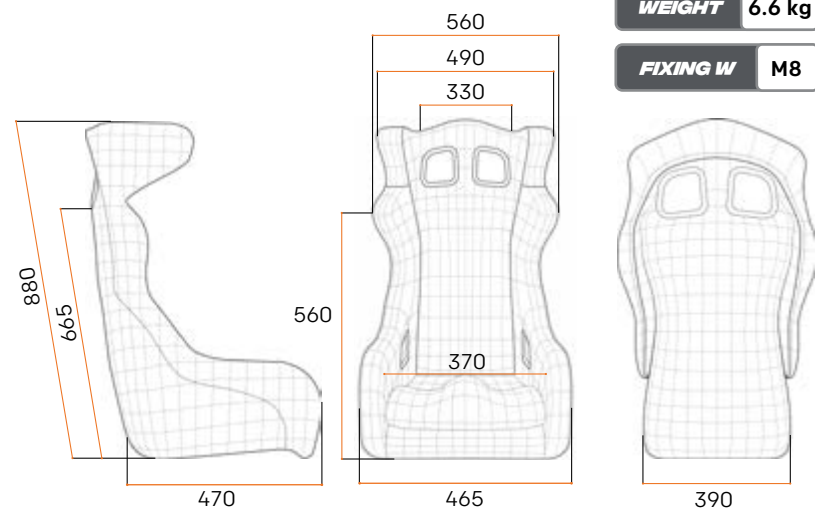

LIGHT CARBON FIBER SHELL



3D FABRIC UPHOLSTERING



AIRNET

# HTE R XL CARBON

HAO-0779-B01 € 3.350,00 (C)

XL SHAPE:  
LARGER AND HIGHER VERSION OF  
HTE R CARBON.

WEIGHT 6.8 kg

FIXING W M8

FIA 8855 - 1999



MANUFACTURER: OMP  
MODEL: HTE CARBON XL  
HOM. NO: CS.182.06  
FIA STANDARD: FIA 8855-1999

# HRC R CARBON

HA0-0788-A01 € 3.100,00 (C)

## GEL COATED FIBERGLASS SEAT

- Designed to allow installation and a comfortable driving position even in GT cars with reduced internal space
- Large shoulder harness slots to accommodate various heights



SIDE HEAD PROTECTION



EXTRA LARGE SHOULDER HARNESS SLOTS



3D FABRIC UPHOLSTERING



VELOUR



AIRNET

FIA 8855 - 1999



MANUFACTURER: OMP  
MODEL: HRC  
HOM. NO: CS.293.13  
FIA STANDARD: FIA 8855-1999



WEIGHT 5 kg

FIXING W M12

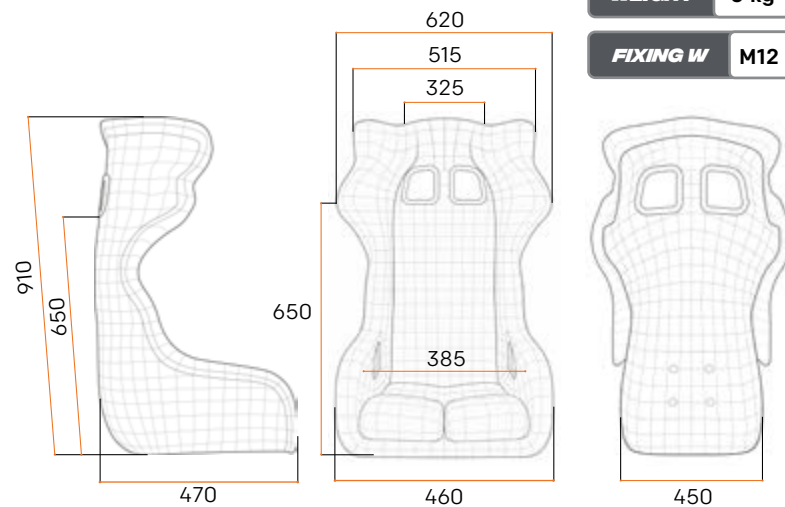

# HRC R

HA0-0793-A01 € 700,00 (C)

Same features as HA0-0788-A01, gel coated fiberglass shell.

WEIGHT 9.5 kg

FIXING W M8

FIA 8855 - 1999



MANUFACTURER: OMP  
MODEL: HRC FIBERGLASS AIR  
HOM. NO: CS.307.14  
FIA STANDARD: FIA 8855-1999

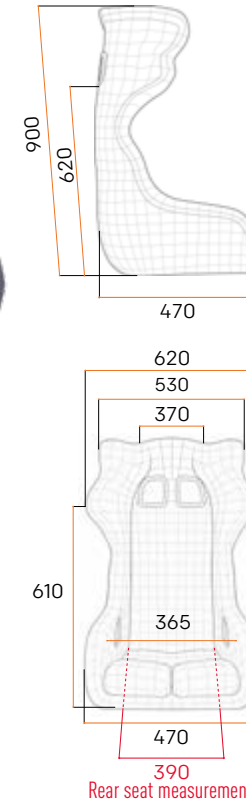

# HRC R XL

HA0-0794-A01 € 770,00 (D)

Same characteristics as HA0-0793-A01.

XL SHAPE:  
LARGER AND HIGHER VERSION OF HRC R

WEIGHT 10.3 kg

FIXING W M8

FIA 8855 - 1999



MANUFACTURER: OMP  
MODEL: HRC FIBERGLASS AIR XL  
HOM. NO: CS.313.14  
FIA STANDARD: FIA 8855-1999

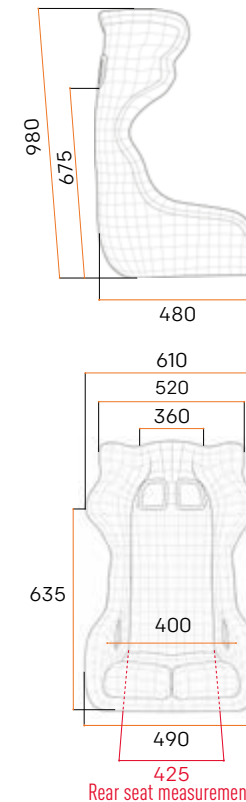

# HTE R

HAO-0772-B01 € 600,00 (C)

## GEL COATED FIBERGLASS SEAT

- Large shoulder harness slots to accommodate various heights
- Removable cushion
- Shaped safety head rest



HSC PATENT COMPATIBLE



BASE AND SHOULDERS WITH ANTI-SLIP MATERIAL



The proprietary sublimation technology "OMP Print Art" allows you to customize the seat with any design, also including photos and color blendings.  
More info at: <https://www.ompracing.com/customize-your-seats/>

FIA 8855 - 1999



MANUFACTURER: OMP  
MODEL: HTE FIBERGLASS  
HOM. NO: CS.184.06  
FIA STANDARD: FIA 8855-1999



HAO-0772-B02  
€ 930,00 (C)

WEIGHT 9.9 kg

FIXING W M8

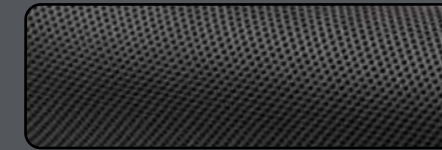
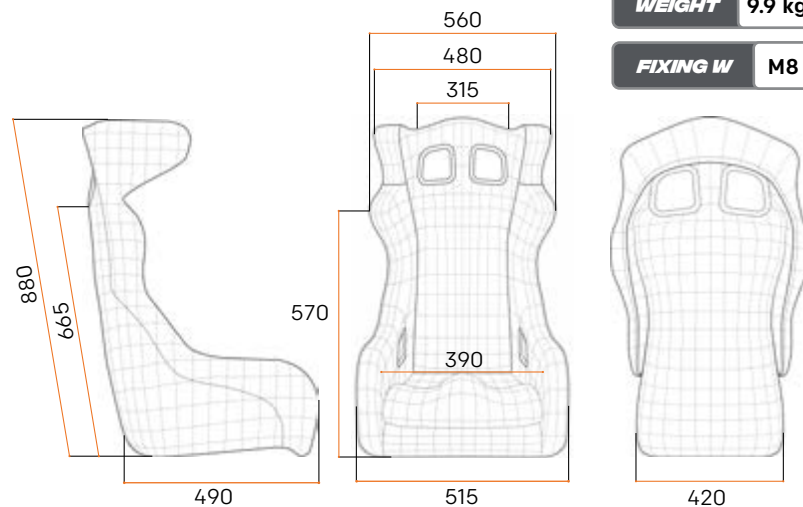

AIRNET



VELOUR

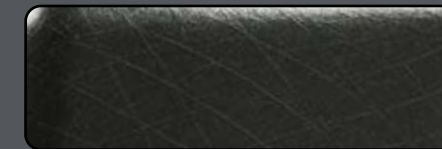

GEL COATED FIBERGLASS SHELL

# HTE R XL

HAO-0771-B01 € 700,00 (C)

Same characteristics as HAO-0772-B01.

XL VERSION:  
LARGER AND HIGHER VERSION OF HTE R

WEIGHT 11.5 kg

FIXING W M8

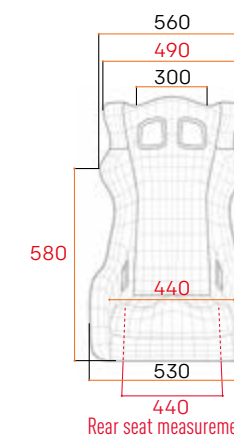
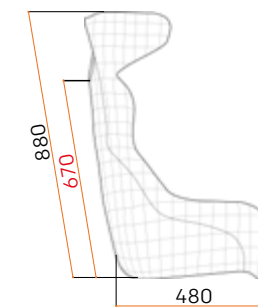

FIA 8855 - 1999



MANUFACTURER: OMP  
MODEL: HTE FIBERGLASS XL  
HOM. NO: CS.230.09  
FIA STANDARD: FIA 8855-1999

# HTE R 400

HA0-0780-B01 € 610,00 (C)

## GEL COATED FIBERGLASS SEAT

- Special version for cars with small space in the upper part
- Removable cushion
- Shaped safety head rest



Special version for cars with small space in the upper part

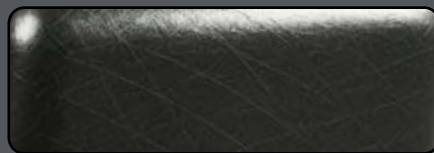

GEL COATED FIBERGLASS SHELL



AIRNET

FIA 8855 - 1999



MANUFACTURER: OMP  
MODEL: HTE 400  
HOM. NO: CS.263,14  
FIA STANDARD: FIA 8855-1999

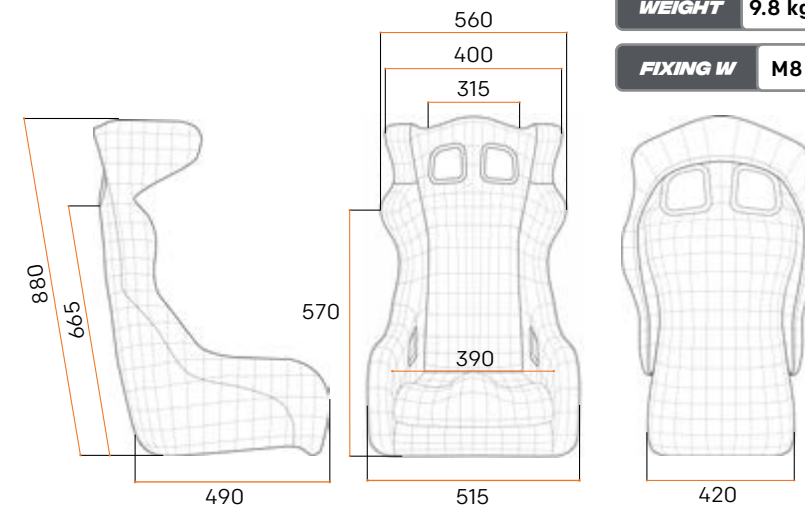

SHAPED LEG REMOVABLE CUSHION



EXTRA LARGE SHOULDER HARNESS SLOTS



HSC PATENT COMPATIBLE

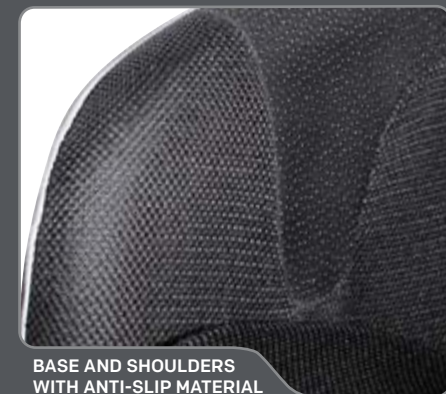

BASE AND SHOULDERS WITH ANTI-SLIP MATERIAL

# WRC R

HAO-0773-B01 € 560,00 (C)

## GEL COATED FIBERGLASS SEAT

- Removable cushion
- Shoulders and base upholstered with anti-slip material
- High profile side



HSC PATENT COMPATIBLE



SPLIT LEG CUSHION



The proprietary sublimation technology "OMP Print Art" allows you to customize the seat with any design, also including photos and color blendings.  
More info at: <https://www.ompracing.com/customize-your-seats/>

FIA 8855 - 1999



MANUFACTURER: OMP  
MODEL: WRC FIBERGLASS  
HOM. NO: CS.183.06  
FIA STANDARD: FIA 8855-1999



HAO-0773-B02  
€ 900,00 (C)

WEIGHT 8.9 kg

FIXING W M8

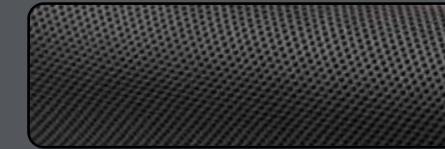
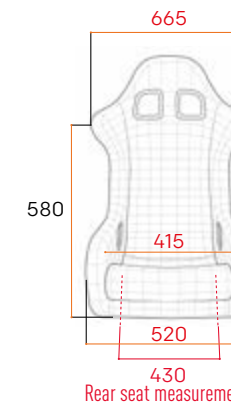
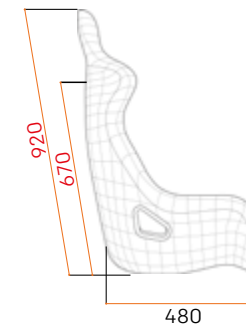
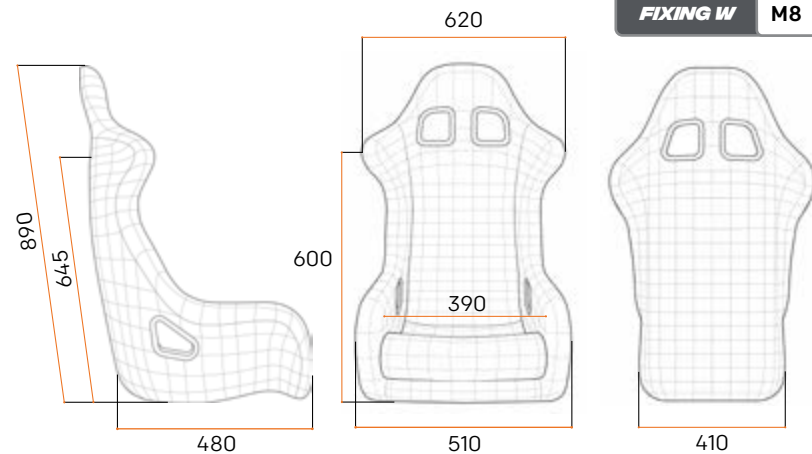

AIRNET

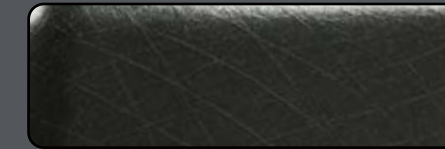

GEL COATED FIBERGLASS SHELL

# WRC R XL

HAO-0778-B01 € 640,00 (C)

Same characteristics as HAO-0773-B01.

XL VERSION:  
LARGER AND HIGHER VERSION OF WRC R

WEIGHT 10.9 kg

FIXING W M8

FIA 8855 - 1999



MANUFACTURER: OMP  
MODEL: WRC XL  
HOM. NO: CS.025.01  
FIA STANDARD: FIA 8855-1999

# ARS R

HAO-0774-B01 € 535,00 (C)

## GEL COATED FIBERGLASS SEAT

- Low profile side
- Removable cushion
- Shoulders and base upholstered with anti-slip material



HSC PATENT COMPATIBLE

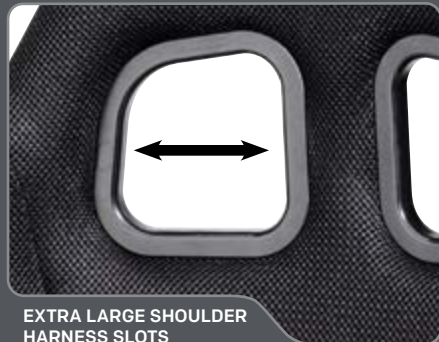

EXTRA LARGE SHOULDER HARNESS SLOTS



GEL COATED FIBERGLASS SHELL



AIRNET

FIA 8855 - 1999



MANUFACTURER: OMP  
MODEL: ARS  
HOM. NO: CS.924.98  
FIA STANDARD: FIA 8855-1999



WEIGHT 9.9 kg

FIXING W M8

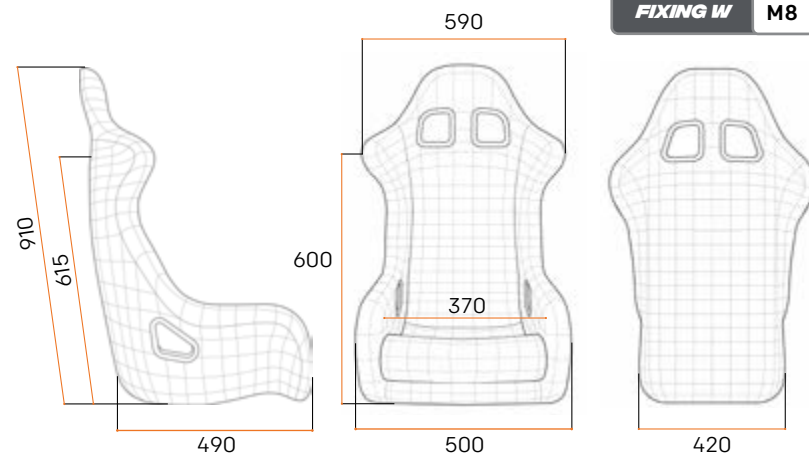

# RS PT 2

HAO-0762-B01 € 515,00 (C)

## FIBERGLASS SEAT

- Shaped safety headrest
- Removable cushion
- High side bolster



HSC PATENT COMPATIBLE



EXTRA LARGE SHOULDER HARNESS SLOTS



VELOUR

FIA 8855 - 1999



MANUFACTURER: OMP  
MODEL: RS-PT  
HOM. NO: CS.229.09  
FIA STANDARD: FIA 8855-1999



WEIGHT 10.4 kg

FIXING W M8

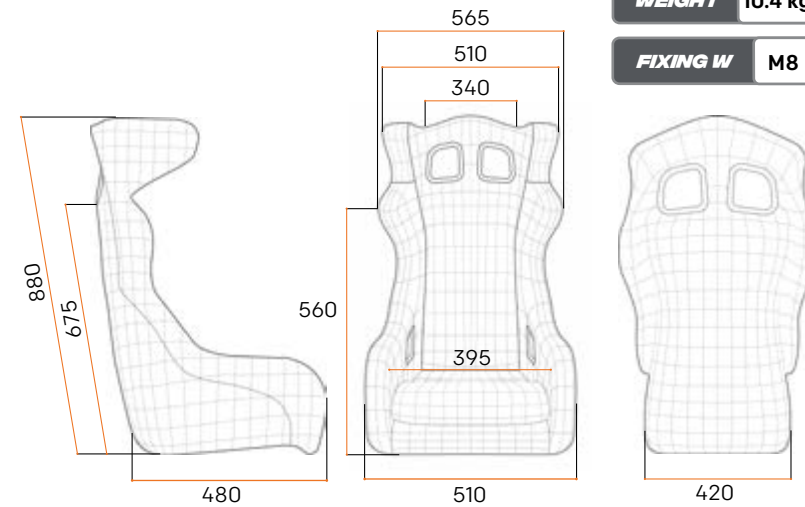

# CHAMP R

HA0-0766-B01 € 390,00 (C)

## GEL COATED FIBERGLASS SEAT

- Large shoulder harness slots to accommodate various heights
- Removable cushion
- Shaped leg cushion



HSC PATENT COMPATIBLE



BASE AND SHOULDERS WITH ANTI-SLIP MATERIAL



GEL COATED FIBERGLASS SHELL



VELOUR

FIA 8855 - 1999



MANUFACTURER: OMP  
MODEL: CHAMP  
HOM. NO: CS.826.97  
FIA STANDARD: FIA 8855-1999



WEIGHT 8.9 kg

FIXING W M8

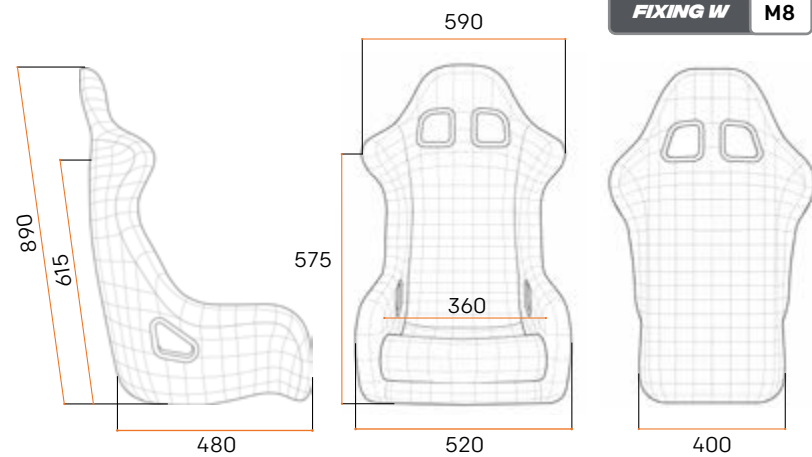

# FIRST R

HA0-0790-A01 € 360,00 (D)

## ENTRY LEVEL FIBERGLASS SEAT

- Entirely upholstered. Excellent quality/price ratio
- Removable cushion



HSC PATENT COMPATIBLE



EXTRA LARGE SHOULDER HARNESS SLOTS



UPHOLSTERED ENTIRELY IN VELOUR



WEIGHT 9.4 kg

FIXING W M8

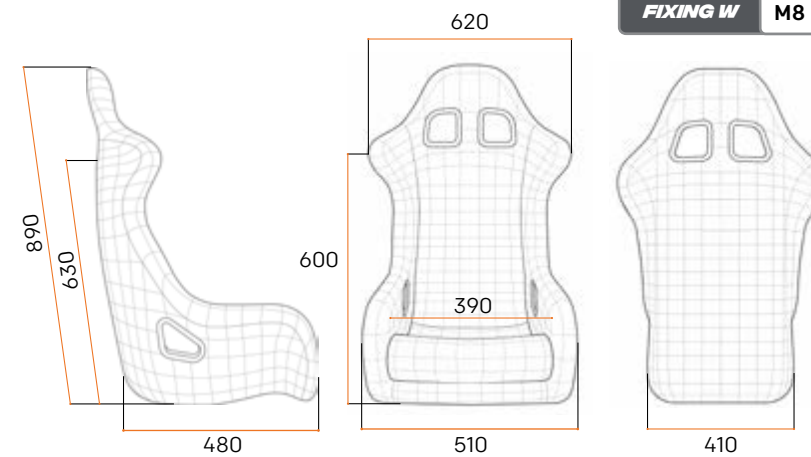

FIA 8855 - 1999



MANUFACTURER: OMP  
MODEL: FIRST-R  
HOM. NO: CS.383.06  
FIA STANDARD: FIA 8855-1999

# TRS X

HAO-0803-B01 € 270,00 (C)

## MODERN DESIGN TUBULAR SEAT

- Excellent quality/price ratio
- Medium-height side bolsters for lateral leg support and higher protection
- Removable leg rests, upholstered entirely in velour
- Optimized dimensions allow mounting also in cars with reduced inner room
- Ergonomics designed to ensure the best individual comfort and high lateral support
- HANS® compatible
- Exclusive design with modern shape and highlighted details



UPHOLSTERED ENTIRELY IN VELOUR

FIA 8855 - 1999



MANUFACTURER: OMP  
MODEL: TRS-X  
HOM. NO: CS.410.18  
FIA STANDARD: FIA 8855-1999



TUBULAR STEEL FRAME



BASE AND SHOULDERS WITH ANTI-SLIP MATERIAL



EXTRA LARGE SHOULDER HARNESS SLOTS

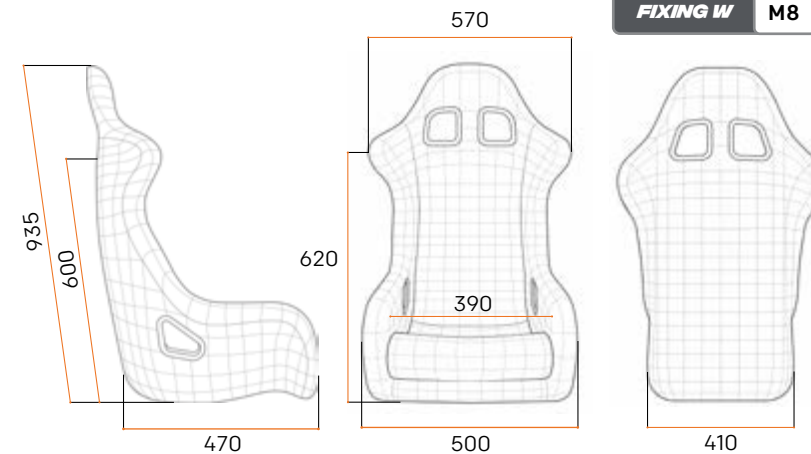

WEIGHT 10.8 kg

FIXING Y M8

FIXING W M8

# TRS E

HAO-0741-B01 € 245,00 (C)

## ENTRY LEVEL TUBULAR SEAT

- Excellent quality/price ratio
- Large shoulder harness slots to accommodate various heights
- Removable cushion
- HSC patent compatible



HAO-0741-B01-041



HAO-0741-B01-071



HAO-0741-B01-061



UPHOLSTERED ENTIRELY IN VELOUR

FIA 8855 - 1999



MANUFACTURER: OMP  
MODEL: T-RS  
HOM. NO: CS.243.10  
FIA STANDARD: FIA 8855-1999



WEIGHT 10.3 kg

FIXING Y M8

FIXING W M8

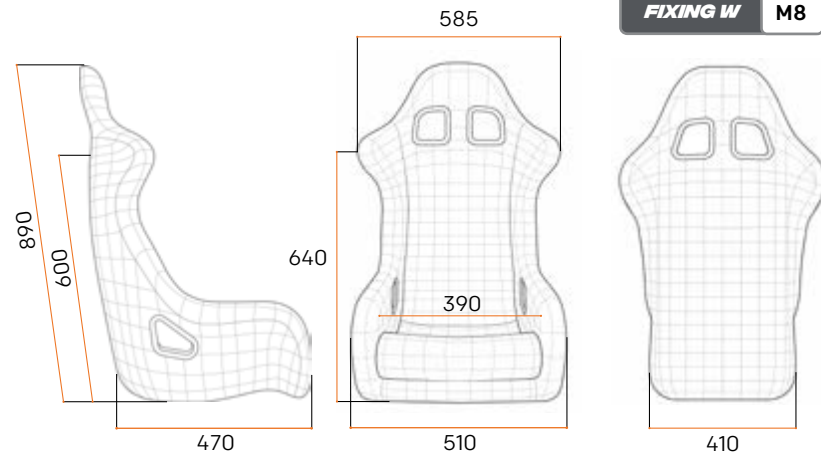

# TRS E SKY

HAO-0760-B01 € 305,00 (C)

Same features as HAO-0741-B01 but in vinyl.

WEIGHT 10.8 kg

FIXING Y M8

FIXING W M8

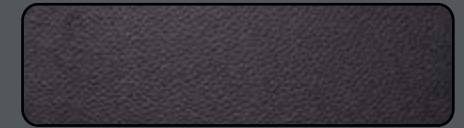

VINYL

FIA 8855 - 1999



MANUFACTURER: OMP  
MODEL: T-RS  
HOM. NO: CS.243.10  
FIA STANDARD: FIA 8855-1999

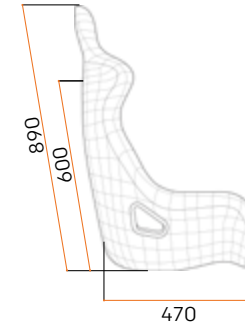

# TRS E XL

HAO-0781-B01 € 285,00 (C)

Same features as HAO-0741-B01. (only W side fixing points).

XL VERSION:  
LARGER AND HIGHER VERSION OF TRS E

WEIGHT 12.3 kg

FIXING W M8

FIA 8855 - 1999



MANUFACTURER: OMP  
MODEL: TRS XL  
HOM. NO: CS.271.12  
FIA STANDARD: FIA 8855-1999

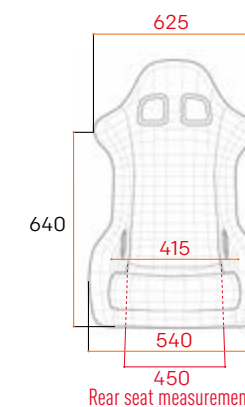
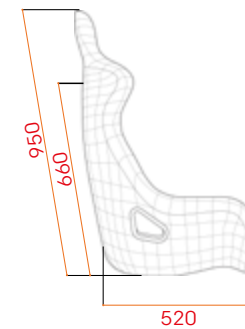

# RT LEATHER CARBON

HAO-0831-A01 € 1.630,00 (C)

## HIGH END RACING SEAT

- Bucket racing seat in fiberglass, FIA 8855-1999 homologated
- Ergonomic shape with removable soft padded inserts upholstered in fine material, ensuring comfort in every condition from tuning to racing
- Innovative shoulder harness slot design.
- Wide leg cushion to improve driving comfort
- Lower sides to facilitate cockpit access



NEW SHOULDER HARNESS SLOTS

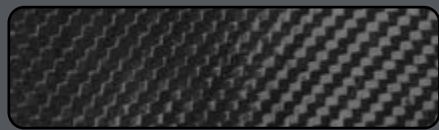
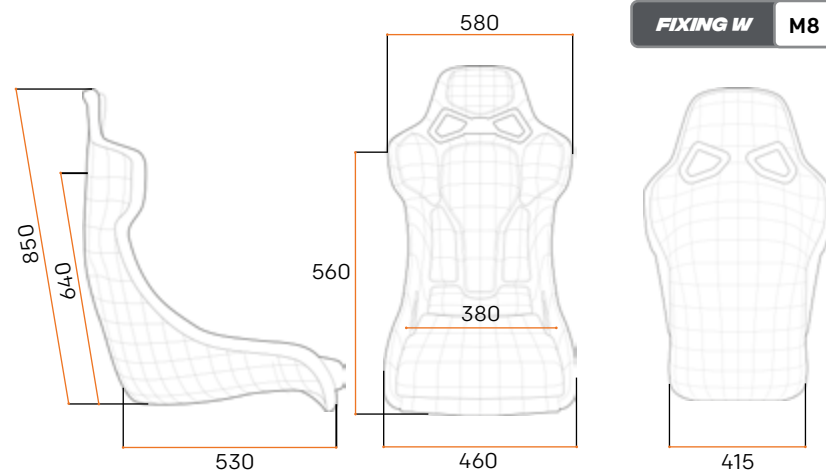

CARBON FIBER SHELL



LEATHER

FIA 8855 - 1999



MANUFACTURER: OMP  
MODEL: CW0093  
HOM. NO: CS.505.22  
FIA STANDARD: FIA 8855-1999

# RT CARBON

HAO-0831-A02 € 1.630,00 (C)

Same features as HAO-0831-A01. Upholstering in leather with suede microfiber fabric inserts.

**WEIGHT** 5.2 kg

**FIXING W** M8

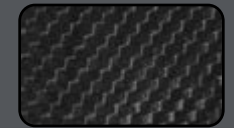

CARBON FIBER SHELL

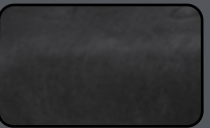

SUEDE MICROFIBER

FIA 8855 - 1999



MANUFACTURER: OMP  
MODEL: CW0093  
HOM. NO: CS.505.22  
FIA STANDARD: FIA 8855-1999

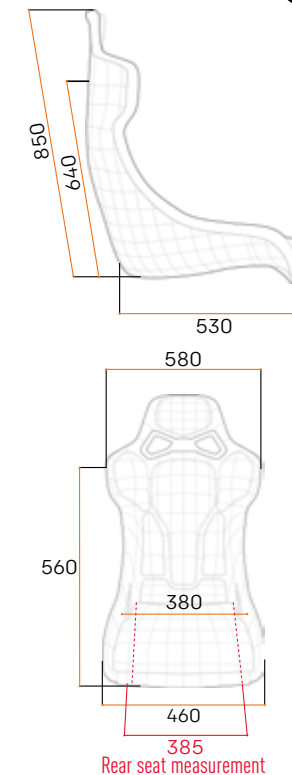

# RT

HAO-0832-A01 € 770,00 (C)

Same features as HAO-0831-A01 but with gel coated fiberglass shell.

**WEIGHT** 6.7 kg

**FIXING M8 W**



GEL COATED FIBERGLASS SHELL



LEATHER

FIA 8855 - 1999



MANUFACTURER: OMP  
MODEL: CW0092  
HOM. NO: CS.501.22  
FIA STANDARD: FIA 8855-1999

# RTS RECLINING SEAT

HA0-0833-A01 € 450,00 (A)

## HIGH END RECLINING SEAT

- Reclining comfort seat upholstered in fine leather and soft suede
- Steel frame for maximum strength and durability
- Innovative shoulder harness slot design
- High-precision backrest adjustment, similar to OEM car seats
- High-containment foam for enhanced driving feel
- Upholstering with 3D-effect stitching.
- Sliding brackets included

SUEDE MICROFIBER

LEATHER MICROFIBER

## SEAT BRACKETS

HA0-0833-A01 INCLUDED

SLIDING BRACKETS **INCLUDED**

FOR RTS RECLINING SEAT ONLY



NEW SHOULDER HARNESS SLOTS



RECLINING SYSTEM



**WEIGHT** 15.8 kg

**FIXING Y** M8

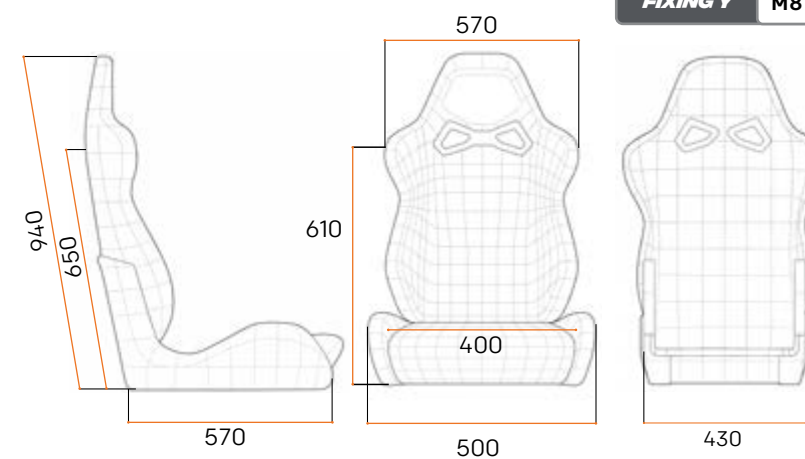

# RACING SEAT TABLE

THE FOLLOWING MEASUREMENTS ARE GIVEN AS A GUIDE. ACTUAL MEASUREMENTS MAY VARY TO ACCOMODATE PRODUCTION. Seat fitting type: according to FIA regulations the seat must be fixed to the brackets by means of at least four bolts M8 class 8.8. The diagram shows the distances between the fixing points in mm.

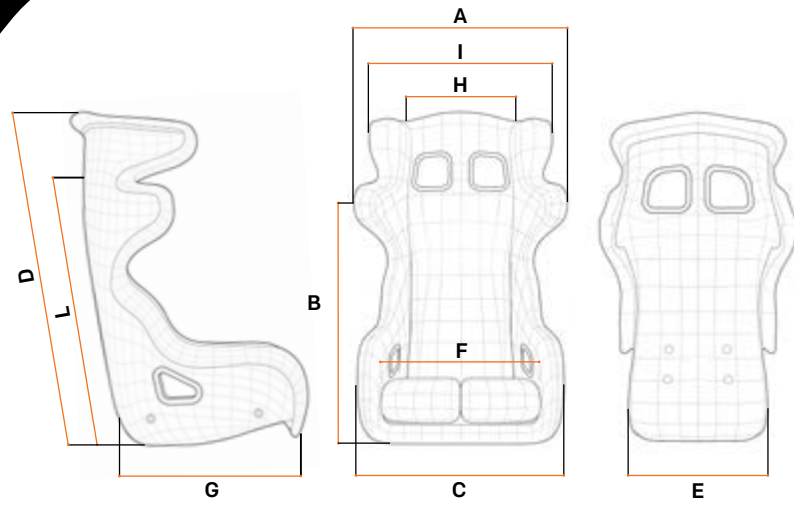

Bottom fixing points of the sliding guide. **TYPE W:** inner side int. 289 mm  
**TYPE Y:** bottom 345x270 mm

## LEGEND

- A** external max width at shoulders
- B** seat bottom to mid shoulders
- C** seat bottom max external width
- D** total height of seat back
- E** external max width at seat fixing inserts
- F** seat inner width (belt holes area)
- G** bottom length
- H** internal width between side headprotections
- I** external width between side headprotections
- L** height from the bottom to the harness slot
- W** = side fixing **Y** = bottom fixing

### \*note

For **FIA 8855-1999** seats, the weight refers to the complete seat (tolerance of 10%).  
For **FIA 8862-2009 / FIA 8855-2021** seats, the weight refers to the shell (tolerance of 10%).

## FIA 8862 - 2009 CARBON FIBER SHELL

|   | A   | B   | C   | D   | E   | F   | G   | H   | I   | L   | SLOTS | KG*  | FIXING |
|---|-----|-----|-----|-----|-----|-----|-----|-----|-----|-----|-------|------|--------|
| <b>HTE-ONE ULTRA LITE</b><br>HAO-0829-A01 | 590 | 610 | 445 | 880 | 395 | 360 | 490 | 350 | 475 | 610 | 5     | 5.9  | W      |
| <b>HTE-ONE LITE</b><br>HAO-0807-A01       | 590 | 620 | 460 | 900 | 385 | 365 | 520 | 345 | 480 | 610 | 5     | 8.3  | W      |
| <b>HTE-ONE LITE W</b><br>HAO-0827-A01     | 590 | 620 | 490 | 900 | 415 | 395 | 520 | 345 | 480 | 610 | 5     | 8    | W      |
| <b>HTE-ONE E 2</b><br>HAO-0825            | 600 | 620 | 480 | 900 | 385 | 360 | 460 | 340 | 500 | 660 | 5     | 9.9  | W      |
| <b>HTE-ONE E XL</b><br>HAO-0798-A01       | 660 | 670 | 480 | 990 | 385 | 360 | 480 | 365 | 500 | 740 | 5     | 10.1 | W      |
| <b>HRC-ONE LITE</b><br>HAO-0800-A01       | 595 | 610 | 440 | 880 | 395 | 360 | 490 | 350 | 500 | 615 | 5     | 6.8  | W      |
| <b>HRC-ONE LITE RC</b><br>HAO-0805-A01    | 595 | 610 | 440 | 880 | 395 | 360 | 490 | 350 | 500 | 615 | 5     | 6.8  | W      |
| <b>HTC-ONE</b><br>HAO-0815-A01            | 595 | 620 | 500 | 910 | 465 | 390 | 460 | 320 | 475 | 640 | 5     | 9    | W      |

## FIA 8855 - 2021 CARBON AND FIBERGLASS SHELL

|                                       | A   | B   | C   | D   | E   | F   | G   | H   | I   | L   | SLOTS | KG*  | FIXING |
|---------------------------------------|-----|-----|-----|-----|-----|-----|-----|-----|-----|-----|-------|------|--------|
| <b>HTC-EVO CARB</b><br>HAO-0900-A01   | 595 | 620 | 500 | 915 | 460 | 425 | 460 | 410 | 475 | 640 | 5     | 7.8  | W      |
| <b>HTC-EVO</b><br>HAO-0903-A01        | 660 | 600 | 454 | 920 | 440 | 385 | 470 | 340 | 505 | 655 | 5     | 12.5 | W      |
| <b>HTE-EVO 2 CARB</b><br>HAO-0902-A01 | 605 | 620 | 450 | 905 | 385 | 355 | 475 | 340 | 505 | 615 | 5     | 8.2  | W      |
| <b>HTE-EVO 2</b><br>HAO-0901-A01      | 625 | 600 | 475 | 900 | 380 | 340 | 500 | 300 | 455 | 615 | 5     | 12.6 | W      |
| <b>HTE-EVO 2 XL</b><br>HAO-0904-A01   | 645 | 680 | 525 | 980 | 430 | 380 | 515 | 310 | 480 | 680 | 5     | 14.4 | W      |
| <b>HTE-EVO 2 S</b><br>HAO-0905-A01    | 605 | 600 | 480 | 885 | 395 | 350 | 470 | 300 | 445 | 595 | 5     | 13.4 | W      |
| <b>HGT-EVO</b><br>HAO-0906-A01        | 610 | 550 | 490 | 955 | 430 | 420 | 520 | 405 | 505 | 630 | 5     | 12.8 | W      |

## FIA 8855 - 1999 CARBON FIBER SHELL

|                                      | A   | B   | C   | D   | E   | F   | G   | H   | I   | L   | SLOTS | KG* | FIXING |
|--------------------------------------|-----|-----|-----|-----|-----|-----|-----|-----|-----|-----|-------|-----|--------|
| <b>PROTOTIPO R</b><br>HAO-0745-A01   | 530 | 520 | 440 | 790 | 385 | 380 | 480 | 360 | 450 | 570 | 5     | 6.1 | W      |
| <b>HGT CARB</b><br>HAO-0785-A01      | 610 | 565 | 490 | 895 | 480 | 385 | 500 | 355 | 510 | 605 | 5     | 5.3 | W      |
| <b>HTE-EVO CARB</b><br>HAO-0817-A01  | 590 | 620 | 450 | 900 | 390 | 350 | 450 | 400 | 440 | 620 | 5     | 6.5 | W      |
| <b>HRC-R CARB</b><br>HAO-0788-A01    | 620 | 650 | 460 | 910 | 450 | 385 | 470 | 325 | 515 | 650 | 5     | 5   | W      |
| <b>HTE-R CARB</b><br>HAO-0768-B01    | 560 | 560 | 465 | 880 | 390 | 370 | 470 | 330 | 490 | 665 | 5     | 6.6 | W      |
| <b>HTE-R CARB XL</b><br>HAO-0779-B01 | 560 | 580 | 485 | 890 | 425 | 390 | 490 | 330 | 490 | 665 | 5     | 6.8 | W      |
| <b>RT-CARB</b><br>HAO-0831-A01       | 570 | 565 | 415 | 850 | 415 | 375 | 520 | /   | /   | 630 | 5     | 5.2 | w      |

|  |   |   |   |     |     |     |     |     |     |     |     |     |     |   |     |   |
|--|---|---|---|-----|-----|-----|-----|-----|-----|-----|-----|-----|-----|---|-----|---|
| <b>HTE-EVO OFFROAD</b><br>HAO-0833-A01 | ? | / | / | 610 | 620 | 385 | 880 | 385 | 345 | 450 | 385 | 500 | 620 | 5 | 9.9 | W |
|--|---|---|---|-----|-----|-----|-----|-----|-----|-----|-----|-----|-----|---|-----|---|

NOT FIA HOMOLOGATED

## FIA 8855 - 1999 FIBERGLASS SHELL

|                                  | A   | B   | C   | D   | E   | F   | G   | H   | I   | L   | SLOTS | KG*  | FIXING |
|----------------------------------|-----|-----|-----|-----|-----|-----|-----|-----|-----|-----|-------|------|--------|
| <b>HTE-EVO</b><br>HAO-0818-A01   | 600 | 610 | 445 | 900 | 385 | 360 | 450 | 360 | 480 | 620 | 5     | 9.9  | W      |
| <b>HRC-R</b><br>HAO-0793-A01     | 620 | 610 | 470 | 900 | 390 | 365 | 470 | 370 | 530 | 620 | 5     | 9.5  | W      |
| <b>HRC-R XL</b><br>HAO-0794-A01  | 610 | 635 | 490 | 980 | 425 | 400 | 480 | 360 | 520 | 675 | 5     | 10.3 | W      |
| <b>HTE-R</b><br>HAO-0772-B01     | 560 | 570 | 515 | 880 | 420 | 390 | 490 | 315 | 480 | 665 | 5     | 9.9  | W      |
| <b>HTE-R XL</b><br>HAO-0771-B01  | 560 | 580 | 530 | 880 | 440 | 440 | 480 | 300 | 490 | 670 | 5     | 11.5 | W      |
| <b>HTE-R 400</b><br>HAO-0780-B01 | 560 | 570 | 515 | 880 | 420 | 390 | 490 | 315 | 400 | 665 | 5     | 9.8  | W      |
| <b>WRC-R</b><br>HAO-0773-B01     | 620 | 600 | 510 | 890 | 410 | 390 | 480 | /   | /   | 645 | 5     | 8.9  | W      |
| <b>WRC-R XL</b><br>HAO-0778-B01  | 665 | 580 | 520 | 920 | 430 | 415 | 480 | /   | /   | 670 | 5     | 10.9 | W      |
| <b>ARS-R</b><br>HAO-0774-B01     | 590 | 600 | 500 | 910 | 420 | 370 | 490 | /   | /   | 615 | 5     | 9.9  | W      |
| <b>RS-PT 2</b><br>HAO-0762-B01   | 565 | 560 | 510 | 880 | 420 | 395 | 480 | 340 | 510 | 675 | 5     | 10.4 | W      |
| <b>CHAMP-R</b><br>HAO-0766-B01   | 590 | 575 | 520 | 890 | 400 | 360 | 480 | /   | /   | 615 | 5     | 8.9  | W      |
| <b>FIRST-R</b><br>HAO-0790-A01   | 620 | 600 | 510 | 890 | 410 | 390 | 480 | /   | /   | 630 | 5     | 9.4  | W      |
| <b>RT</b><br>HAO-0832-A01        | 580 | 560 | 460 | 850 | 415 | 380 | 530 | /   | /   | 640 | 5     | 6.7  | W      |

|                            |   |   |   |     |     |     |     |     |     |     |   |   |     |   |      |   |
|----------------------------|---|---|---|-----|-----|-----|-----|-----|-----|-----|---|---|-----|---|------|---|
| <b>RTS</b><br>HAO-0833-A01 | / | / | / | 570 | 610 | 500 | 940 | 430 | 400 | 570 | / | / | 650 | 5 | 15.8 | W |
|----------------------------|---|---|---|-----|-----|-----|-----|-----|-----|-----|---|---|-----|---|------|---|

NOT FIA HOMOLOGATION

## FIA 8855 - 1999 TUBULAR STEEL FRAME

|                                  | A   | B   | C   | D   | E   | F   | G   | H | I | L   | SLOTS | KG*  | FIXING |
|----------------------------------|-----|-----|-----|-----|-----|-----|-----|---|---|-----|-------|------|--------|
| <b>TRS-X</b><br>HAO-803-B01      | 570 | 620 | 500 | 935 | 410 | 390 | 470 | / | / | 600 | 5     | 10.8 | WY     |
| <b>TRS-E</b><br>HAO-0741-B01     | 585 | 640 | 510 | 890 | 410 | 390 | 470 | / | / | 600 | 5     | 10.3 | WY     |
| <b>TRS-E SKY</b><br>HAO-0760-B01 | 585 | 640 | 510 | 890 | 410 | 390 | 470 | / | / | 600 | 5     | 10.8 | WY     |
| <b>TRS-E XL</b><br>HAO-0781-B01  | 625 | 640 | 540 | 950 | 450 | 415 | 520 | / | / | 660 | 5     | 12.3 | W      |

# CLASSIC

HAO-0737-B01 € 345,00 (A)

## '70S REVIVAL VINTAGE SEAT

Upholstered in faux leather and velvet.  
Tubular steel frame M8 lower fixing points  
345x270 mm Y

- adjustable velvet headrest
- raised backrest and velvet seat
- faux leather sides

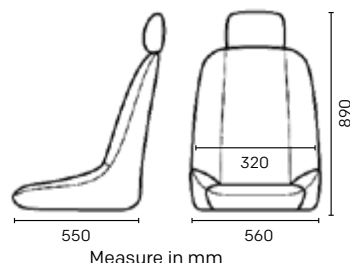

# BRANDS HATCH

HAO-0757-A01 € 380,00 (A)

## VINTAGE '60S STYLE SEAT

Upholstered in faux leather and velvet.  
Tubular steel frame M8 lower fixing points  
345x270 mm Y

- adjustable velvet headrest
- raised backrest and velvet seat
- faux leather sides

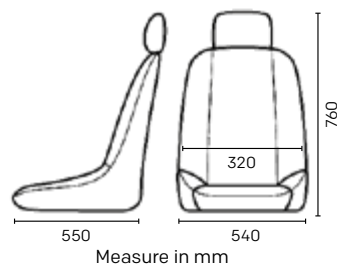

# SILVERSTONE

HAO-0756-A01 € 335,00 (A)

## VINTAGE SEAT SPECIFIC FOR OPEN CARS

Upholstered in faux leather. Back with horizontal quilting.  
Tubular steel frame M8 lower fixing points  
345x270 mm Y

- faux leather sides

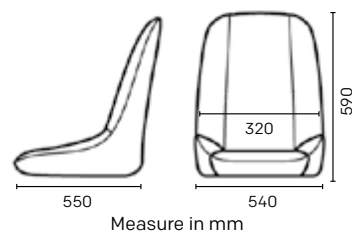

## SPARE COLORED HARNESS SHOULDER KIT

HCO-0930 € 27,50 (C)

Kit of spare harness slots adaptable on most of OMP racing seat. Several colors available: black like the original ones, white, red, fluo green, fluo orange, fluo yellow.



## LATERAL PAIR CUSHIONS

HBO-0701 € 145,00 (C)

For HRC seats. Sizes: S, M  
Velour material.



## LEG CUSHIONS

HBO-0698 € 67,00 (C)

Shaped leg support cushions. Airnet material.



## LEG CUSHIONS

HBO-0700 € 54,50 (C)

2 pieces flat leg support cushions. Airnet material.



## LEG CUSHIONS

HBO-0702 € 79,00 (C)

Thicker seat cushions for HRC seat. Antislip velvet.



## HSC PATENT

HCO-0893 € 236,00 (C)

Adjustable aluminium cover for 3 safety belt's positions setting.  
**PATENTED**



# RACING SEAT ACCESSORIES

## SPARE COLORED HARNESS LATERAL KIT

HCO-0931 € 27,50 (C)

Kit of spare harness slots adaptable on most of OMP racing seats. Several colors available: black like the original ones, white, red, fluo green, fluo orange, fluo yellow.

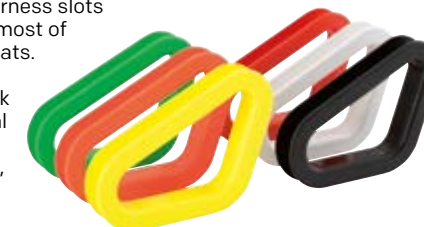

## SEAT CUSHIONS

HBO-0692 € 31,00 (C)

A Back support cushion, small  
Dimensions: 240x110mm

HBO-0662 € 56,00 (C)

B Lumbar support cushion, medium  
Dimensions: 300x175mm

HBO-0695 € 59,00 (C)

C Seat cushion  
Dimensions: 330x260mm

HBO-0693 € 57,00 (C)

D Leg support cushion  
Dimensions: 330x220mm



## HEAD CUSHION

HBO-0699 € 54,50 (C)

Velour material.



# SPECIFIC BRACKETS

FIA 8862 - 2009

FIA 8855 - 2021

OMP can design, produce and homologate custom brackets upon request for any seat according to customer needs. Brackets can be developed for any FIA standard (Technical list. 40 and 91 and Art. 253).

## SEAT BRACKETS FOR HTE ONE LITE

HC0-0934 € 470,00 (D)  
FIA 8862-2009



## RALLY SEAT BRACKETS FOR HTE ONE E

HC0-0940 UPON REQUEST  
FIA 8862-2009



## SEAT BRACKETS FIA 8862-2009

HC0-0880-A01 for HTE ONE € 309,00 (D)  
HC0-0880-A02 for HTE ONE S € 309,00 (D)  
HC0-0928 for HTE ONE XL € 452,00 (D)



## SEAT BRACKETS FOR HTE ONE - FOR HTE ONE 2

HC0-0935-A01 for HTC ONE € 1.600,00 (D)  
HC0-0935-A02 for HTC ONE E2 € 1.554,00 (D)



FIA 8862-2009

## SEAT BRACKETS FOR HTE ONE LITE

HC0-0951-A01 for HTE EVO 2 CARBON (CS.016.23)  
HC0-0951-A02 for HTE EVO (CS.017.23)  
HC0-0951-A03 for HTC EVO (CS.015.23)  
HC0-0951-A04 for HTE EVO 2 XL (CS.019.24)  
HC0-0951-A05 for HTE EVO 2 S € 260,00 (D)



FIA 8855-2021

## SEAT BRACKETS FIA 8862-2009

HC0-0907 for HRC ONE (AS.033.14) € 1.910,00 (D)  
HC0-0929-A01 for HRC ONE LITE (AS.075.19)  
HC0-0929-A02 for HRC ONE LITE RC (AS.083.19)



## SEAT BRACKETS FIA 8855-2021

**NEW**

HC0-0955 for HGT EVO € 150,00 (C)



HC0-0954 for HGT EVO € 140,00 (C)

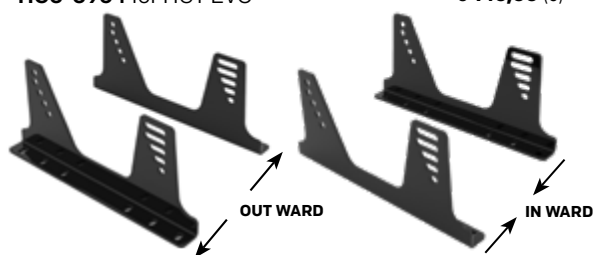

## SEAT BRACKETS FIA 8855-2021

HC0-0945 for HRC ONE (AS.033.14) € 160,00 (D)



# UNIVERSAL BRACKETS

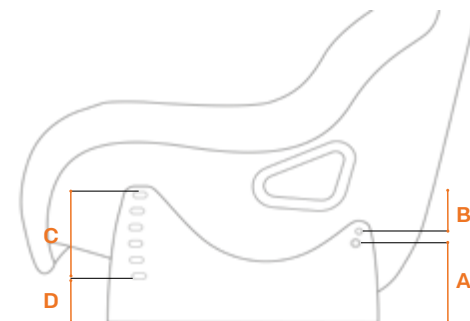

## SIDE MOUNT BRACKET DIMENSIONS

The dimensions are in mm.

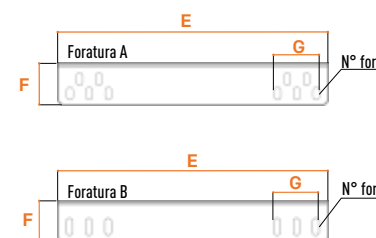

|               | Lowest rear mounting hole "A" | Rear range "B" | Front range "C" | Lowest front mounting hole "D" | Type of bolt pattern | Length of mounting plate "E" | Width of mounting plate "F" | Longitudinal range "G" | Number of holes |
|---------------|-------------------------------|----------------|-----------------|--------------------------------|----------------------|------------------------------|-----------------------------|------------------------|-----------------|
| <b>STAFFA</b> |                               |                |                 |                                |                      |                              |                             |                        |                 |
| HC0-0731-B01  | 110                           | 34.5           | 93              | 70.5                           | B                    | 350                          | 45                          | 75                     | 4               |
| HC0-0733-B01  | 109                           | 17             | 94              | 70.5                           | A                    | 350                          | 52                          | 25                     | 3               |
| HC0-0830      | 77                            | 66             | 66              | 77                             | B                    | 495                          | 48.5                        | 126                    | 6               |
| HC0-0830-B02  | 112                           | 51             | 108             | 73.5                           | A                    | 422.5                        | 59                          | 112.5                  | 10              |
| HC0-0922      | 85                            | 81             | 81              | 85                             | B                    | 400                          | 52                          | 75                     | 4               |
| HC0-0923      | 75.5                          | 100            | 100             | 75.5                           | B                    | 495                          | 50                          | 125                    | 6               |
| HC0-0924      | 85                            | 81             | 81              | 85                             | B                    | 400                          | 52                          | 75                     | 4               |
| HC0-0925      | 75.5                          | 100            | 100             | 75.5                           | B                    | 495                          | 50                          | 125                    | 6               |

## SEAT BRACKETS FIA APPENDIX J ART. 253

HC0-0922 € 125,00 (C)

Tall model. Steel.  
Length: 400 mm  
Thickness: 3 mm  
Ultra strong material.



## SEAT BRACKETS FIA APPENDIX J ART. 253

HC0-0731-B01 € 86,00 (C)

Tall model. Steel.  
Length: 350 mm  
Thickness: 3 mm  
Ultra strong material.



## SEAT BRACKETS FIA APPENDIX J ART. 253

HC0-0733-B01 € 66,00 (C)

Tall model. Steel.  
Length: 350 mm  
Thickness: 3 mm  
Ultra strong material.



## SEAT BRACKETS FIA APPENDIX J ART. 253

HC0-0923 € 140,00 (C)

Tall model. Steel.  
Length: 495 mm  
Thickness: 3 mm  
Ultra strong material.



## ALUMINIUM BRACKETS

HC0-0924 € 154,00 (C)

Tall model. Aluminium.  
Length: 400 mm  
Thickness: 6 mm  
Ultra strong material.



FIA APPENDIX J ART. 253

## ALUMINIUM BRACKETS

HC0-0925 € 172,00 (C)

Tall model. Aluminium.  
Length: 495 mm  
Thickness: 6 mm  
Ultra strong material.



FIA APPENDIX J ART. 253

## SEAT BRACKETS FIA APPENDIX J ART. 253

HC0-0830 € 366,00 (C)

Tall model equipped with a damper. Aluminium. Patented model. Length: 495 mm  
Thickness: 6 mm  
DAMPING ELEMENT to reduce vertical loads on the driver. Suitable for off-road.

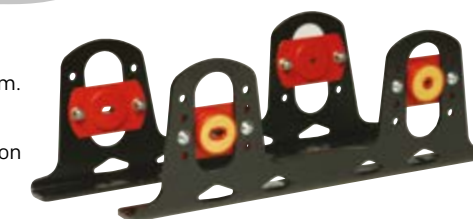

# BRACKETS AND ADAPTORS FOR LOWER FIXING HOLES

## UNIVERSAL SUBFRAME

**HDO-0879** € 119,00 (C)

Weld-in universal seat subframe to be adapted to the shell of the vehicle. Two 35 mm squared pipes. Length: 600 mm

4 plates for direct welding to the body (80x60) thickness 3 mm).

4 plates for direct welding to the tube (60x40) thickness 3 mm)

4 buckles for welding M8.

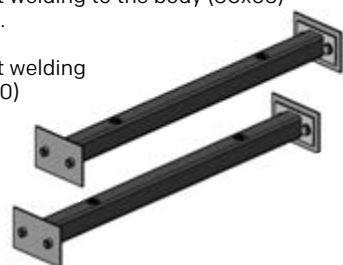

## SEAT BRACKET SPACER

**HCO-0857** € 129,00 (A)

Seat bracket spacer allows the seat height to be adjusted, depending on which side is used for mounting. Not FIA homologated.

**Height:** + 25 mm or + 50 mm above the vehicle specific adaptor.

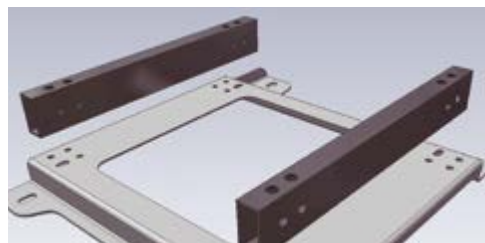

## SEAT BRACKET SPACER

**HCO-0858** € 181,00 (A)

Seat bracket spacer to consent seat adjustment. **Height:** + 50 mm, + 62 mm and + 75 mm respect to the vehicle specific adaptor.

**Inclination:** 2.5° or 5° seat angle adjustments.



## STEEL BRACKETS

**HCO-0660** € 94,00 (C)

Pair of "L" shaped brackets to fit seats with lower attachment points (type Y) to side brackets. Steel. Thickness: 3 mm



## SLIDING RAIL

**HDO-0666** € 126,00 (A)

Universal couple of brackets for seat with lower attachments. Aluminium Not FIA approved.



## SEAT BRACKETS

**HCO-0665** € 52,00 (A)

Sliding rail kit to be mounted between the brackets and the seat. Steel. Not FIA approved.



## ADAPTORS FOR SEAT FIXING BRACKETS

**HCO-....** € 114,00 (A)

Search Complete Application List, for the complete list of available items also on [www.ompracing.com](http://www.ompracing.com)

SEE THE APPLICATION LIST ON:

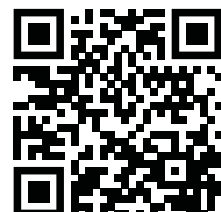

Sample image

# SEATS MOUNTING EXAMPLES

## Seat with side attachments points

1. Side mounting brackets (Racing)
2. Sliding brackets (HC/665)
3. Seat mounting bracket (vehicle specific)

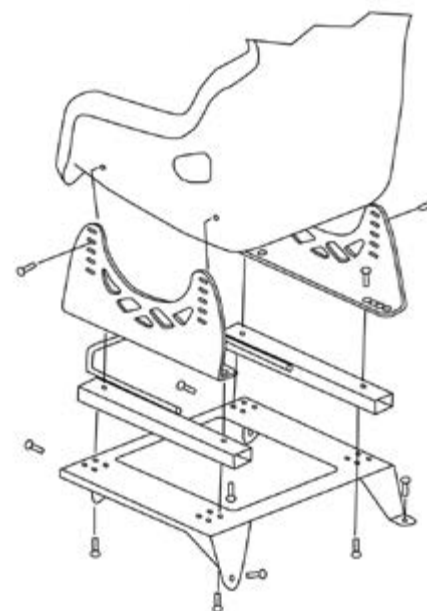

## Seat with lower attachments points

1. Sliding brackets (HC/665)
2. Optional seat bracket spacer (HC/857 or HC/858)
3. Seat mounting bracket (vehicle specific)

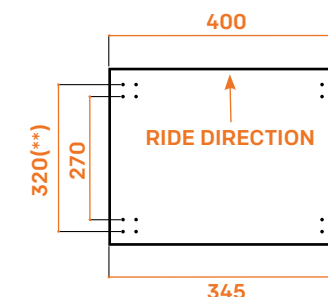
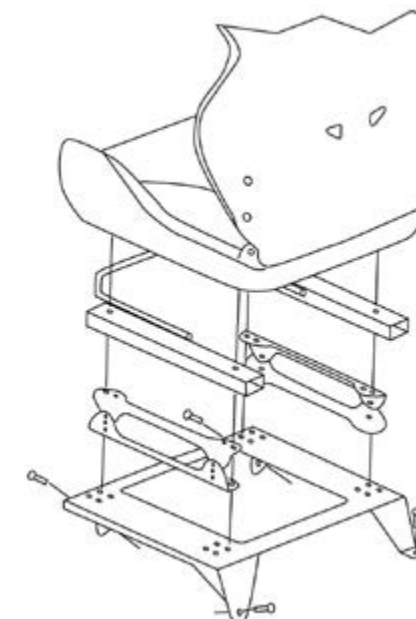



GIVES YOU WINGS

BELL

A14 MANAGEMENT

OMP

KIRO RACING

# SAFETY HARNESSSES

# COMPETITION HARNESS

# TECHNICAL FEATURES



**A** Ultralightweight buckle with anti-unwitting opening system. FIA 8853/2016



**B** Professional buckle. FIA 8853/2016



**C** Professional ultra lightweight 2" quick release adjuster made of high strength forged aluminum, designed to minimize the weight and slipping of the webbing, ergonomic and compact.



**D** Professional ultra lightweight 3" quick release adjuster made of high strength forged aluminum, designed to minimize the weight and slipping of the webbing, ergonomic and compact.



**E** Professional ultra lightweight integrated quick release adjuster made of high strength forged aluminum, designed to minimize the weight, ergonomic and compact.



**F** Exclusive double pin T-bar crotch attachment



**G** Compact lightweight quick release adjuster made of steel and high strength aluminum, ergonomic and compact.



**H** Professional adjuster made of high strength steel.



**I** Ultra lightweight Dyneema®, the world strongest fiber™ straps with comfortable webbings.



**L** Lightweight polyester straps with comfortable webbings.



**M** Lightweight steel snap hook.

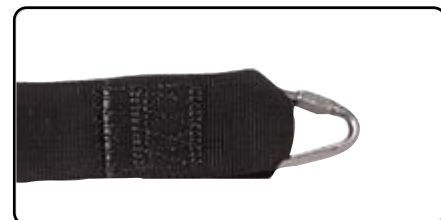

**N** Lightweight steel carabiner.



**O** Plate attachment.



**P** Snap hook attachment made of steel with high mechanical strength designed to improve performance and for optimum safety.



**Q** Webbing end sewn specifically for formula cars attach.



**R** Homologated for direct attachment to rollbars.



**S** Buckle fixed to the lap strap.



**T** Buckle fixed to the crotch strap.



**U** Runner for fixing intercom connectors.



**V** Runner for use with rubber bands - specifically for GT cars.

All safety harnesses can be customized upon request according to the customer needs



FIA presentation form

# ONE D

DA0-0102-A01 € 530,00 (C)

6 POINTS FHR ONLY

## SALOON PULL UP OR PULL DOWN

- Ultralightweight and comfortable safety harness for saloon cars, made of Dyneema® — the world's strongest fiber™
- Forged aluminium ultralight adjusters
- Buckle in ergal, machined from solid, and magnesium components
- Ultra-resistant buckle with anti-unwitting opening system for maximum safety
- Exclusive double pin T-bar crotch attachments
- Adjustable shoulder and lap straps with F1-inspired "double fold" system for a practical and secure hold







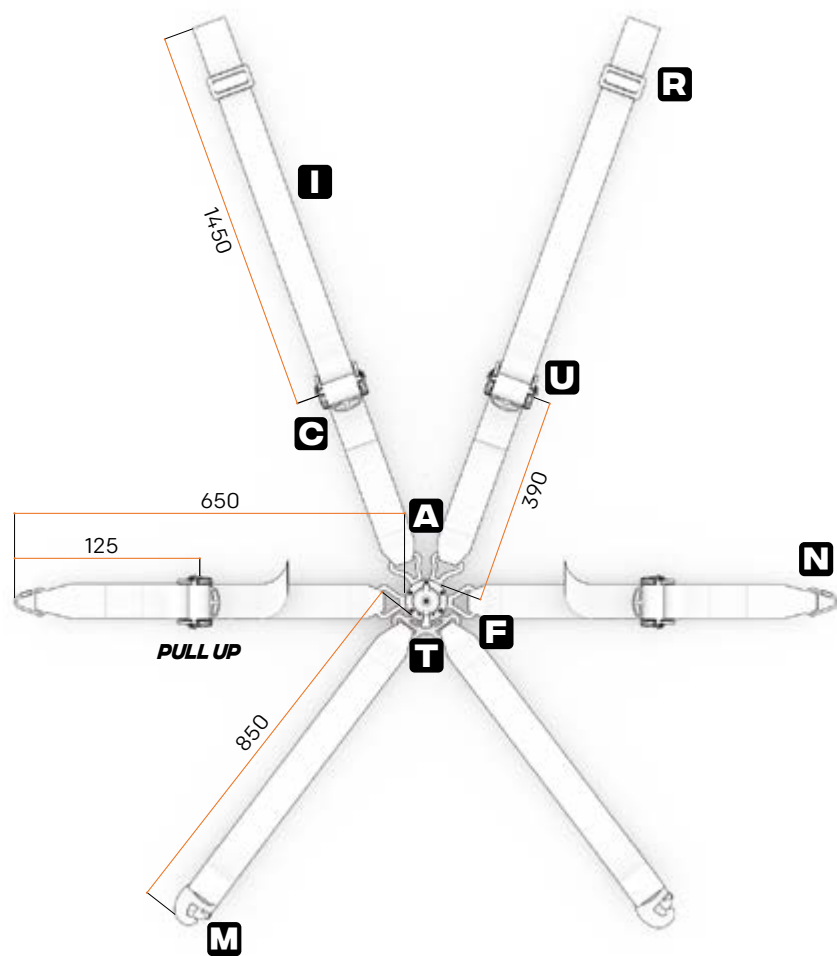

ALSO AVAILABLE IN MAGNESIUM-FREE VERSION UPON REQUEST :

- (DA0-0102-A02 PULL DOWN)
- (DA0-0102-A04 PULL UP)

WITH Dyneema®  
50% LIGHTER  
15% MORE RESISTANT



MEASUREMENTS IN MM

|   |  |   |
|---|--|---|
| <br><b>I</b><br>ULTRALIGHT DYNEEMA                             | <br><b>C</b><br>PROFESSIONAL ULTRA LIGHTWEIGHT ADJUSTER      | <br><b>N</b><br>LIGHTWEIGHT STEEL CARABINER      |
| <br><b>A</b><br>ULTRALIGHTWEIGHT BUCKLE ANTI-UNWITTING OPENING | <br><b>U</b><br>FIXING INTERCOM CONNECTORS                   | <br><b>M</b><br>LIGHTWEIGHT STEEL SNAP HOOK      |
| <br><b>R</b><br>HOMOLOGATED FOR ROLL BAR                       | <br><b>F</b><br>EXCLUSIVE DOUBLE PIN T-BAR CROUCH ATTACHMENT | <br><b>T</b><br>BUCKLE FIXED TO THE CROUCH STRAP |

# SALOON PULL DOWN



DA0-0102-A03 **SALOON PULL UP**



Please refer to the proper FIA presentation form for each harness for a complete overview of all homologated alternative attachment options

DA0-0210-A01 € 375,00 (C)

6 POINTS  
FHR ONLY

## SALOON PULL UP

- Lightweight and comfortable safety harness for saloon cars, made of polyester fabric
- Forged aluminium ultralight adjusters
- Buckle in ergal, machined from solid
- Ultra-resistant buckle with anti-unwitting opening system for maximum safety
- Exclusive double pin T-bar crotch attachments
- FHR only

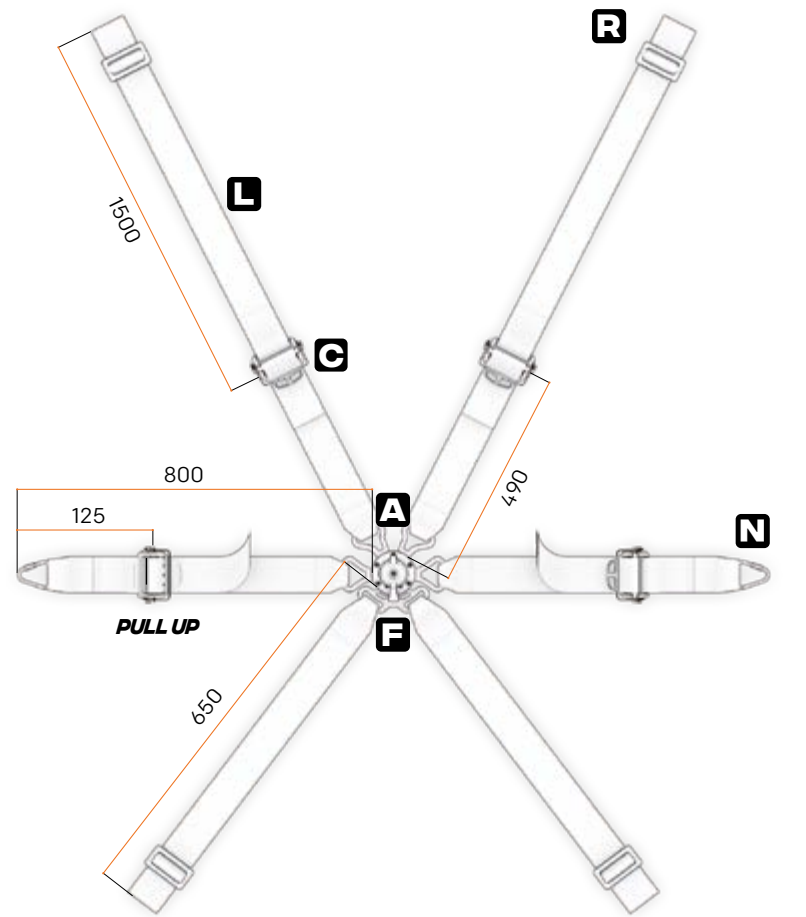

MEASUREMENTS IN MM



L LIGHTWEIGHT POLYESTER STRAPS



C PROFESSIONAL ULTRA LIGHTWEIGHT ADJUSTER



N LIGHTWEIGHT STEEL CARABINER



A ULTRALIGHTWEIGHT BUCKLE ANTI-UNWITTING OPENING



T BUCKLE FIXED TO THE CROUCH STRAP



F EXCLUSIVE DOUBLE PIN T-BAR CROUCH ATTACHMENT



R HOMOLOGATED FOR ROLL BAR



MANUFACTURER: OMP  
MODEL: DA0210  
HOM. NO: SH.084.21-T-6  
FIA STANDARD: FIA 8853-2016



Please refer to the proper FIA presentation form for each harness for a complete overview of all homologated alternative attachment options

# ONE 2<sup>nd</sup> ENDURANCE

DA0-0211-A02 € 435,00 (C)

6 POINTS FHR ONLY

## SALOON PULL DOWN

- Lightweight and comfortable safety harness for saloon cars, made of Dyneema® and polyester fabric
- Forged aluminium ultralight adjusters
- Quick-release buckle in ergal, machined from solid
- Quick adjusters for fast and precise strap setting
- Fluo reflective inserts for maximum visibility, even at night
- FHR only

WITH Dyneema® **50% LIGHTER**  
**15% MORE RESISTANT**

## NEW LOW-PROFILE T-BAR ATTACHMENT



EXCLUSIVE NEW DOUBLE PIN T-BAR CROTCH ATTACHMENT

**FIA APPROVED**

MANUFACTURER: OMP  
MODEL: DA0211  
HOM. NO: SH.94.22-T-6  
FIA STANDARD: FIA 8853-2016

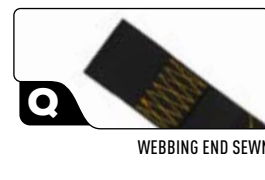
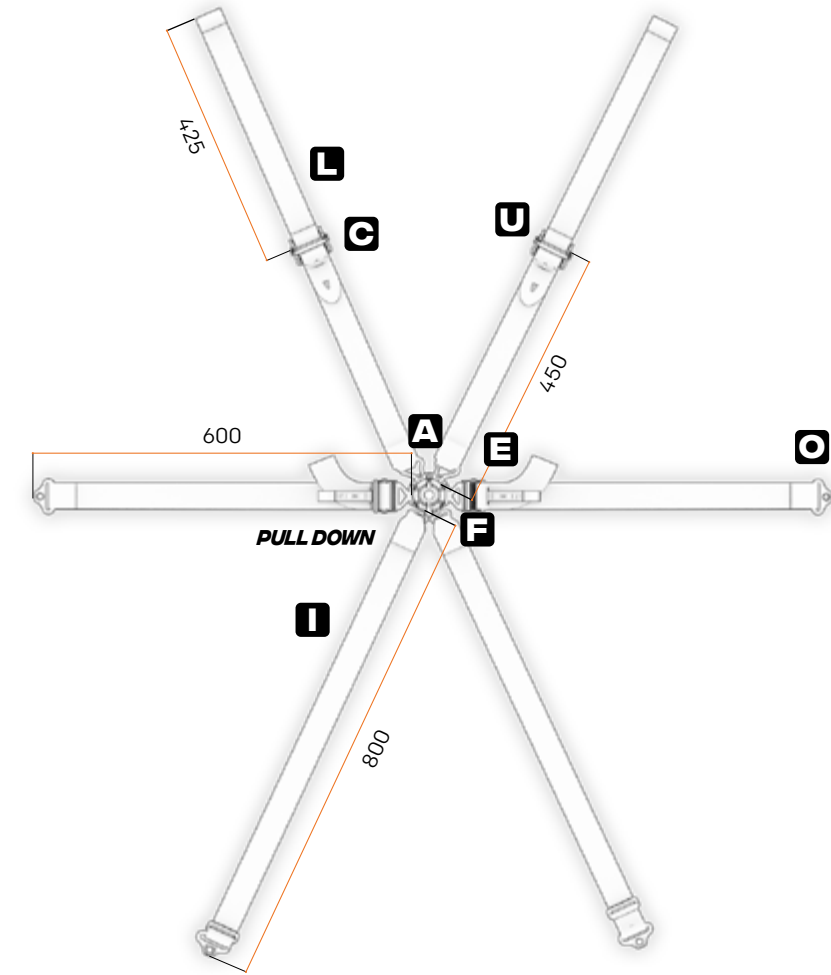

# SALOON PULL DOWN



Please refer to the proper FIA presentation form for each harness for a complete overview of all homologated alternative attachment options

# ONE 2 VERSA ENDURANCE

DAO-0202-A05 € 375,00 (C)

6 POINTS FHR ONLY

## SALOON PULL DOWN

- Lightweight, comfortable and versatile safety harness for saloon cars, made of polyester fabric
- Forged aluminium ultralight adjusters.
- Buckle in ergal, machined from solid, and magnesium components
- Ultra-resistant buckle with anti-unwitting opening system for maximum safety
- Exclusive double pin T-bar crotch attachments
- Quick adjusters on crotch straps
- ENDURANCE lap straps with pull-down adjustment
- FHR only



DAO-0202-A05-061 Red



DAO-0202-A05-071 Black



MANUFACTURER: OMP  
MODEL: DA0202  
HOM. NO: SH.012.17-T-6  
FIA STANDARD: FIA 8853-2016

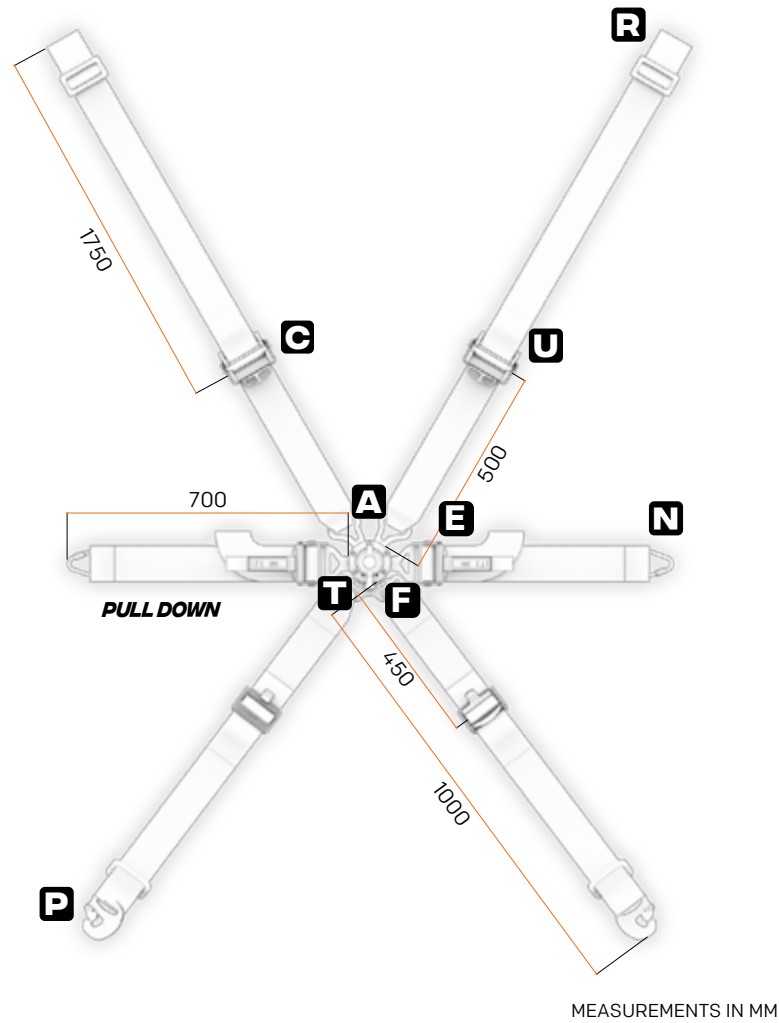

PROFESSIONAL LIGHTWEIGHT INTEGRATED ADJUSTER



ULTRA LIGHTWEIGHT ADJUSTER



LIGHTWEIGHT STEEL CARABINER



ULTRALIGHTWEIGHT BUCKLE ANTI-UNWITTING OPENING



FIXING INTERCOM CONNECTOR

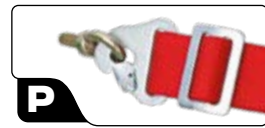

STEEL SNAP HOOK

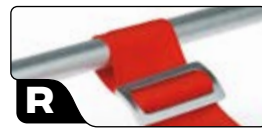

HOMOLOGATED FOR ROLL BAR



EXCLUSIVE DOUBLE PIN T-BAR CROUCH ATTACHMENT



BUCKLE FIXED TO THE CROUCH STRAP

## SALOON PULL DOWN



Please refer to the proper FIA presentation form for each harness for a complete overview of all homologated alternative attachment options

# ONE 2

DA0-0202-A02 € 339,00 (C)

6 POINTS  
FHR ONLY

## SUPERLIGHT PROFESSIONAL SAFETY BELT SALOON PULL UP OR PULL DOWN

- Lightweight and comfortable safety harness for saloon cars, made of polyester fabric
- Forged aluminium ultralight adjusters.
- Buckle in ergal, machined from solid, and magnesium components
- Ultra-resistant buckle with anti-unwitting opening system for maximum safety
- Exclusive double pin T-bar crotch attachments
- FHR only



DA0-0202-A02-061 Red



DA0-0202-A02-071 BLACK



MANUFACTURER: OMP  
MODEL: DA0202  
HOM. NO: SH.012.17-T-6  
FIA STANDARD: FIA 8853-2016

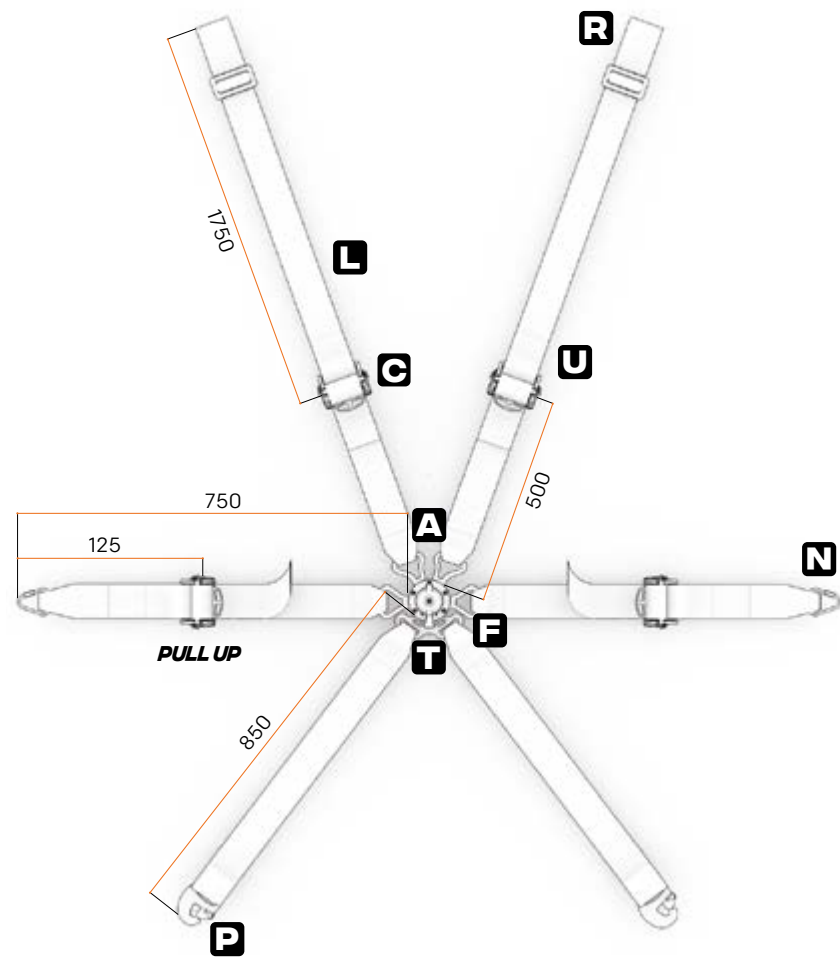

L LIGHTWEIGHT POLYESTER STRAPS



C ULTRA LIGHTWEIGHT ADJUSTER



N LIGHTWEIGHT STEEL CARABINER



A ULTRALIGHTWEIGHT BUCKLE ANTI-UNWITTING OPENING



U FIXING INTERCOM CONNECTOR



P STEEL SNAP HOOK



R HOMOLOGATED FOR ROLL BAR



F EXCLUSIVE DOUBLE PIN T-BAR CROUCH ATTACHMENT



T BUCKLE FIXED TO THE CROUCH STRAP

# SALOON PULL UP



DA0-0202-A01

SALOON PULL DOWN



Please refer to the proper FIA presentation form for each harness for a complete overview of all homologated alternative attachment options

# ONE 3+2 CONVERTIBLE

DAO-0205-A01 € 345,00 (C)

6 POINTS  
FHR ONLY

## SALOON PULL UP CONVERTIBLE IN PULL DOWN

- Lightweight and comfortable safety harness for saloon cars, made of polyester fabric
- Ultralight aluminium adjusters on shoulder straps
- Steel and high-strength aluminium lightweight adjusters on lap straps
- Buckle in ergal, machined from solid, and magnesium components
- Ultra-resistant buckle with anti-unwitting opening system for maximum safety
- Exclusive double pin T-bar crotch attachments
- Exclusive double pin T-bar crotch attachments



DAO-0205-A01-061 Red



DAO-0205-A01-071 Black



MANUFACTURER: OMP  
MODEL: DA0205  
HOM. NO: SH.052.18-T-6  
FIA STANDARD: FIA 8853-2016

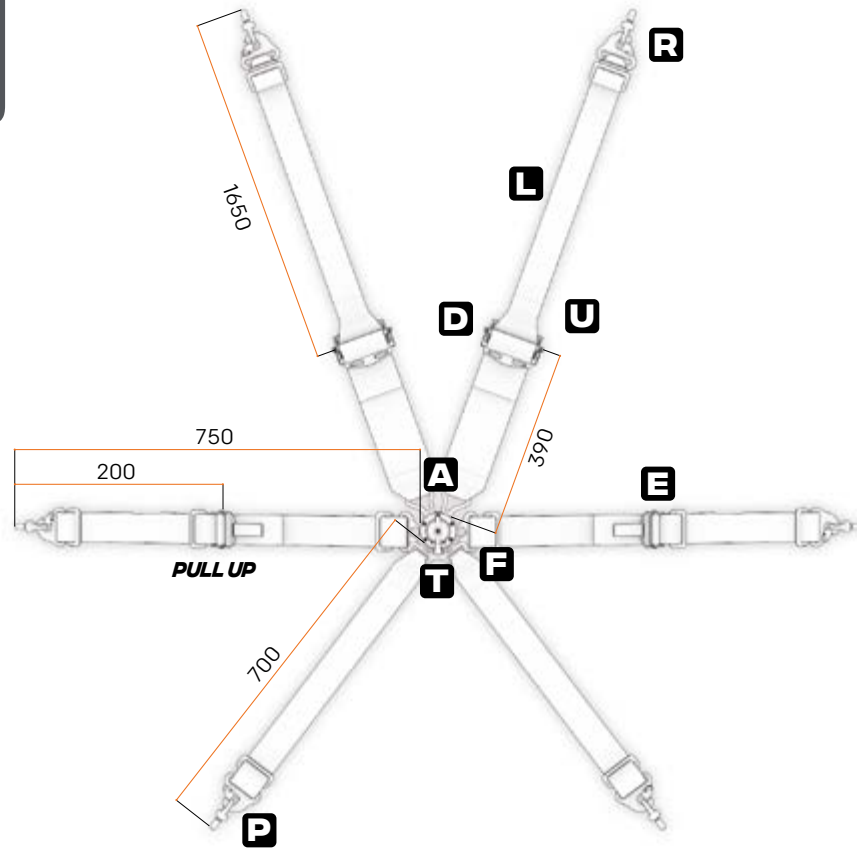

MEASUREMENTS IN MM



L LIGHTWEIGHT POLYESTER STRAPS



D ULTRA LIGHTWEIGHT ADJUSTER



F EXCLUSIVE DOUBLE PIN T-BAR CROUCH ATTACHMENT



A ULTRALIGHT BUCKLE



U FIXING INTERCOM CONNECTOR



P STEEL SNAP HOOK



R HOMOLOGATED FOR ROLL BAR



G PROFESSIONAL ULTRA LIGHTWEIGHT ADJUSTER



T BUCKLE FIXED TO THE CROUCH STRAP

# SALOON PULL UP



Please refer to the proper FIA presentation form for each harness for a complete overview of all homologated alternative attachment options

# ONE 3+2 ENDURANCE

DA0-0205-A02 € 335,00 (C)

6 POINTS  
FHR ONLY

## SALOON PULL UP ENDURANCE

- Lightweight and comfortable safety harness for saloon cars, made of polyester fabric
- Ultralight aluminium adjusters on shoulder straps
- Steel and high-strength aluminium lightweight endurance adjusters on lap straps
- Buckle in ergal, machined from solid, and magnesium components
- Ultra-resistant buckle with anti-unwitting opening system for maximum safety.
- Exclusive double pin T-bar crotch attachments



DA0-0205-A02-061 Red



DA0-0205-A02-071 Black



MANUFACTURER: OMP  
MODEL: DA0205  
HOM. NO: SH.052.18-T-6  
FIA STANDARD: FIA 8853-2016

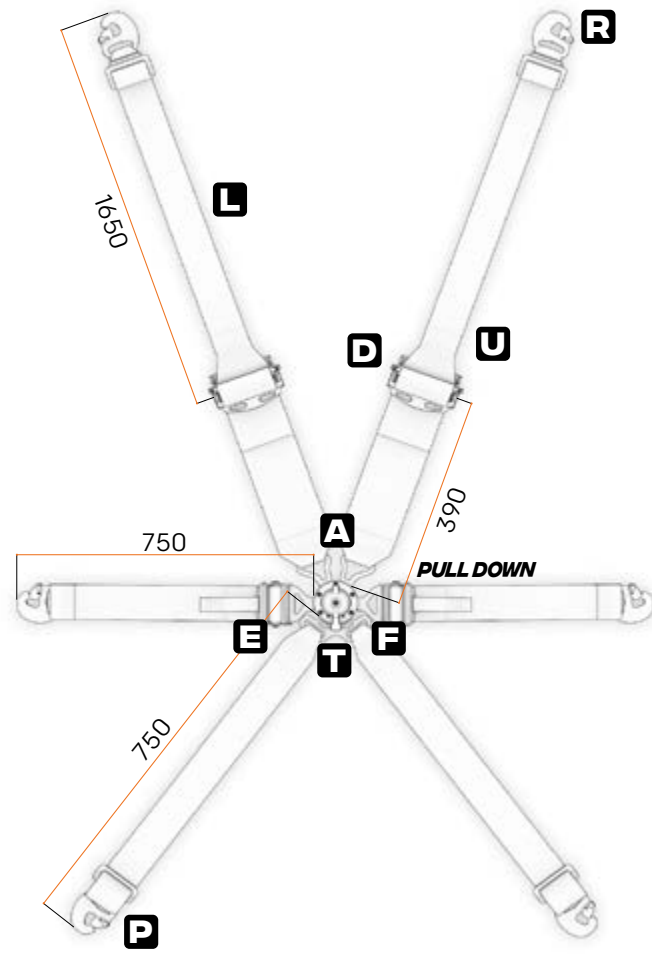

MEASUREMENTS IN MM



L LIGHTWEIGHT POLYESTER STRAPS



E PROFESSIONAL LIGHTWEIGHT INTEGRATED ADJUSTER



F EXCLUSIVE DOUBLE PIN T-BAR CROUCH ATTACHMENT



A ULTRALIGHT BUCKLE



U FIXING INTERCOM CONNECTOR

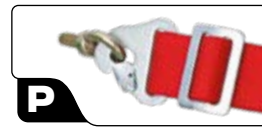

P STEEL SNAP HOOK



R HOMOLOGATED FOR ROLL BAR



D PROFESSIONAL ULTRA LIGHTWEIGHT 3" QUICK RELEASE ADJUSTER



T BUCKLE FIXED TO THE CROUCH STRAP

# SALOON PULL DOWN



Please refer to the proper FIA presentation form for each harness for a complete overview of all homologated alternative attachment options

DAO-0203-A01 € 265,00 (C)

6 POINTS  
FHR FRIENDLY

## SALOON PULL UP

- Lightweight and comfortable safety harness for saloon cars, made of polyester fabric
- Steel and high-strength aluminium lightweight adjusters
- Buckle in ergal, machined from solid, and magnesium components
- Ultra-resistant buckle with anti-unwitting opening system for maximum safety
- Exclusive double pin T-bar crotch attachments



DAO-0203-A01-061 Red



DAO-0203-A01-071 Black



MANUFACTURER: OMP  
MODEL: DAO203  
HOM. NO: SH.026.17-T-6  
FIA STANDARD: FIA 8853-2016

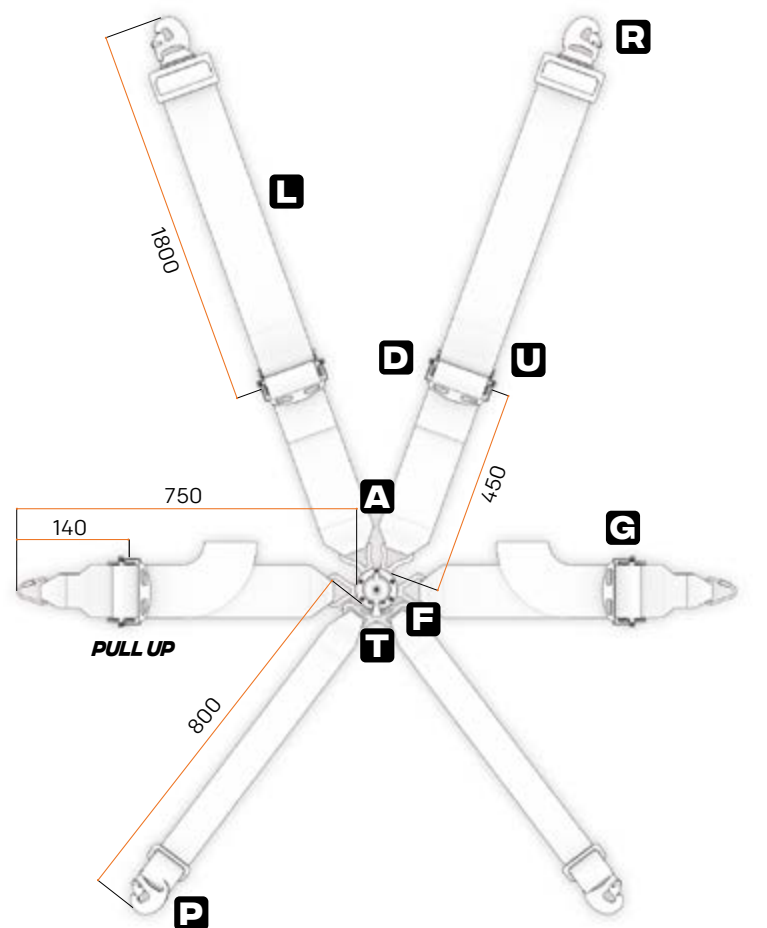

MEASUREMENTS IN MM



L LIGHTWEIGHT POLYESTER STRAPS



D PROFESSIONAL ULTRA LIGHTWEIGHT 3" QUICK RELEASE ADJUSTER



F EXCLUSIVE DOUBLE PIN T-BAR CROUCH ATTACHMENT



A ULTRALIGHT BUCKLE



U FIXING INTERCOM CONNECTOR



P STEEL SNAP HOOK



R HOMOLOGATED FOR ROLL BAR



T BUCKLE FIXED TO THE CROUCH STRAP



Please refer to the proper FIA presentation form for each harness for a complete overview of all homologated alternative attachment options

# TECNICA

## 3+2

DAO-0203-A02 € 265,00 (C)

6 POINTS  
FHR ONLY

### SALOON PULL UP

- Lightweight and comfortable safety harness for saloon cars, made of polyester fabric
- Ultralight aluminium adjusters on shoulder straps
- Steel and high-strength aluminium lightweight adjusters on lap straps
- Buckle in ergal, machined from solid, and magnesium components
- Ultra-resistant buckle with anti-unwitting opening system for maximum safety
- Exclusive double pin T-bar crotch attachments
- Exclusive double pin T-bar crotch attachments



DAO-0203-A02-061 Red



DAO-0203-A02-071 Black



MANUFACTURER: OMP  
MODEL: DA0203  
HOM. NO: SH.026.17-T-6  
FIA STANDARD: FIA 8853-2016

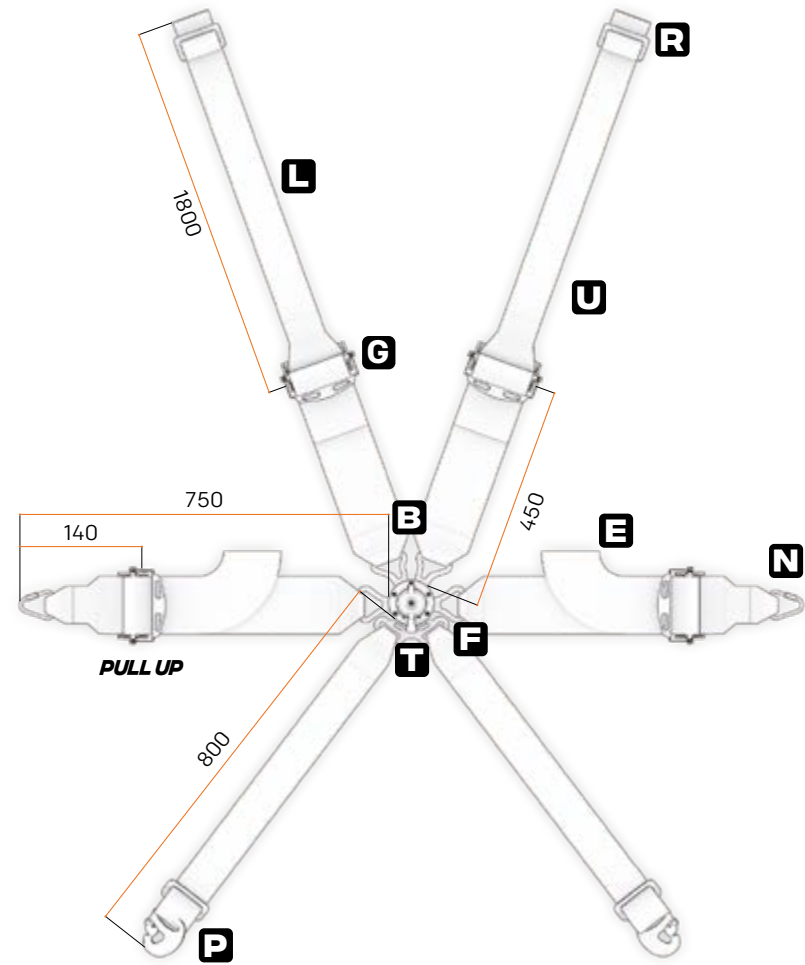

MEASUREMENTS IN MM



L LIGHTWEIGHT POLYESTER STRAPS



D LIGHTWEIGHT QUICK RELEASE 3" ADJUSTER



F EXCLUSIVE DOUBLE PIN T-BAR CROUCH ATTACHMENT



B ULTRALIGHT BUCKLE



U FIXING INTERCOM CONNECTOR



P STEEL SNAP HOOK



R HOMOLOGATED FOR ROLL BAR



N SMALL SIZE CARABINER



T BUCKLE FIXED TO THE CROUCH STRAP

## SALOON PULL UP



Please refer to the proper FIA presentation form for each harness for a complete overview of all homologated alternative attachment options

# FIRST 3

DAO-0204-B01 € 220,00 (C)

6 POINTS  
FHR FRIENDLY

## SALOON PULL UP ENTRY LEVEL 3"

- Lightweight and comfortable safety harness for saloon cars, made of polyester fabric
- Strong steel adjusters for durability and reliability
- Buckle in aluminium and steel, offering an improved quality/price ratio while maintaining the same performance level



DAO-0204-B01-061 Red



DAO-0204-B01-061 Black

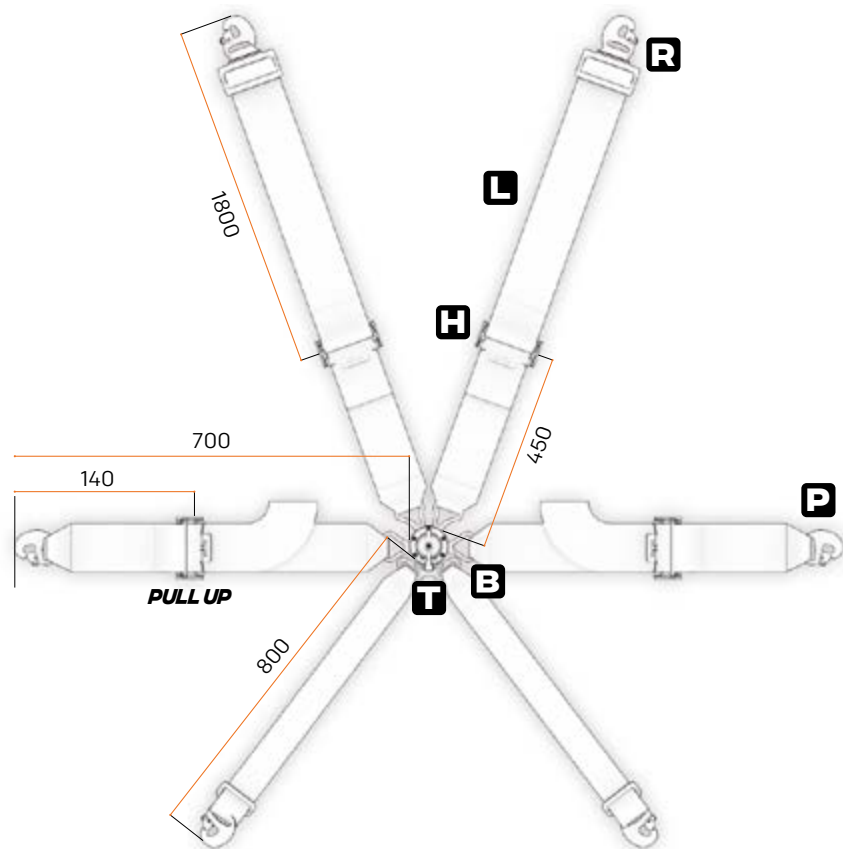

MEASUREMENTS IN MM



L LIGHTWEIGHT POLYESTER STRAPS



H PROFESSIONAL STEEL ADJUSTER



P STEEL SNAP HOOK



R HOMOLOGATED FOR ROLL BAR



B PROFESSIONAL BUCKLE



T BUCKLE FIXED TO THE CROTCH STRAP

# SALOON PULL UP



Please refer to the proper FIA presentation form for each harness for a complete overview of all homologated alternative attachment options



MANUFACTURER: OMP  
MODEL: DA0204  
HOM. NO: SH.036.17-T-6  
FIA STANDARD: FIA 8853-2016

# FIRST 3+2

DAO-0204-B02 € 210,00 (C)

6 POINTS  
FHR ONLY

## SALOON PULL UP ENTRY LEVEL 3"+2"

- Lightweight and comfortable entry-level safety harness for saloon cars, made of polyester fabric
- Steel adjusters on lap straps
- Steel and aluminium adjusters on shoulder straps
- Buckle in aluminium and steel, offering an improved quality/price ratio while maintaining the same performance level

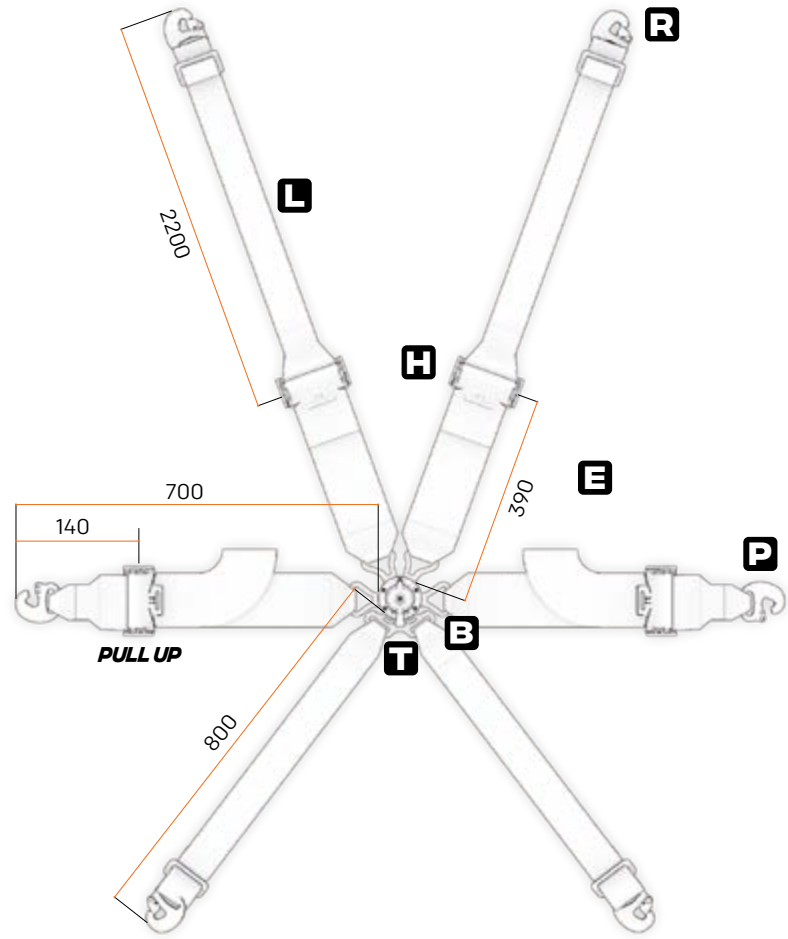

MEASUREMENTS IN MM



LIGHTWEIGHT POLYESTER STRAPS



PROFESSIONAL STEEL ADJUSTER



STEEL SNAP HOOK



HOMOLOGATED FOR ROLL BAR



PROFESSIONAL BUCKLE



BUCKLE FIXED TO THE CROTCH STRAP

# SALOON PULL UP



Please refer to the proper FIA presentation form for each harness for a complete overview of all homologated alternative attachment options



MANUFACTURER: OMP  
MODEL: DA0204  
HOM. NO: SH.036.17-T-6  
FIA STANDARD: FIA 8853-2016

# FIRST 2

DA0-0208-A01 € 199,00 (C)

6 POINTS  
FHR ONLY

## SALOON PULL UP ENTRY LEVEL 2"

- Lightweight and comfortable safety harness for saloon cars, made of polyester fabric
- Strong steel adjusters for reliability and durability
- Buckle in aluminium and steel, offering an improved quality/price ratio while maintaining the same performance level



DA0-0208-A01-061 Red



DA0-0208-A01-071 Black



MANUFACTURER: OMP  
MODEL: DA0208  
HOM. NO: SH.068.19-T-6  
FIA STANDARD: FIA 8853-2016

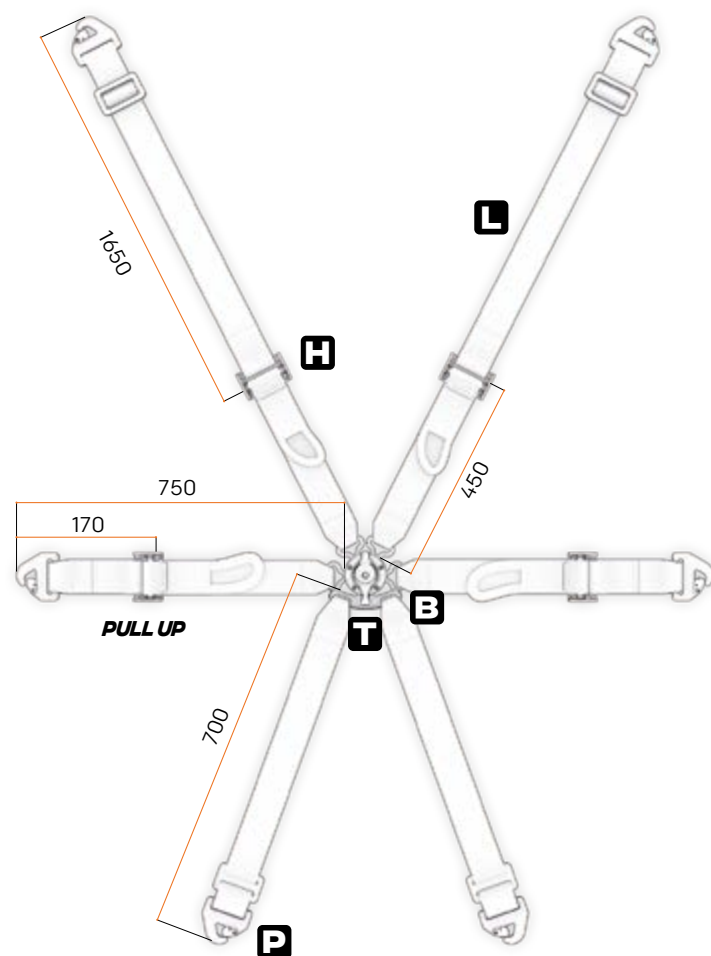

MEASUREMENTS IN MM



L LIGHTWEIGHT POLYESTER STRAPS



H PROFESSIONAL STEEL ADJUSTER



P STEEL SNAP HOOK



B PROFESSIONAL BUCKLE



T BUCKLE FIXED TO THE CROTCH STRAP

# SALOON PULL UP



Please refer to the proper FIA presentation form for each harness for a complete overview of all homologated alternative attachment options

# FIRST 3 4P

DAO-0801-B01 € 195,00 (C)

4 POINTS  
FHR FRIENDLY

## PULL UP PROFESSIONAL BELT

- 4-point safety harness for saloon cars with 3" straps.
- Ultralightweight adjusters
- Homologated for rollbar use
- Steel snap hooks
- Fixed lap strap buckle



DAO-0801-B01-061 Red



DAO-0801-B01-071 Black

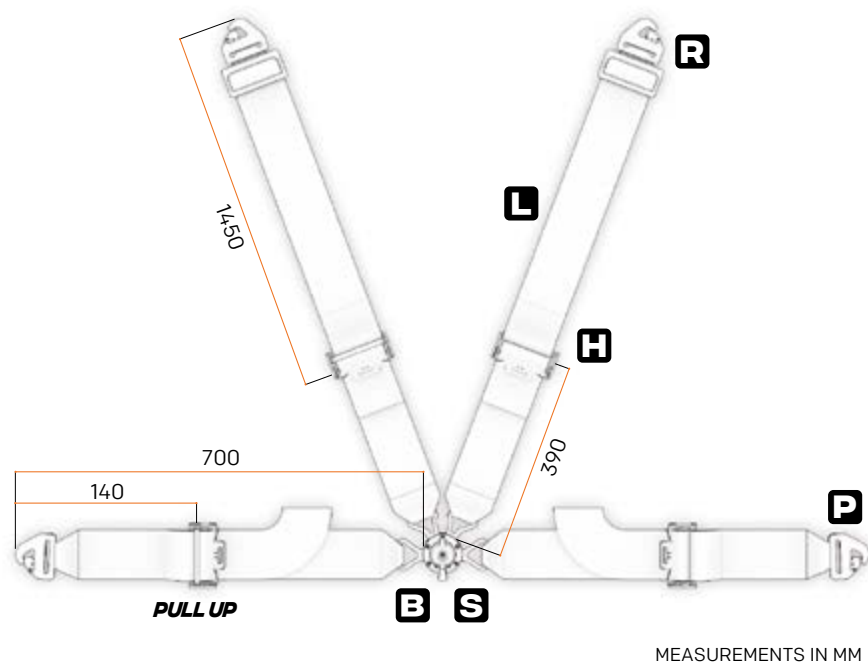

L LIGHTWEIGHT POLYESTER STRAPS



H PROFESSIONAL STEEL ADJUSTER



P STEEL SNAP HOOK



R HOMOLOGATED FOR ROLL BAR



S BUCKLE FIXED TO THE LAP STRAP

## SALOON PULL UP



Please refer to the proper FIA presentation form for each harness for a complete overview of all homologated alternative attachment options



MANUFACTURER: OMP  
MODEL: DA801  
HOM. NO: B-252.T/98  
FIA STANDARD: FIA 8854/98

# ONE-D 2 PROTOTYPE

DA0-0102-A05 € 530,00 (C)

6 POINTS  
FHR ONLY

## SALOON PULL UP OR PULL DOWN

- Ultralightweight and comfortable safety harness for prototype cars, made of Dyneema® — the world's strongest fiber™
- Forged aluminium ultralight adjusters
- Buckle in ergal, machined from solid, and magnesium components
- Ultra-resistant buckle with anti-unwitting opening system for maximum safety
- Exclusive double pin T-bar crotch attachments
- Adjustable shoulder and lap straps with F1-inspired "double fold" system for a practical and secure hold

WITH  
Dyneema®  
**50% LIGHTER**  
**15% MORE RESISTANT**

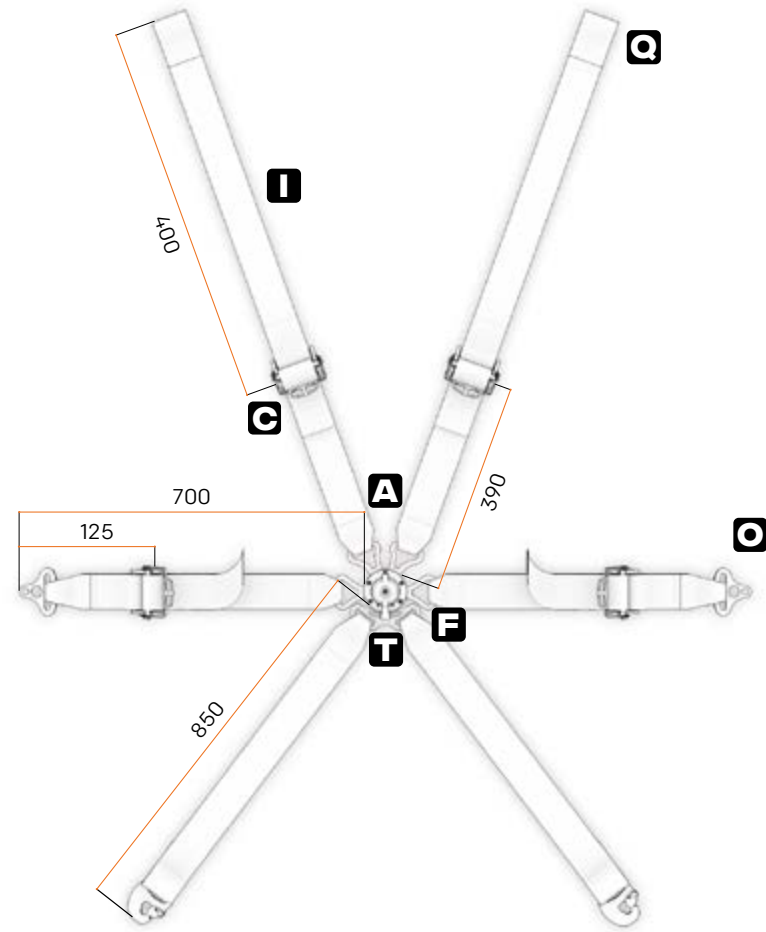

MEASUREMENTS IN MM



I  
ULTRALIGHT DYNEEMA



C  
PROFESSIONAL ULTRA LIGHTWEIGHT ADJUSTER



O  
PLATE ATTACHMENT



A  
ULTRALIGHTWEIGHT BUCKLE  
ANTI-UNWITTING OPENING



T  
BUCKLE FIXED TO THE CROTCH STRAP



Q  
WEBBING END SEWN FOR  
FORMULA CARS ATTACH



F  
EXCLUSIVE DOUBLE PIN T-BAR  
CROTCH ATTACHMENT

# FORMULA PULL UP



Please refer to the proper FIA presentation form for each harness for a complete overview of all homologated alternative attachment options

# ONE-D 2 FORMULA

DA0-0104-A01 € 530,00 (C)

6 POINTS  
FHR ONLY

## FORMULA BELT

- Ultralightweight and comfortable safety harness for **Formula** cars, made of Dyneema® — the world's strongest fiber™
- Forged aluminium ultralight adjusters
- Buckle in ergal, machined from solid, and magnesium components
- Ultra-resistant buckle with anti-unwitting opening system for maximum safety
- Exclusive double pin T-bar crotch attachments
- Adjustable shoulder straps with F1-inspired "double fold" system for a practical and secure hold

WITH  
Dyneema®  
**50% LIGHTER**  
**15% MORE RESISTANT**

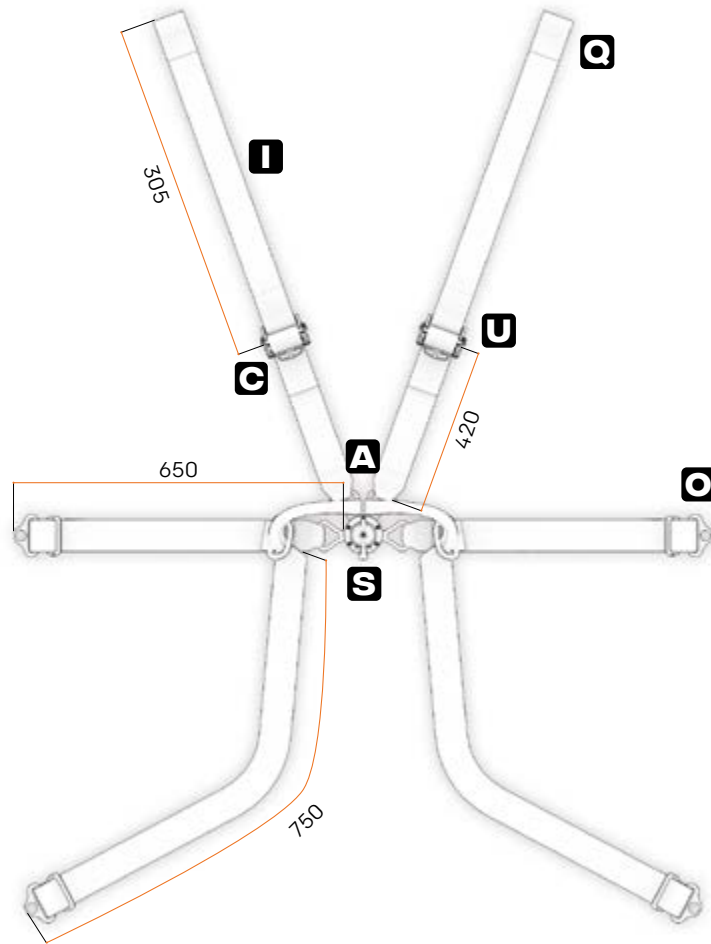

MEASUREMENTS IN MM



**I** ULTRALIGHT DYNEEMA



**C** PROFESSIONAL ULTRA LIGHTWEIGHT ADJUSTER



**O** PLATE ATTACHMENT



**A** ULTRALIGHTWEIGHT BUCKLE ANTI-UNWITTING OPENING



**U** FIXING INTERCOM CONNECTOR



**Q** WEBBING END SEWN FOR FORMULA CARS ATTACH



**S** BUCKLE FIXED TO THE LAP STRAP

# FORMULA



Please refer to the proper FIA presentation form for each harness for a complete overview of all homologated alternative attachment options

FIA APPROVED

MANUFACTURER: OMP  
MODEL: DA0104E  
HOM. NO: SH.097.23-T-6  
FIA STANDARD: FIA 8853-2016

# TECNICA 2 FORMULA

DA0-0206-A01 € 279,00 (C)

6 POINTS  
FHR ONLY

## SUPERLIGHT PROFESSIONAL BELT

- Lightweight and comfortable safety harness for formula cars, made of polyester fabric
- Forged aluminium ultralight adjusters
- Buckle in ergal, machined from solid, and magnesium components
- Ultra-resistant buckle for maximum safety

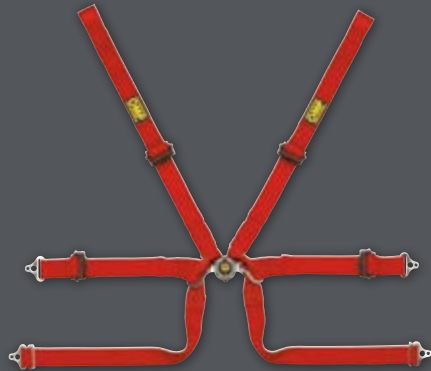

DA0-0206-A01-061 Red

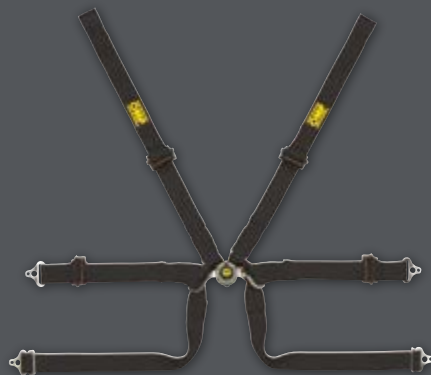

DA0-0206-A01-071 Black



MANUFACTURER: OMP  
MODEL: DA0206  
HOM. NO: SH.03717-T-6  
FIA STANDARD: FIA 8853-2016

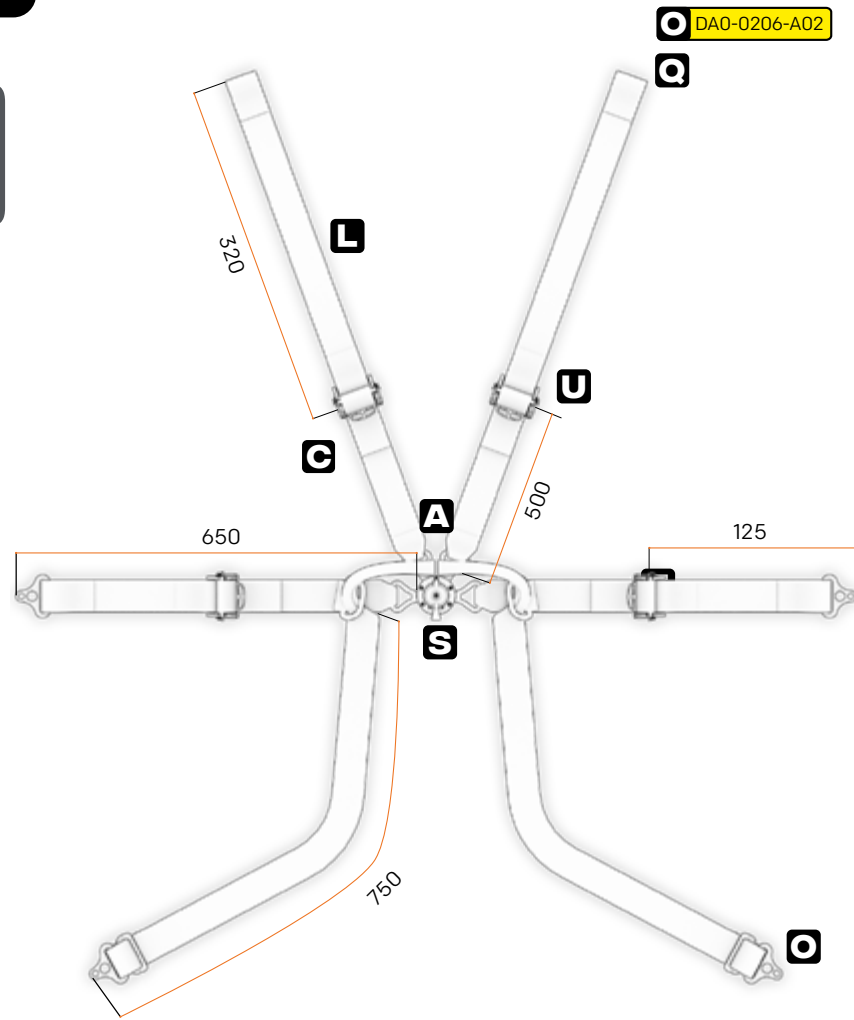

MEASUREMENTS IN MM



L LIGHTWEIGHT POLYESTER STRAPS



C ULTRA LIGHTWEIGHT ADJUSTER



Q PLATE ATTACHMENT



A ULTRALIGHT BUCKLE



U FIXING INTERCOM CONNECTOR

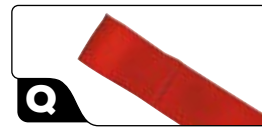

Q WEBBING END SEWN FOR FORMULA CARS ATTACH

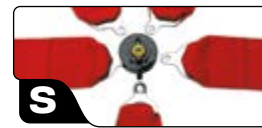

S BUCKLE FIXED TO THE LAP STRAP

# FORMULA PULL UP

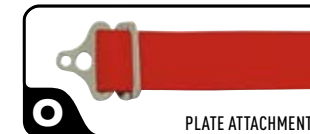

PLATE ATTACHMENT

ALSO AVAILABLE WITH PLATE ATTACHMENTS ON SHOULDER STRAPS: (DA0-0206-A02-071) Black (DA0-0206-A02-061) Red



Please refer to the proper FIA presentation form for each harness for a complete overview of all homologated alternative attachment options

# RACING HARNESSSES TABLE

## LEGEND

- A** maximum length upper shoulder strap
- B** maximum length lower shoulder strap
- C** maximum length lap strap
- D** fixed lap strap
- E** maximum length crotch strap
- F** maximum length upper crotch strap

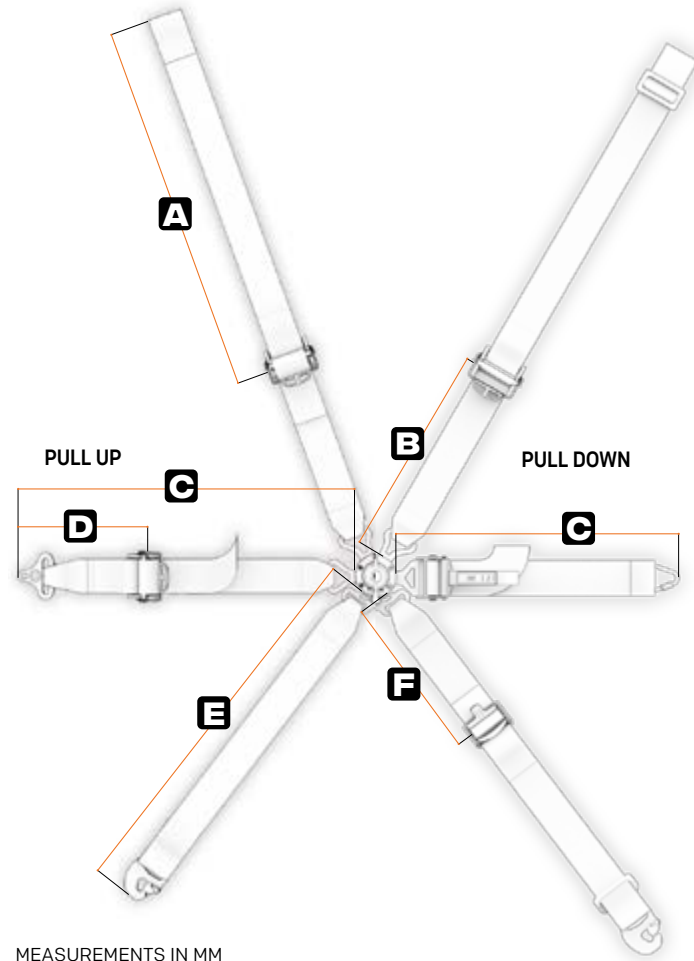

MEASUREMENTS IN MM



## FIA 8853 - 2016 SALOON

|  | MATERIAL             | POINTS | ADJUSTER    | PULL       | FHR      | SHOULDER BELT STRAP |                             | LAP BELT STRAP |                   | CROTCH BELT STRAP |                   | A    | B   | C   | D   | E    | F   |
|--|----------------------|--------|-------------|------------|----------|---------------------|-----------------------------|----------------|-------------------|-------------------|-------------------|------|-----|-----|-----|------|-----|
|  |                      |        |             |            |          | 2"                  | ROLLBAR ATTACH.             | 2"             | CARABINER ATTACH. | 2"                | SNAP HOOK ATTACH. |      |     |     |     |      |     |
| <b>ONE-D PULL UP</b><br>DA0-0102-A03<br><b>ONE-D PULL DOWN</b><br>DA0-0102-A01 | DYNEEMA              | 6      | ULTRA LIGHT | UP or DOWN | ONLY     | 2"                  | ROLLBAR ATTACH.             | 2"             | CARABINER ATTACH. | 2"                | SNAP HOOK ATTACH. | 1450 | 390 | 650 | 125 | 850  | /   |
| <b>ONE 2" WRC</b><br>DA0-0210-A01<br><b>ONE 2" WRC</b><br>DA0-0210-A04         | POLYESTER            | 6      | ULTRA LIGHT | UP         | ONLY     | 2"                  | ROLLBAR ATTACH.             | 2"             | SEWN CARABINER    | 2"                | ROLLBAR ATTACH.   | 1500 | 490 | 800 | 125 | 650  | /   |
| <b>ONE 2" ENDUR.</b><br>DA0-0211-A02   | DYNEEMA<br>POLYESTER | 6      | ULTRA LIGHT | DOWN       | ONLY     | 2"                  | SWN WEBB ATTACH.            | 2"             | PLATE ATTACH.     | 2"                | PLATE ATTACH.     | 425  | 450 | 600 | /   | 800  | /   |
| <b>ONE 2 VERSA END.</b><br>DA0-0202-A05  | POLYESTER            | 6      | ULTRA LIGHT | DOWN       | ONLY     | 2"                  | ROLLBAR ATTACH.             | 2"             | CARABINER ATTACH. | 2"                | SNAP HOOK ATTACH. | 1750 | 500 | 700 | /   | 1000 | 450 |
| <b>ONE 2 PULL UP</b><br>DA0-0202-A02<br><b>ONE 2 PULL DOWN</b><br>DA0-0202-A01 | POLYESTER            | 6      | ULTRA LIGHT | UP or DOWN | ONLY     | 2"                  | ROLLBAR ATTACH.             | 2"             | CARABINER ATTACH. | 2"                | SNAP HOOK ATTACH. | 1750 | 500 | 750 | 125 | 850  | /   |
| <b>ONE 3+2 CONV.</b><br>DA0-0205-A01   | POLYESTER            | 6      | ULTRA LIGHT | UP or DOWN | ONLY     | 2"<br>3"            | ROLLBAR / SNAP HOOK ATTACH. | 2"             | SNAP HOOK ATTACH. | 2"                | SNAP HOOK ATTACH. | 1650 | 390 | 750 | 200 | 700  | /   |
| <b>ONE 3+2 ENDUR.</b><br>DA0-0205-A02  | POLYESTER            | 6      | ULTRA LIGHT | DOWN       | ONLY     | 2"                  | SNAP HOOK ATTACH.           | 2"             | SNAP HOOK ATTACH. | 2"                | SNAP HOOK ATTACH. | 1650 | 390 | 750 | /   | 750  | /   |
| <b>TECNICA 3</b><br>DA0-0203-A01   | POLYESTER            | 6      | LIGHT       | UP         | FRIENDLY | 3"                  | SNAP HOOK ATTACH.           | 3"             | CARABINER ATTACH. | 2"                | SNAP HOOK ATTACH. | 1800 | 450 | 750 | 140 | 800  | /   |
| <b>TECNICA 3+2</b><br>DA0-0203-A02   | POLYESTER            | 6      | LIGHT       | UP         | ONLY     | 2"<br>3"            | ROLLBAR / SNAP HOOK ATTACH. | 3"             | CARABINER ATTACH. | 2"                | SNAP HOOK ATTACH. | 1800 | 450 | 700 | 140 | 800  | /   |
| <b>FIRST 3</b><br>DA0-0204-B01   | POLYESTER            | 6      | PROF.       | UP         | FRIENDLY | 3"                  | ROLLBAR / SNAP HOOK ATTACH. | 3"             | SNAP HOOK ATTACH. | 2"                | SNAP HOOK ATTACH. | 1800 | 450 | 700 | 140 | 800  | /   |
| <b>FIRST 3+2</b><br>DA0-0204-B02   | POLYESTER            | 6      | PROF.       | UP         | ONLY     | 2"<br>3"            | ROLLBAR / SNAP HOOK ATTACH. | 3"             | SNAP HOOK ATTACH. | 2"                | SNAP HOOK ATTACH. | 2200 | 390 | 700 | 140 | 800  | /   |
| <b>FIRST 2</b><br>DA0-0208-A01   | POLYESTER            | 6      | ULTRA LIGHT | DOWN       | ONLY     | 2"                  | SNAP HOOK ATTACH.           | 2"             | SNAP HOOK ATTACH. | 2"                | SNAP HOOK ATTACH. | 1650 | 450 | 750 | 170 | 700  | /   |

## FIA 8854 - 1998 SALOON

|                                   | MATERIAL  | POINTS | ADJUSTER | PULL | FHR      | SHOULDER BELT STRAP |                             | LAP BELT STRAP |                   | CROTCH BELT STRAP |                   | A    | B   | C   | D   | E | F |
|-----------------------------------|-----------|--------|----------|------|----------|---------------------|-----------------------------|----------------|-------------------|-------------------|-------------------|------|-----|-----|-----|---|---|
|                                   |           |        |          |      |          | 3"                  | ROLLBAR / SNAP HOOK ATTACH. | 3"             | SNAP HOOK ATTACH. | 3"                | SNAP HOOK ATTACH. |      |     |     |     |   |   |
| <b>FIRST 3 4P</b><br>DA0-0801-B01 | POLYESTER | 4      | PROF.    | UP   | FRIENDLY | 3"                  | ROLLBAR / SNAP HOOK ATTACH. | 3"             | SNAP HOOK ATTACH. | 3"                | SNAP HOOK ATTACH. | 1450 | 390 | 700 | 140 | / | / |

## FIA 8853 - 2016 FORMULA

|  | MATERIAL  | POINTS | ADJUSTER    | PULL | FHR  | SHOULDER BELT STRAP |                               | LAP BELT STRAP |               | CROTCH BELT STRAP |               | A   | B   | C   | D   | E   | F |
|--|-----------|--------|-------------|------|------|---------------------|-------------------------------|----------------|---------------|-------------------|---------------|-----|-----|-----|-----|-----|---|
|  |           |        |             |      |      | 2"                  | SEWN WEBB ATTACH.             | 2"             | PLATE ATTACH. | 2"                | PLATE ATTACH. |     |     |     |     |     |   |
| <b>ONE-D 2 PROT.</b><br>DA0-0102-A05   | DYNEEMA   | 6      | ULTRA LIGHT | UP   | ONLY | 2"                  | SEWN WEBB ATTACH.             | 2"             | PLATE ATTACH. | 2"                | PLATE ATTACH. | 400 | 390 | 700 | 125 | 850 | / |
| <b>ONE-D 2 FORM.</b><br>DA0-0104-A01   | DYNEEMA   | 6      | ULTRA LIGHT | /    | ONLY | 2"                  | SEWN WEBB ATTACH.             | 2"             | PLATE ATTACH. | 2"                | PLATE ATTACH. | 305 | 420 | 650 | /   | 750 | / |
| <b>TECNICA 2 FORM.</b><br>DA0-0206-A01<br><b>TECNICA 2 FORM.</b><br>DA0-0206-A02 | POLYESTER | 6      | ULTRA LIGHT | UP   | ONLY | 2"                  | PLATE / WEBB END SEWN ATTACH. | 2"             | PLATE ATTACH. | 2"                | PLATE ATTACH. | 320 | 500 | 725 | /   | 750 | / |

# ROAD 4

DAO-0505-B01 € 109,00 (A)

**Plate attachment**  
**Adjusters:** steel  
**Push button release:** central  
 Supplied with 7/16" bolts

Shoulder straps: 2"  
 Lap straps: 2"

**ECE R16-08**



DAO-0505-B01-061 red    DAO-0505-B01-041 blue



DAO-0505-B01-071 black



4 POINTS  
ECE R16-08

# ROAD 4M

DAO-0507-B01 € 119,00 (A)

**Snap hook attachment**  
**Adjusters:** steel  
**Push button release:** central  
 Supplied with 7/16" bolts

Shoulder straps: 2"  
 Lap straps: 2"

**ECE R16-08**



DAO-0507-B01-061 red    DAO-0507-B01-041 blue



DAO-0507-B01-071 black



4 POINTS  
ECE R16-08

# STRADA 3

DAO-0509-B01 € 115,00 (A)

3 POINTS  
ECE R16-08

**Plate attachment**  
**Adjusters:** steel  
**Push button release:** central  
 Supplied with 7/16" bolts

Shoulder straps: 2"  
 Lap straps: 2"

**ECE R16-08**



DAO-0504-B01-061 red



DAO-0504-B01-071 black



DAO-0504-B01-061 red



DAO-0504-B01-041 blue



DAO-0504-B01-071 black



# ROAD 3

DAO-0504-B01 € 109,00 (A)

3 POINTS  
ECE R16-08

**Plate attachment**  
**Adjusters:** steel  
**Push button release:** central  
 Supplied with 7/16" bolts

Shoulder straps: 2"  
 Lap straps: 2"

**ECE 16-18**

# RACING 4M

DAO-0508-B01 € 145,00 (A)

4 POINTS  
ECE R16-08

**Snap hook attachment.**  
**Adjusters:** steel.  
**Push button release:** central.  
 Supplied with 7/16" eye bolts.

Shoulder straps: 3"  
 Lap straps: 2"

**ECE R16-08**



DAO-0508-B01-061 red



DAO-0508-B01-041 blue



DAO-0508-B01-071 black



# SAFETY BELT ACCESSORIES

## SEAT BELT PADS 2"

DB0-0455 € 86,00 (A)

Pair of harness pads in fire retardant Nomex to be used with 2" seat belts. Zipper quick closure, antislip silicon rubber inserts in shoulders contact area. Compatible with Hybrid® safety device.



## CUTTER

DB0-0459 € 8,00 (C)

Safety seat belt cutter.



## CUTTER

DB0-0461 € 12,00 (C)

Safety seat belt cutter.



## EYEBOLT

DB0-0420-A01 € 5,50 (C)

7/16" eyebolt to attach harness snap-hook fittings.



A: 57 mm  
B: 15,5 mm  
C: 20 mm  
D: 7/16" UNF  
L: 22 mm  
S: 8 mm

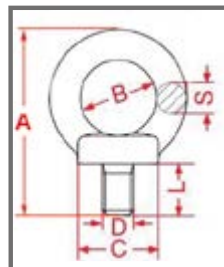

## SEAT BELT PADS 3"

DB0-0450-A02 € 36,00 (A)

Yellow OMP logo. In velour, use with 3" seat belts. Clousure: velcro.



DB0-0450-A02-041  
blue



DB0-0450-A02-071  
red



DB0-0450-A02-071  
black



## SEAT BELT PADS 2"

DB0-0450-A01 € 23,00 (A)

Yellow OMP logo. In velour, use with 2" seat belts. Clousure: velcro.



DB0-0450-A01-041  
blue



DB0-0450-A01-071  
red



DB0-0450-A01-071  
black



## HANS STRAP BOLDER

SC0-0020 € 15,00 (C)

Hands strap bolder in rubber (pair), with sticker



## SEAT BELT PLATE

DB0-0418-A01 € 8,50 (C)

Seat belt plate with threaded 7/16" nut. DIMENSIONS: 50x80x3 mm

FIA APPENDIX J art. 253

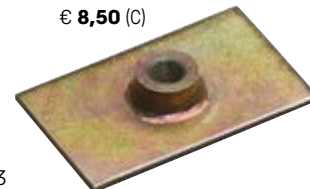

## PLATE FOR EYEBOLTS

DB0-0421-A01 € 4,00 (C)

Reinforced threaded plate for eyebolts.

DIMENSIONS: 50x25x6 mm



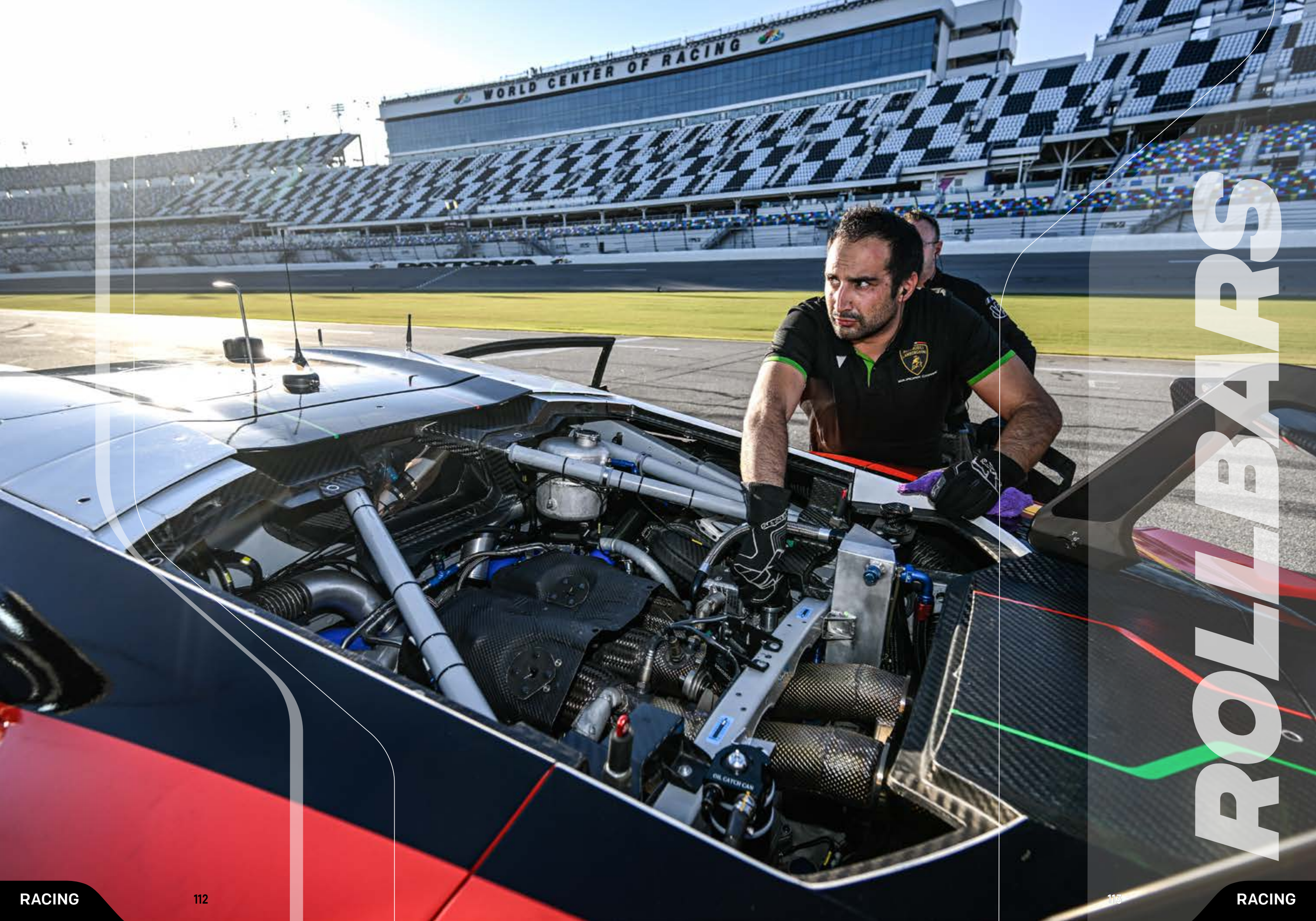

WORLD CENTER OF RACING

# ROLL-ON BARBERS

# ROLL BARS

## FE 45 BOLT-IN

ABO-0100-...



FE45 steel bolt-in rollbars with Ø 40x2 & 50x2 tubing, connecting sleeve tubes and reinforced brace in the main hoop. Supplied with door bars and diagonal reinforcement at rear.

## FE 45 BOLT-IN

AAO-104P-...



FE45 steel bolt-in rollbars with door bars to be cut to measure and welded upon installation.

## FE 45 BOLT-IN

ABO-105P-...



FE45 steel multi-point bolt-in rollbars with Ø 40x2 & 50x2 tubing, connecting sleeve tubes and door bars. To be cut to measure and welded upon installation.

## FE 45 WELD-IN

ABO-0105-...A

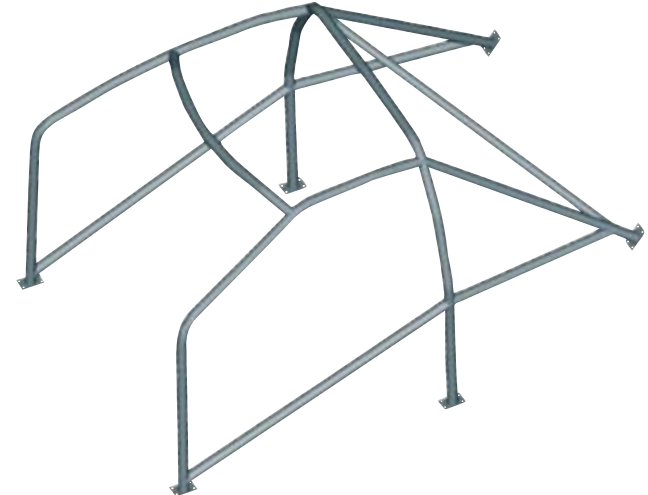

FE45 steel weld-in rollbars with Ø 50x2 tubing on the main hoop and Ø 40x2 tubing elsewhere. It may be necessary to remove or cut interior panels to facilitate installation.

**ROLLBARS NOT DISTRIBUTED IN THE US**

The photo representing each type of rollbar is for illustrative purposes only. Please refer to our application list on [www.ompracing.com](http://www.ompracing.com) to verify the real structure of the rollbars.



## MULTI-POINT WELD-IN

ABO-0106-...A ABO-0106-...AW

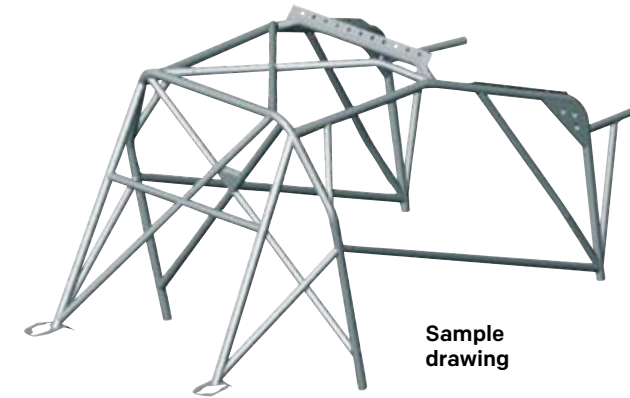

AB/106/...A supplied partially assembled.  
AB/106/...AW supplied not assembled.  
Multi-point weld-in chromoly (25CrMo4) rollbars. Reduced weight and improved rigidity compared with steel bolt-in rollbars. Supplied partially assembled to facilitate and reduce installation cost.

## MULTI-POINT WELD-IN

ABO-0106-...B

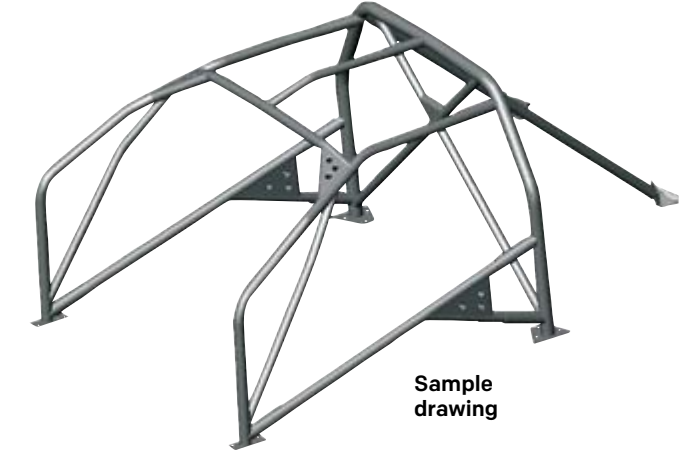

Multi-point bolt-in chromoly (25CrMo4) rollbars. Reduced weight and improved torsional rigidity.

## OFF ROAD BOLT-IN

R/...

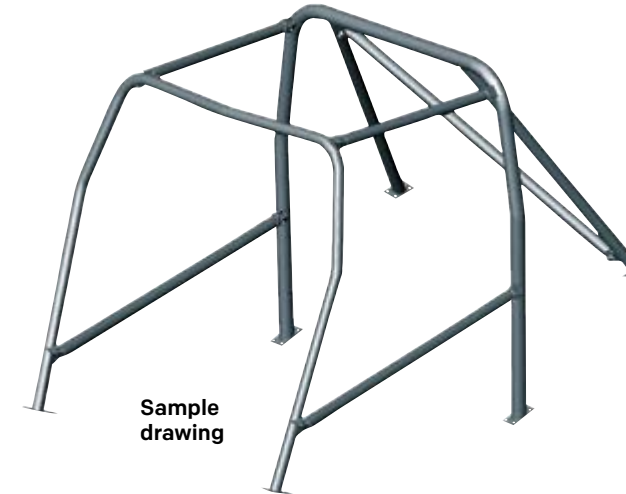

FE45 steel multi-point bolt-in rollbars with Ø 40x2 & 50x2 tubing, connecting sleeve tubes and door bars. To be cut to measure and welded upon installation.

## REPLACEMENT HOOD

AAO-0103... ABO-0107... AAO-0102... ABO-0108...

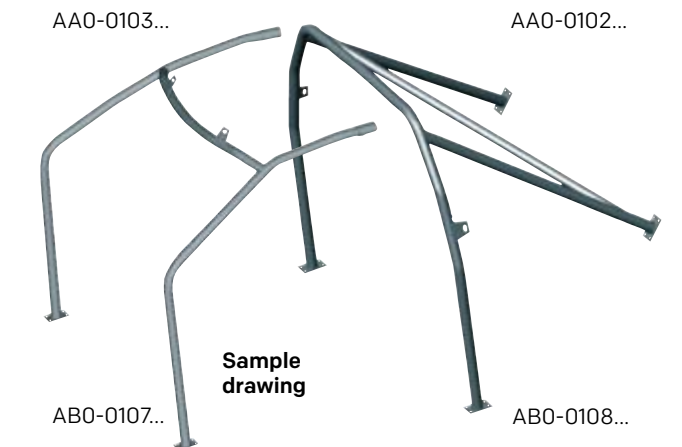

FE45 steel weld-in rollbars with Ø 50x2 tubing on the main hoop and Ø 40x2 tubing elsewhere. It may be necessary to remove or cut interior panels to facilitate installation.

**ROLLBARS NOT DISTRIBUTED IN THE US**

# RACING ROLLBARS PARTS AND ACCESSORIES

## RUBBER SLEEVING

AAO-0113

Foamed rubber sleeving for rollbar sold in pieces of 2 m.

AAO-0113-C01  
Ø 40mm

€ 27,00 (C)

AAO-0113-D01  
Ø 50mm

€ 37,00 (C)



## CONNECTION

AAO-0122

Connection for rollbar, complete with hardware.

AAO-0122-A01  
with tube Ø 40 mm  
€ 22,50 (C)

AAO-0122-B01  
with tube Ø 50 mm  
€ 20,50 (C)



FIA-J ALL

## PLATE

AAO-0175-C01 € 12,00 (C)

Flat plate lower reinforcement for standard rollbars. **Dimensions:** 100x120x3 mm



FIA-J ALL

## CONNECTING TUBE

AAO-0195 € 20,00 (C)

Sleeve connecting tube in FE 45 steel for tubing Ø 40 mm

FIA-J ALL



## CONNECTING TUBE

AAO-0108 € 85,00 (C)

Pair of door bars FE 45 steel, to be welded (no picture). **Length:** 1.20 m - **Thickness:** 2 mm - Ø 40 mm



AAO-0109 € 121,00 (C)

Pair of door bars FE 45 steel, complete with connections. **Length:** 1.25 m - **Thickness:** 2 mm 40 mm

## REINFORCEMENT

AAO-0200 € 20,50 (C)

Reinforce rollbar crosses. **Thickness:** 1,5 mm **Gusset:** 80°

FIA-J ALL  
DIS 253-24



## ENERGY ABSORBING

AAO-0116 € 27,00 (C)

Rollbar padding Molded energy absorbing rollbar padding suitable. **Length:** 490mm. For tube Ø 30/40 mm

TYPE A



MANUFACTURER: OMP  
MODEL: AAO-0116  
HOM. NO: CP010.24.A  
FIA STANDARD: FIA 8857-2001



## ENERGY ABSORBING

AAO-0115 € 27,00 (C)

Molded energy absorbing rollbar padding suitable for both. **Length:** 490 mm For tube Ø 40/50 mm

TYPE A



MANUFACTURER: OMP  
MODEL: AA115A  
HOM. NO: CP007.06.A  
FIA STANDARD: FIA 8857-2001

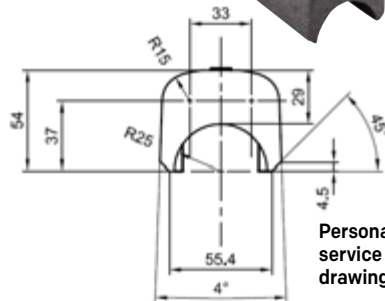

Personalized protection kit service based on customers' drawing.

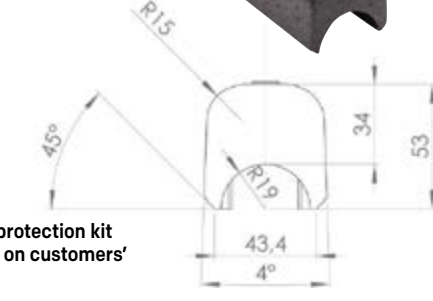

# RACING ROLLBARS PARTS AND ACCESSORIES

## REINFORCEMENT

AAO-0111-A01 € 299,00 (C)

Pair assembled cross door reinforcement, connections included.



## REINFORCEMENT

AAO-0111-B01 € 229,00 (C)

Pair not assembled cross door reinforcement, connections included. Ø 40x2 mm

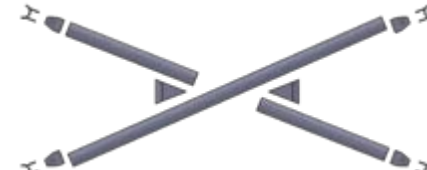

## REINFORCEMENT

AAO-0111-C01 € 279,00 (C)

Pair not assembled cross door reinforcement, connections included. Ø 40x2 mm



FIA-J ALL

## REINFORCEMENT

AAO-0204 € 129,00 (C)

Pair of door reinforcements in FE45. Supplied with connecting sleeves. Nuts and bolts included. **Length:** 1.25 m Ø 40x2 mm

FIA-J ALL



## REINFORCEMENT

AAO-0175-A01 € 14,00 (C)

Universal "L" shaped reinforcement plate. Adjustable and suitable for any standard steel rollbar. **Thickness:** 3 mm

FIA-J ALL



## REINFORCEMENT

AAO-0203 € 32,00 (C)

Kit (2+2) of perforated plates for rollbar fixing in.

FIA-J ALL

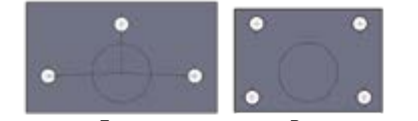

Front

Rear

## COVERS 50 CM

AAO-0113-B01 € 59,00 (C)

Pair of door bar covers in velour material (same as competition seats) to cover rubber sleeving.



## REINFORCEMENT

AAO-0202 € 150,00 (C)

Pair assembled cross door reinforcement, connections included. Ø 40x2 mm

FIA-J ALL



## REINFORCEMENT

AAO-0123 € 11,30 (C)

Reinforcement to be used with connections AA/122 and AA/122-50.

FIA-J ALL



## REINFORCEMENT

AAO-0201 € 19,00 (C)

Reinforce rollbar crosses. **Thickness:** 1,5 mm **Gusset:** 100°

FIA-J ALL  
DIS 253-24



## COVERS 100 CM

AAO-0113-A01 € 69,00 (C)

Pair of door bar covers in velour material (same as competition seats) to cover rubber sleeving.





# EXTINGUISHERS

# CEFAL4

CEO-FAL4-A01 € 1.490,00 (C)

MADE IN ITALY

## SERIE 4

- Homologated to FIA 8876-2022, the latest and most advanced FIA standard for plumbed-in fire suppression systems for open cockpit cars
- Covers a wide range of fuels, from petrol to E85 (CLASS I, II, and V)
- The extinguishing medium is:
  - Non-corrosive
  - Not electrically conductive
  - Residue-free (unlike foam or powder, it leaves no damage and requires no cleaning after discharge)
- The system becomes pressurized upon activation, allowing the extinguishant to discharge effectively
- Electrical system is waterproof and ready for installation
- ECU certified IP65 and IP67 for protection against dust and water

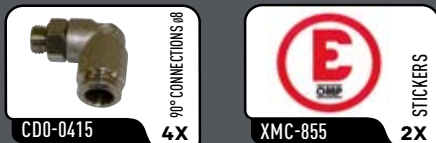

MANUFACTURER: OMP  
MODEL: CEFAL4  
HOM. NO: FS.003.24  
FIA STANDARD: 8876 - 2022

Homologated for use on:  
Petrol - class I  
Petrol + up to 30% ethanol or methanol (E30) - class II  
Petrol + up to 85% ethanol or methanol (E85) - class V



**FORMULA**  
**ULTRALIGHT**  
**Ø 110 MM**  
**SUITABLE FOR ELECTRIC AND HYBRID CARS**

### ONE COLLECTION FIA 8876-2022 - CEFAL4

| Ref.         | Extinguishant  | Empty (kg) | Total weight* |
|--------------|----------------|------------|---------------|
| CEO-FAL4-A01 | 2 kg FK-5-1-12 | 1.2        | 3.2 kg        |

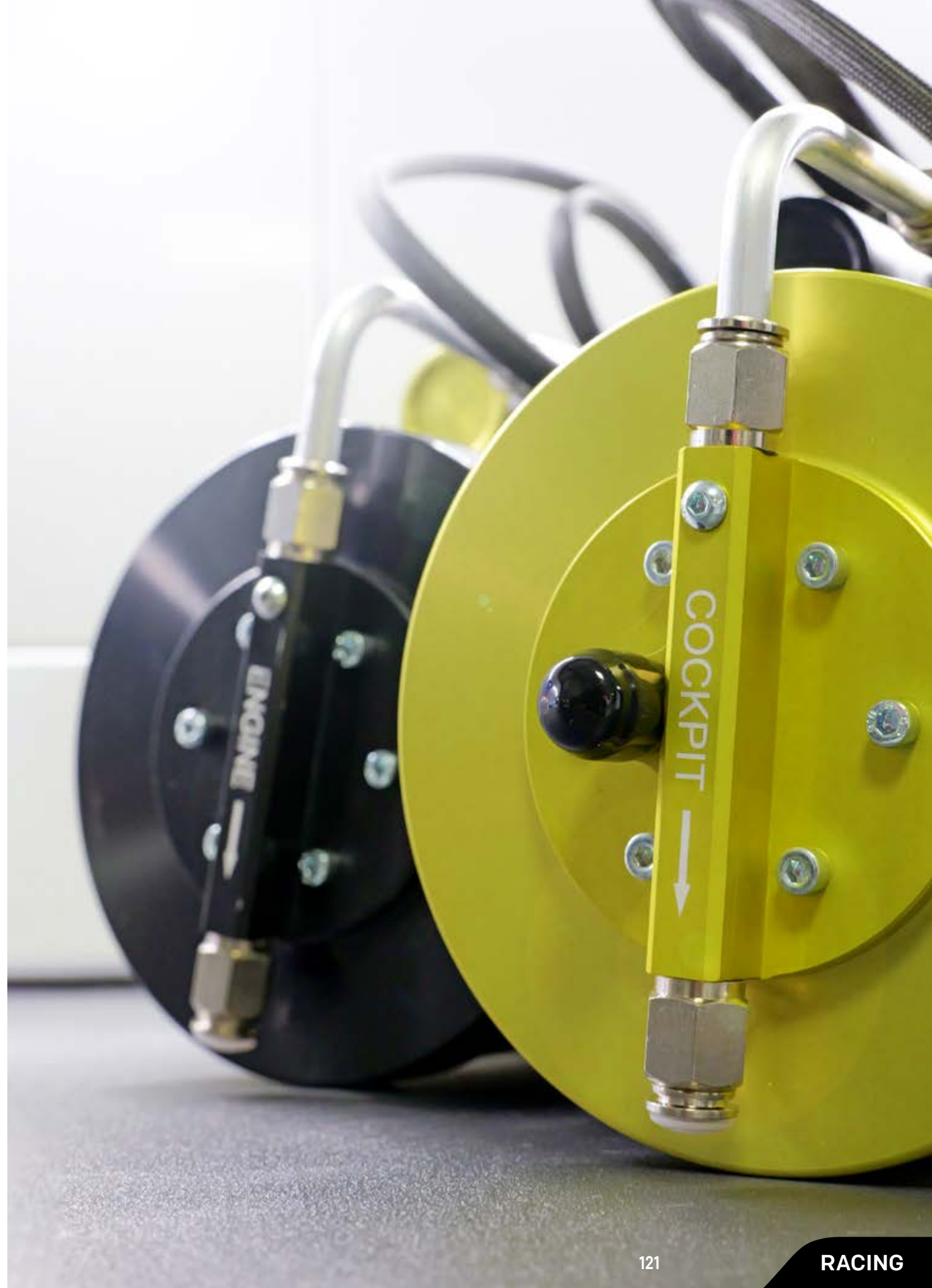
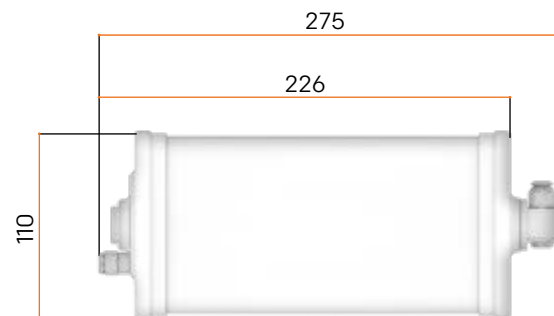

# CLASSIC CONTROL UNIT

## BACK PANNEL MOUNTING

CD0-0380-A01 ON REQUEST



ELECTRONIC CONTROL UNIT FOR FIA 8865-2015 AND FIA 8876-2022 FIRE EXTINGUISHER SYSTEMS AND SERIE 6 TL 16

- ECU with switch & LEDs on the top cover of the ECU
- Two-ways cable to connect activation buttons and bottle to the ECU
- Waterproof dedicated cables and connectors
- Customizable cable extensions
- Internal/External activation buttons
- Possibility to add extra activation buttons
- Easy battery replacement
- IP65 certified

TWO EXT. ACTIVATION BUTTON CONFIGURATION — OPTIONAL

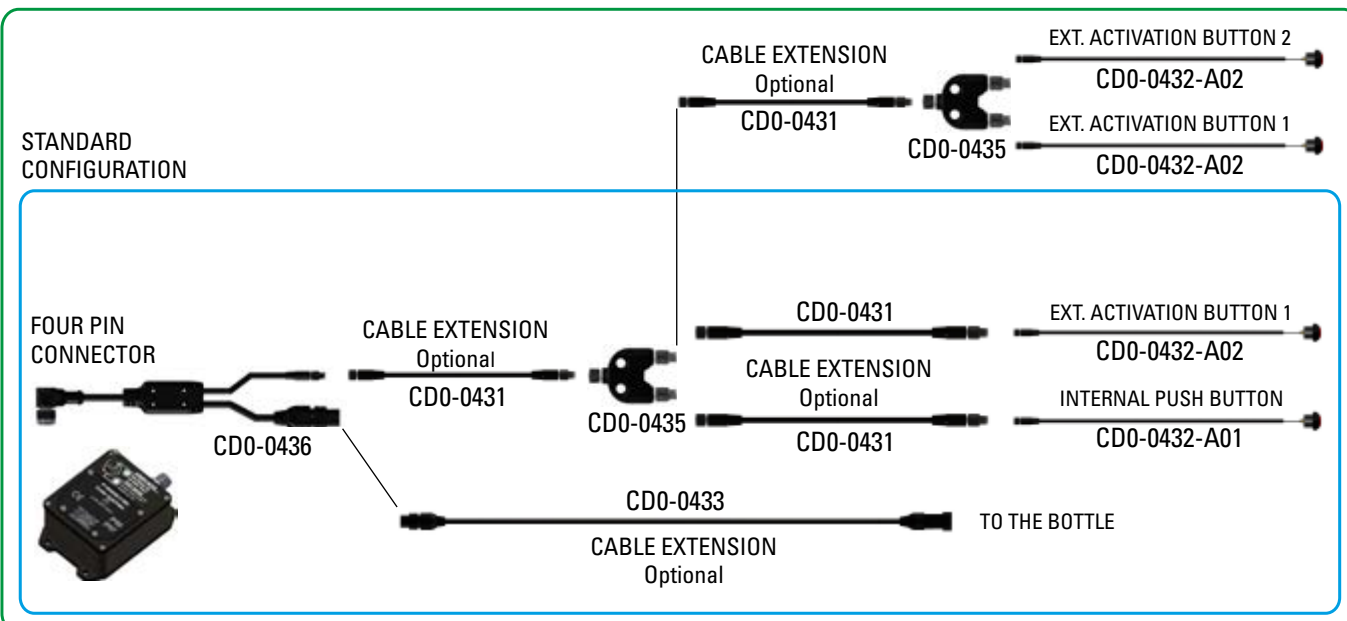

## FRONT PANNEL MOUNTING

CD0-0380-A05 ON REQUEST

Also available on request with front mounting panel.



## WITH CANBUS CONNECTION

CD0-0380-A03 ON REQUEST

CANBUS version upon request to connect the ECU to the CANBUS line of the car.



## FRONT PANNEL MOUNTING AND CANBUS CONNECTION

CD0-0380-A07 ON REQUEST

Also available on request with CANBUS version and front mounting panel.



# REMOTE CONTROL UNIT

## FRONT PANNEL MOUNTING

CD0-0380-A06 ON REQUEST

Also available on request with front mounting panel.



## WITH CANBUS CONNECTION

CD0-0380-A04 ON REQUEST

CANBUS version upon request to connect the ECU to the CANBUS line of the car.



## FRONT PANNEL MOUNTING AND CANBUS CONNECTION

CD0-0380-A08 ON REQUEST

Also available on request with CANBUS version and front mounting panel.



## BACK PANNEL MOUNTING

CD0-0380-A02 ON REQUEST



ELECTRONIC CONTROL UNIT FOR FIA 8865-2015 AND FIA 8876-2022 FIRE EXTINGUISHER SYSTEMS AND SERIE 6 TL 16

- Test/Armed Switch & LEDs on a dedicated panel that can be placed everywhere in the cockpit
- Three-ways cable to connect switch & LEDs, activation buttons and bottle to the ECU
- Optimal solution for small cockpit
- Possibility to add extra activation button
- Easy battery replacement
- Customizable cable extensions
- IP65 certified

TWO EXT. ACTIVATION BUTTON CONFIGURATION

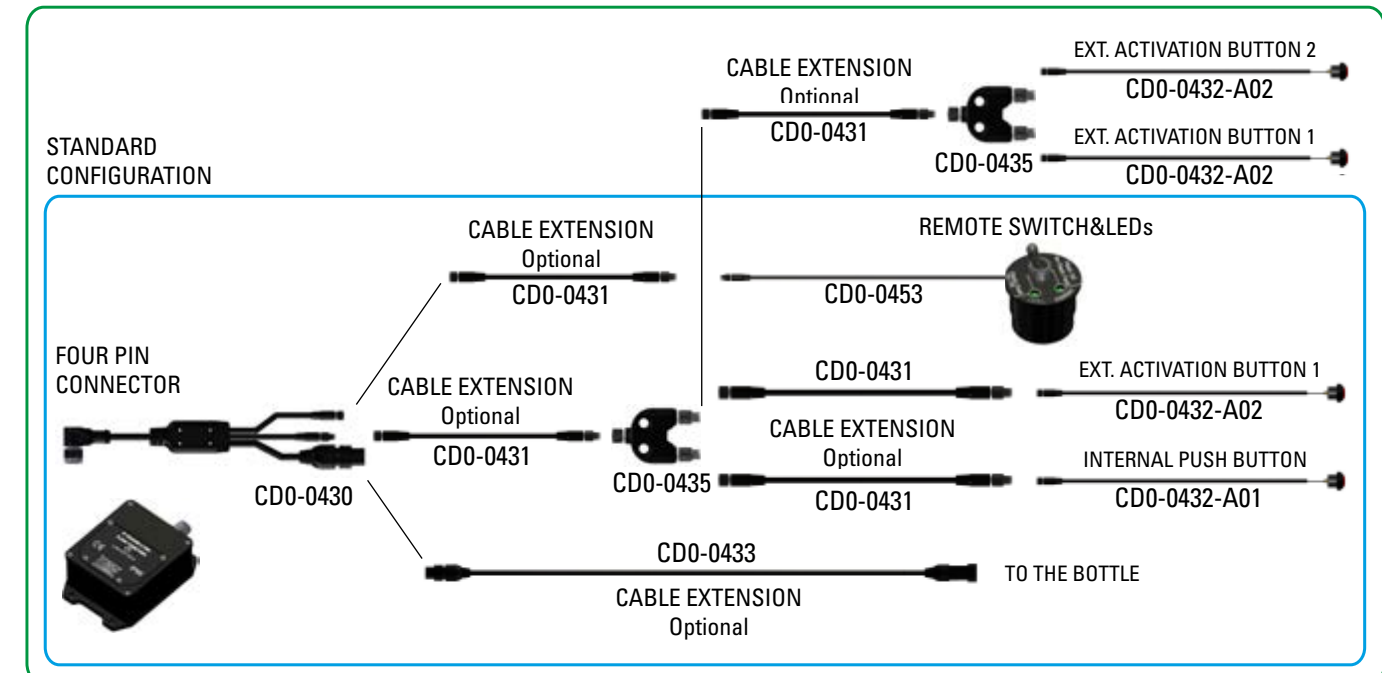

# CESAL4 LE

CEO-SAL4-D01 € 2.650,00 (C)

"L" VERSION SUITABLE FOR LARGE SIZED COCKPIT (FROM 2.2 m<sup>3</sup> UP TO 4.1 m<sup>3</sup>)

- Compact and lightweight fire extinguisher system
- Electrically activated, suitable for saloon cars
- Complies with FIA 8865-2015 regulations
- System pressurizes upon activation to discharge the extinguishant
- 3 nozzles for the engine bay to protect the most critical areas
- 2 nozzles for the cockpit to ensure driver front and rear protection
- Includes fixing brackets, clamps, tubing, and connections
- Suitable for electric and hybrid cars

Homologated for use on:  
- Homologated for use on: petrol, petrol + up to 30% ethanol or methanol



MANUFACTURER: OMP  
MODEL: CESAL4LE  
HOM. NO: EX.03725  
FIA STANDARD: FIA 8865-2015

MADE IN ITALY



**NEW**

# CESAL4 SE

CEO-SAL4-F01 € 2.650,00 (C)

Same characteristics as CEO-SAL4-D01, but "S" version suitable for small sized cockpit (from 1.2 m<sup>3</sup> up to 2.2 m<sup>3</sup>).



MANUFACTURER: OMP  
MODEL: CESAL4SE  
HOM. NO: EX.03825  
FIA STANDARD: FIA 8865-2015

MADE IN ITALY



**NEW**

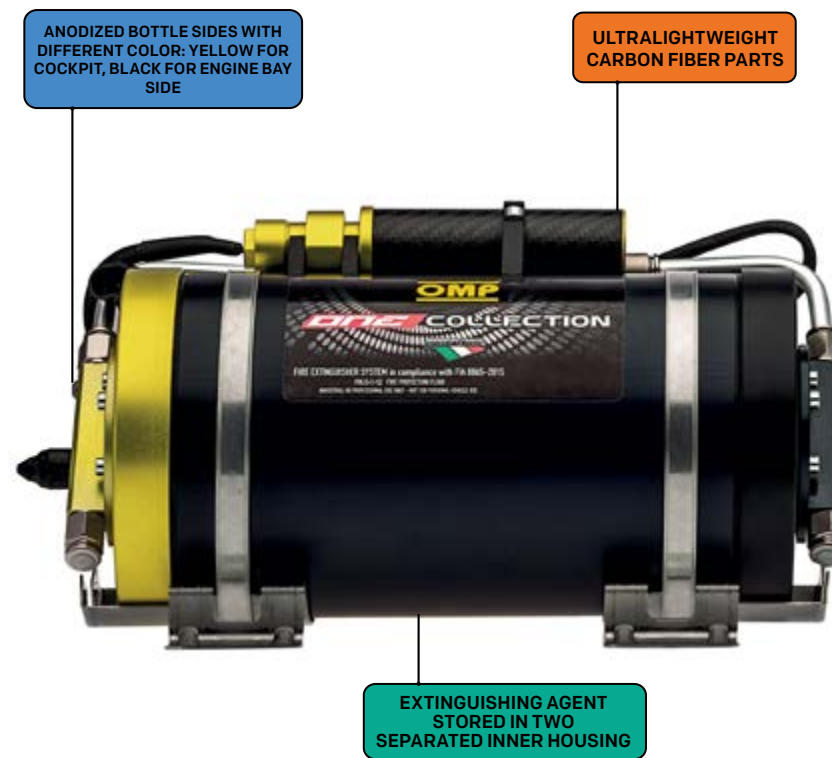

ONE COLLECTION FIA 8865-2015 - CESAL4LE

| Ref.         | Extinguishant                      | Total weight* |
|--------------|------------------------------------|---------------|
| CEO-SAL4-D01 | 2.7 kg FK-5-1-12<br>1 kg FK-5-1-12 | 5.5 kg        |

ONE COLLECTION FIA 8865-2015 - CESAL4SE

| Ref.         | Extinguishant                        | Total weight* |
|--------------|--------------------------------------|---------------|
| CEO-SAL4-F01 | 1.5 kg FK-5-1-12<br>2.2 kg FK-5-1-12 | 5.5 kg        |

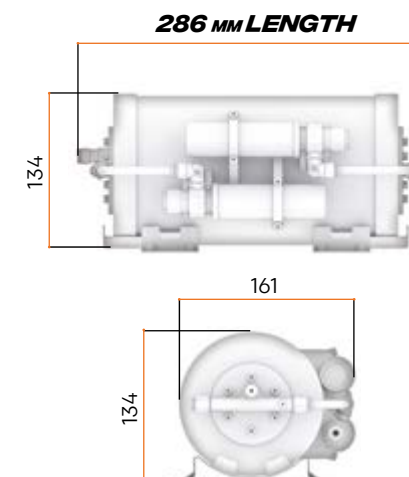
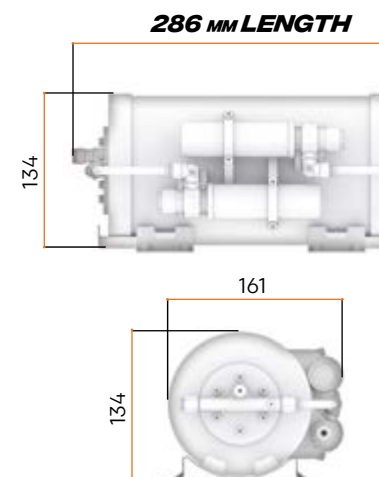

MEASUREMENTS IN MM

## SALOON ULTRALIGHTWEIGHT Ø 130 MM

Fire Extinguishing System in compliance with FIA 8865-2015

Designed for use with FK-5-1-12 Fire Protection fluid.

-  CDO-0415 **5X**
-  CDO-0414 **2X**
-  CDO-0412 **1X**
-  CDO-0416 **6X**
-  CDO-0324-A01 **2X**
-  CDO-0323-A01 **2X**
-  CDO-0431 **1X**
-  CDO-0454 **3X**
-  CDO-0432-A01 **1X**
-  CDO-0441 **2X**
-  CDO-0435 **1X**
-  CDO-0410 **2X**
-  XMC-855 **2X**
-  CDO-0380-A01 **1X**
-  CDO-0408 **2X**
-  CDO-0409 **2X**

# CESAL5LE

CEO-SAL5-D01 € 1.690,00 (C)

"L" VERSION SUITABLE FOR LARGE SIZED COCKPIT (FROM 2.2 m3 UP TO 4.1 m3)

- Full FK-5-1-12 extinguishing system, electrically activated, suitable for both electric and petrol cars
- Two nozzles for cockpit
- Two nozzles for engine bay
- One nozzle for extra position / inverters (not to be used inside the cockpit)
- New control unit with dedicated low-battery alarm
- Fixing brackets, clamps, piping and connections included
- Suitable for electric and hybrid cars

Homologated for use on:  
Petrol - Electric/Hybrid cars (class I)

MADE IN ITALY



MANUFACTURER: OMP  
MODEL: CESAL5E  
HOM. NO: EX.025.21  
FIA STANDARD: FIA 8865-2015

# CESAL5SE

CEO-SAL5-C01 € 1.690,00 (C)

Same characteristics as CEO-SAL5-D01, but "S" version suitable for small sized cockpit (from 1.35 m3 up to 2.5 m3).

MADE IN ITALY



MANUFACTURER: OMP  
MODEL: CESAL5S  
HOM. NO: EX.026.21  
FIA STANDARD: FIA 8865-2015

## SALOON LIGHTWEIGHT Ø 160 MM

Fire Extinguishing System in compliance with FIA 8865-2015

Designed for use with FK-5-1-12 Fire Protection fluid.

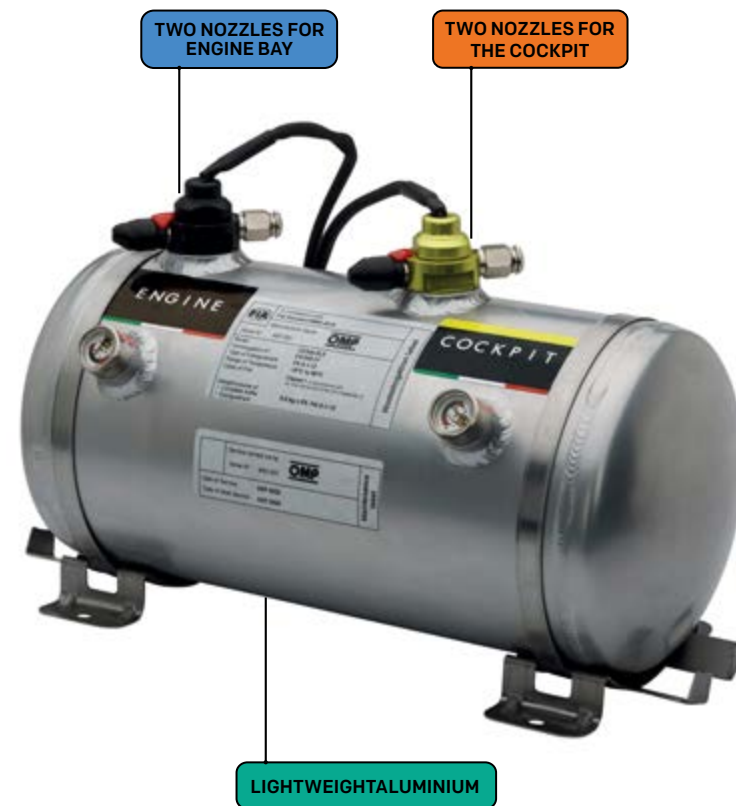

### TECNICA COLLECTION FIA 8865-2015 - CESAL5LE

| Ref.         | Extinguishant    | Total weight* |
|--------------|------------------|---------------|
| CEO-SAL5-D01 | 2.7 kg FK-5-1-12 | 6.5 kg        |
|              | 1.7 kg FK-5-1-12 |               |

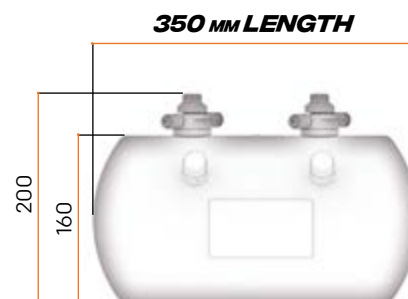

### TECNICA COLLECTION FIA 8865-2015 - CESAL5SE

| Ref.         | Extinguishant    | Total weight* |
|--------------|------------------|---------------|
| CEO-SAL5-C01 | 1.7 kg FK-5-1-12 | 6.5 kg        |
|              | 1.7 kg FK-5-1-12 |               |



MEASUREMENTS IN MM

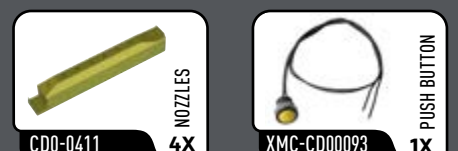
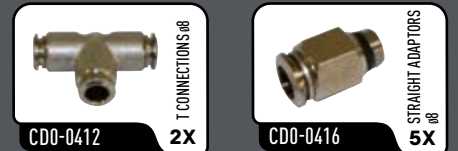

# CESAL5 DOUBLE BOTTLE



MANUFACTURER: OMP  
MODEL: CESAL5L  
HOM. NO: EX.022.19  
FIA STANDARD: FIA 8865-2015

**SALOON**  
**DOBLE BOTTLE**  
**Ø 160 MM**  
**SUITABLE FOR T5 DIESEL**  
**VEHICLE**

CEO-SAL5-E01 € 3.500,00 (C)

MADE IN ITALY

## SERIE 5

- In some categories, two FIA 8865-2015 fire extinguisher systems are required (i.e. T1, T5, etc.)
- CEO-SAL5-E01 is a double system suitable where two systems are needed, or for volumes between 4.4 and 8.2 m<sup>3</sup>
- Other customized systems for specific needs are available on request
- For any inquiry, including retrofit of single-bottle systems, contact Racing Force or an authorized dealer
- Available upon request

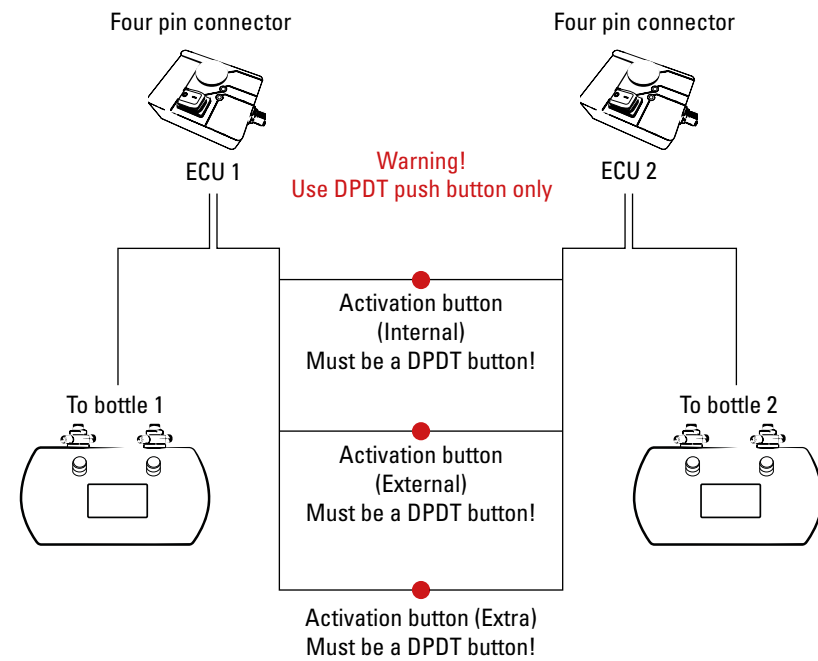

### TECNICA COLLECTION FIA 8865-2015 - CESAL5

| Ref.         | Extinguishant                   | Total weight* |
|--------------|---------------------------------|---------------|
| CEO-SAL5-A01 | 2.7 kg FK-5-1-12<br>1.2 lt AFFF | 6 kg          |

### TECNICA COLLECTION FIA 8865-2015 - CESAL5

| Ref.         | Extinguishant                   | Total weight* |
|--------------|---------------------------------|---------------|
| CEO-SAL5-A01 | 2.7 kg FK-5-1-12<br>1.2 lt AFFF | 6 kg          |

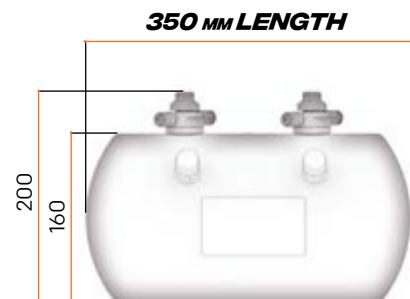
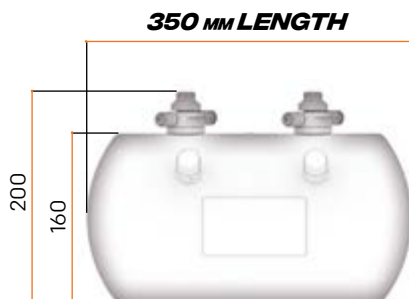

MEASUREMENTS IN MM

- CD0-0415 6X 90° CONNECTIONS Ø8
- CD0-0414 4X Y CONNECTIONS Ø8
- CD0-0412 2X T CONNECTIONS Ø8
- CD0-0416 4X STRAIGHT ADAPTORS Ø8
- CD0-0324-A01 4X 5m SHEATH Ø10
- CD0-0323-A01 6X 4M AL PIPING Ø8
- CD0-0393-A02 6X ENGINE BAY NOZZLES
- XMC-CD367 1X DPDT PUSH BUTTON
- XMC-855 2X STICKERS
- CD0-0410 4X NOZZLES
- XMC-CAB-360E 1X WIRING
- CD0-0360 1X CONTROL BOX



# CEFAL6

CEO-FAL6-A01 € 699,00 (C)

## SERIE 6

- Electrically activated fire extinguishing system engineered for single-seater cars requiring a compact and high-performance fire suppression system
  - CEFAL6 system uses FK-5-1-12 clean agent
  - Lightweight 100 mm aluminium bottle for fluid storage
  - Delivers high fire suppression performance through precision-engineered nozzle and tubing layout
  - Designed for installations where space and weight are critical
- Control unit, fixing brackets, clamps, piping and connections included
- Suitable for electric and hybrid cars

MADE IN ITALY

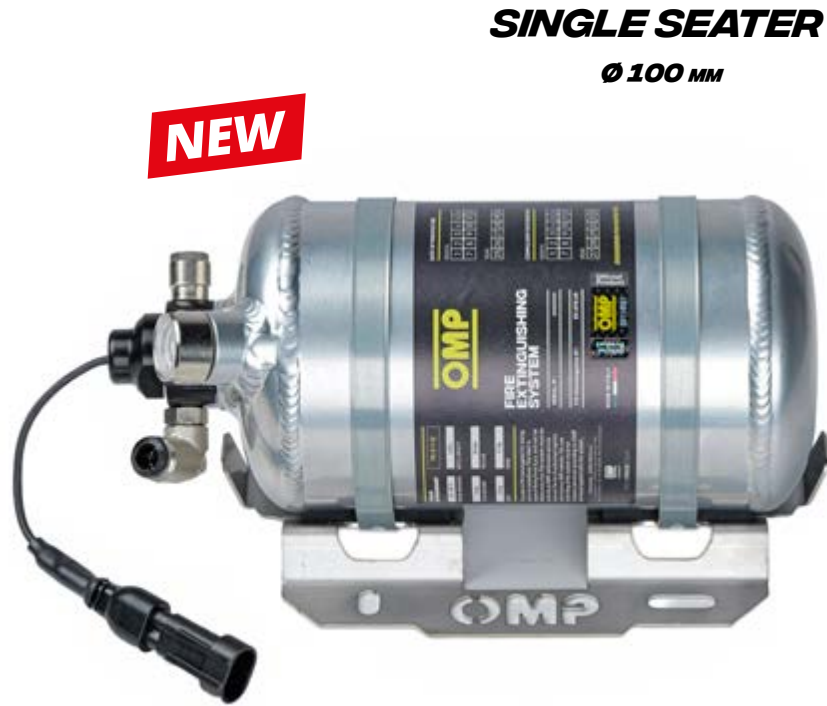

**SINGLE SEATER**  
Ø 100 MM

**NEW**



MANUFACTURER: OMP  
MODEL: SERIES 6 SINGLE SEATER  
HOM. NO: EX.070.25  
FIA STANDARD: TECH. LIST 16

# CMFAL6

CM0-FAL6-A01 € 520,00 (C)

Same features as CEO-FAL6-A01 but MANUAL VERSION.

- Manually activated
- Aluminium mechanical valve

MADE IN ITALY



**SINGLE SEATER**  
Ø 100 MM

**NEW**



MANUFACTURER: OMP  
MODEL: SERIES 6 SINGLE SEATER  
HOM. NO: EX.070.25  
FIA STANDARD: TECH. LIST 16



### TECH. LIST 16 - CEFAL6

| Ref.         | Extinguishant    | Total weight* |
|--------------|------------------|---------------|
| CEO-FAL6-A01 | 1.4 kg FK-5-1-12 | 2.05kg ±5%    |

### TECH. LIST 16 - CMFAL6

| Ref.         | Extinguishant    | Total weight* |
|--------------|------------------|---------------|
| CM0-FAL6-A01 | 1.4 kg FK-5-1-12 | 2.2kg ±5%     |

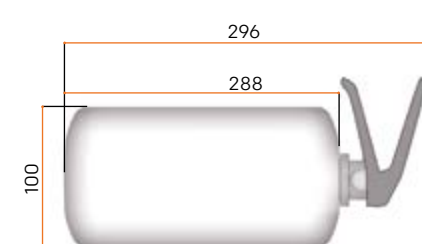
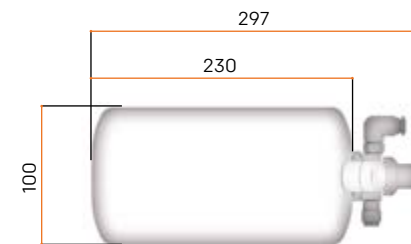

MEASUREMENTS IN MM

## COMMON PARTS



## ELECTRIC FIRE EXTINGUISHER COMPONENTS



## MANUAL FIRE EXTINGUISHER COMPONENTS



# CESAL6 2KG

CEO-SAL6-A01 € 780,00 (C)

## SERIE 6

- Electrically activated fire extinguishing system engineered for saloon cars requiring a compact and high-performance fire suppression solution
- CESAL6 2KG system uses FK-5-1-12 clean agent
- Fluid stored in a lightweight 130 mm aluminium bottle
- Delivers optimal fire suppression performance through a precision-engineered nozzle and tubing layout
- Designed to maximize efficiency where space and weight are critical
- Control unit, fixing brackets, clamps, piping, and connections included
- Suitable for electric and hybrid cars

MADE IN ITALY

**FIA APPROVED**

MANUFACTURER: OMP  
MODEL: SERIES 6 SALOON 2KG  
HOM. NO: EX.071.25  
FIA STANDARD: TECH. LIST 16



**SALOON**  
Ø 130 MM

# CESAL6 3KG

CEO-SAL6-C01 € 850,00 (C)

Same features as CEO-SAL6-C01 but with 160mm bottle and 3 kg extinguishant.

MADE IN ITALY

**FIA APPROVED**

MANUFACTURER: OMP  
MODEL: SERIES 6 SALOON 3KG  
HOM. NO: EX.071.25  
FIA STANDARD: TECH. LIST 16



**SALOON/RALLY**  
Ø 160 MM



**SERIE 6 SALOON TECH. LIST 16 - CESAL6 2 kg**

| Ref.         | Extinguishant  | Total weight* |
|--------------|----------------|---------------|
| CEO-SAL6-A01 | 2 kg FK-5-1-12 | 2.85kg ±5%    |

**SERIE 6 SALOON TECH. LIST 16 - CESAL6 3 kg**

| Ref.         | Extinguishant  | Total weight* |
|--------------|----------------|---------------|
| CEO-SAL6-C01 | 3 kg FK-5-1-12 | 3.95kg ±5%    |

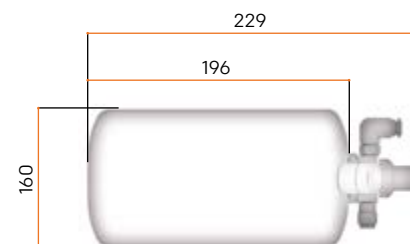
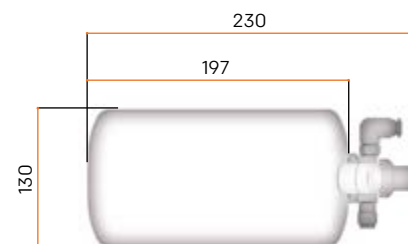

MEASUREMENTS IN MM

## SALOON

ULTRALIGHTWEIGHT  
Ø 130 / 160 MM

-  T CONNECTIONS ø8  
CDO-0392-A02 3X
-  T CONNECTIONS ø6  
CDO-0392-A03 1X
-  T CONNECTIONS ø8  
CDO-0390-B01 2X
-  T CONNECTIONS ø6  
CDO-0399 1X
-  90° CONNECTIONS ø8  
CDO-0391-A02 2X
-  90° CONNECTIONS ø6  
CDO-0391-A03 1X
-  STICKERS  
XMC-855 2X
-  BRACKETS  
CDO-0561 1X
-  4m AL PIPING ø6  
CDO-0323-A03 1X
-  4m AL PIPING ø8  
CDO-0323-A01 2X
-  5m SHEATH ø10  
CDO-0324-A01 2X
-  5m SHEATH ø8  
CDO-0324-A03 1X
-  CONTROL UNIT WIRING  
XMC-398-CAV 1X
-  CONTROL BOX  
CDO-0398 1X
-  BUTTON PROTECTION  
XMC-CD00094 1X
-  PUSH BUTTON  
XMC-CD00093 1X
-  ELECTRIC VALVE WIRING  
XMC-363-E-CAV 1X
-  ATOMIZER NOZZLES  
CDO-0393-A02 7X

# CMSAL6 2KG

CM0-SAL6-A01 € 620,00 (C)

## SERIES 6

- Manually activated fire extinguishing system engineered for saloon cars requiring a compact and high-performance fire suppression solution
- CMSAL6 2KG system uses FK-5-1-12 clean agent
- Fluid stored in a lightweight 130 mm aluminium bottle
- Features a precision-engineered nozzle and tubing layout to maximize fire suppression performance
- Equipped with an aluminium mechanical valve
- Designed for installations where space and weight are critical
- Fixing brackets, clamps, tubing, and connections included
- Suitable for electric and hybrid cars

MADE IN ITALY

**FIA APPROVED**

MANUFACTURER: OMP  
MODEL: SERIES 6 SALOON 2KG  
HOM. NO: EX.071.25  
FIA STANDARD: TECH. LIST 16

**NEW**

## SALOON Ø 130 MM



MANUALLY ACTIVATED WITH ALUMINIUM VALVE

ALUMINIUM BOTTLE



FK-5-1-12 CLEAN AGENT AVAILABLE IN 2KG OR 3KG VERSION

# CMSAL6 3KG

CM0-SAL6-B01 € 690,00 (C)

Same features as CM0-SAL6-C01 but with 160mm bottle and 3 kg extinguishant.

MADE IN ITALY

**FIA APPROVED**

MANUFACTURER: OMP  
MODEL: SERIES 6 SALOON 3KG  
HOM. NO: EX.071.25  
FIA STANDARD: TECH. LIST 16

**NEW**

## SALOON/RALLY Ø 160 MM



### SERIE 6 SALOON TECH. LIST 16 - CMSAL6 2KG

| Ref.         | Extinguishant  | Total weight* |
|--------------|----------------|---------------|
| CM0-SAL6-A01 | 2 kg FK-5-1-12 | 2.95 kg ±5%   |

### SERIE 6 SALOON TECH. LIST 16 - CMSAL6 3KG

| Ref.         | Extinguishant  | Total weight* |
|--------------|----------------|---------------|
| CM0-SAL6-B01 | 3 kg FK-5-1-12 | 4.1 kg ±5%    |

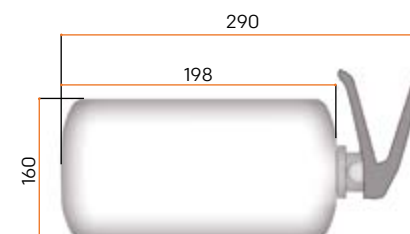
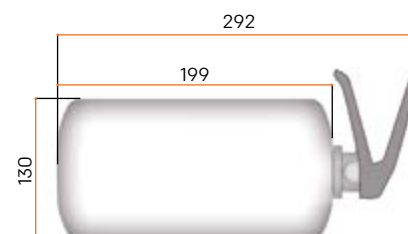

MEASUREMENTS IN MM

## SALOON ULTRALIGHTWEIGHT Ø 130 / 160 MM

- CD0-0392-A02 3X T CONNECTIONS Ø8
- CD0-0392-A03 1X T CONNECTIONS Ø8
- CD0-0390-B01 2X T CONNECTIONS Ø8
- CD0-0399 1X REDUCTION Ø6-8
- CD0-0391-A02 2X 90° CONNECTIONS Ø8
- CD0-0391-A03 1X 90° CONNECTIONS Ø8
- XMC-855 2X STICKERS
- CD0-0394-A02 2X STRAIGHT ADAPTORS Ø8
- CD0-0323-A03 1X 4m AL PIPING Ø8
- CD0-0323-A01 2X 4m AL PIPING Ø8
- CD0-0324-A01 2X 5m SHEATH Ø10
- CD0-0324-A03 1X 5m SHEATH Ø8
- CD0-0336 1X PULL HANDLE 2 m
- CD0-0335 1X PULL HANDLE 3.2 m
- CD0-0393-A02 7X ATOMIZER NOZZLES
- CD0-0561 1X BRACKETS

















# CMSST6 2KG

CMO-SST6-A01 € 499,00 (C)

## SERIES 6

- Fire extinguishing system manually activated, engineered for saloon cars requiring a durable and high-performance fire suppression system
- Delivers fire suppression performance through a precision-engineered nozzle and tubing layout to maximize effectiveness
- Suitable for electric and hybrid cars

MADE IN ITALY

|   |  |
|---|--|
| <br>CDO-0394-A02 1X   | <br>CDO-0561 1X       |
| <br>CDO-0390-B01 1X   | <br>CDO-0399 1X       |
| <br>CDO-0392-A02 3X  | <br>CDO-0392-A03 1X  |
| <br>CDO-0391-A02 2X | <br>CDO-0391-A03 1X |
| <br>CDO-0336 1X     | <br>CDO-0335 1X     |
| <br>XMC-855 2X      | <br>CDO-0393-A01 7X |
| <br>CDO-0323-A03 1X | <br>CDO-0323-A01 2X |
| <br>CDO-0324-A01 2X | <br>CDO-0324-A03 1X |

## SALOON

Ø 130 MM  
STEEL BOTTLE  
FK-5-1-12 CLEAN AGENT

**NEW**



### SERIE 6 SALOON TECH. LIST 16 - CMSST6 2KG

| Ref.         | Extinguishant  | Total weight* |
|--------------|----------------|---------------|
| CMO-SST6-A01 | 2 kg FK-5-1-12 | 3.55 kg ±5%   |

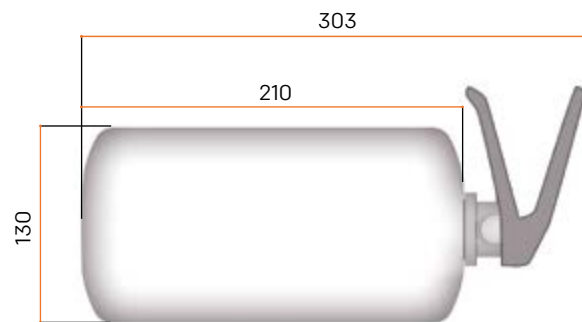

MEASUREMENTS IN MM

# CMSST6 3KG

CMO-SST6-B01 € 589,00 (C)

## SERIES 6

Same features as CMO-SAL6-C01 but with 160mm bottle and 3 kg extinguishant.

MADE IN ITALY



**NEW**

### SERIE 6 SALOON TECH. LIST 16 - CMSST6 3KG

| Ref.         | Extinguishant  | Total weight* |
|--------------|----------------|---------------|
| CMO-SST6-B01 | 3 kg FK-5-1-12 | 5.1 kg ±5%    |

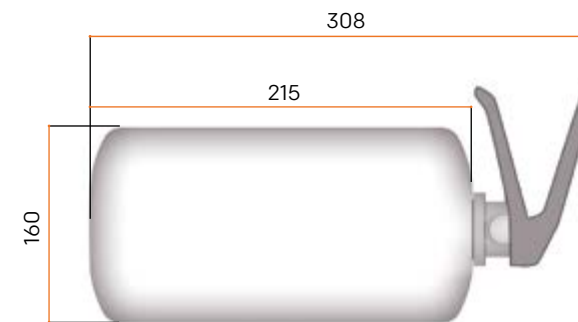

MEASUREMENTS IN MM

|  |  |
|--|--|
| <br>CDO-0394-A02 1X   | <br>CDO-0561 1X       |
| <br>CDO-0390-B01 1X   | <br>CDO-0399 1X       |
| <br>CDO-0392-A02 3X   | <br>CDO-0392-A03 1X   |
| <br>CDO-0391-A02 2X  | <br>CDO-0391-A03 1X  |
| <br>CDO-0336 1X     | <br>CDO-0335 1X     |
| <br>XMC-855 2X      | <br>CDO-0393-A01 7X |
| <br>CDO-0323-A03 1X | <br>CDO-0323-A01 2X |
| <br>CDO-0324-A01 2X | <br>CDO-0324-A03 1X |



# CESST7 3KG

CEO-SST7-A01 € 539,00 (C)

## SERIE 7

- Fire extinguishing system electrically activated, engineered for electrical saloon cars requiring a durable and high-performance fire suppression system
- Delivers fire suppression performance through a precision-engineered nozzle and tubing layout to maximize effectiveness

MADE IN ITALY



MANUFACTURER: OMP  
MODEL: SERIES 7 SALOON 3KG  
HOM. NO: EX.072.26  
FIA STANDARD: TECH. LIST 16

## SALOON/RALLY

Ø 160 MM  
STEEL BOTTLE  
ECOLIFE PLUS  
EXTINGUISHING AGENT

**NEW**



### SERIE 7 SALOON TECH. LIST16 - CESST7

| Ref.         | Extinguishant     | Total weight* |
|--------------|-------------------|---------------|
| CEO-SST7-A01 | 3 kg ecolife plus | 5.45 kg ±5%   |

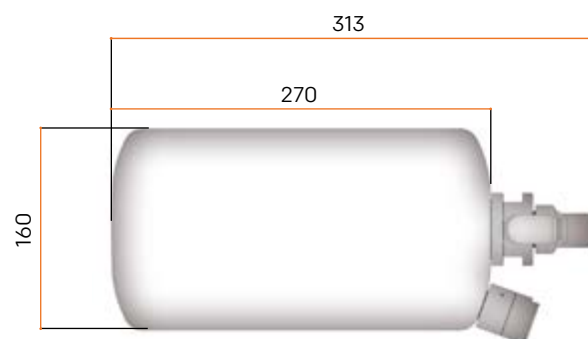

MEASUREMENTS IN MM

# CMSST7 3KG

CM0-SST7-A01 € 265,00 (C)

## SERIE 7

- Fire extinguishing system manually activated, engineered for saloon cars requiring a durable and high-performance fire suppression system.
- Delivers fire suppression performance through a precision-engineered nozzle and tubing layout to maximize effectiveness

MADE IN ITALY

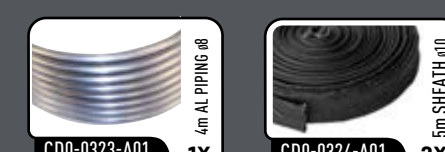
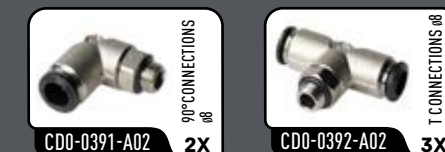
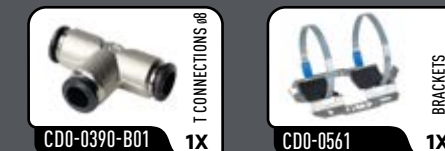

MANUFACTURER: OMP  
MODEL: SERIES 7 SALOON 3KG  
HOM. NO: EX.072.26  
FIA STANDARD: TECH. LIST 16

## SALOON

Ø 160 MM  
STEEL BOTTLE  
ECOLIFE PLUS  
EXTINGUISHING AGENT

**NEW**



### SERIE 7 SALOON TECH. LIST16 - CMSST7

| Ref.         | Extinguishant     | Total weight* |
|--------------|-------------------|---------------|
| CM0-SST7-A01 | 3 kg ecolife plus | 5.45 kg ±5%   |

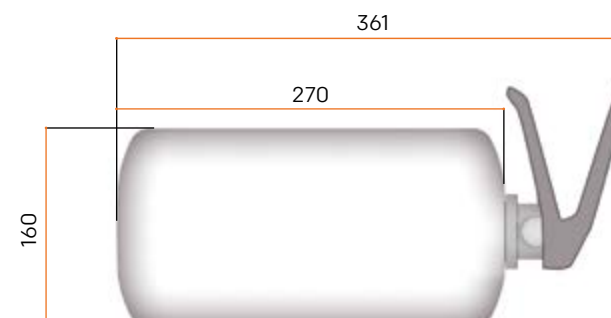

MEASUREMENTS IN MM

# HAND HELD EXTINGUISHER

**CBO-0323-A01** € 345,00 (C)

## STAINLESS STEEL EXTINGUISHER

- Hand held fire extinguisher complete with brackets and quick release clamps
- Extinguishing medium: 2 lt of FK-5-1-12
- FIA compliance: Appendix J, Article 253
- Compared to an AFFF fire extinguisher system, this FK-5-1-12 bottle is smaller and lighter

**SUITABLE FOR ELECTRIC AND HYBRID CARS**  
Ø 110MM

**HIGH VOLTAGE COMPATIBLE**  
(SEE ARTICLE 253-18.23)

MADE IN ITALY



## HAND HELD EXTIGUISHER

| Ref.         | Extinguishant  | Empty (kg) | Total weight* |
|--------------|----------------|------------|---------------|
| CBO-0323-A01 | 2 lt FK-5-1-12 | 1.15       | 3.15 kg       |

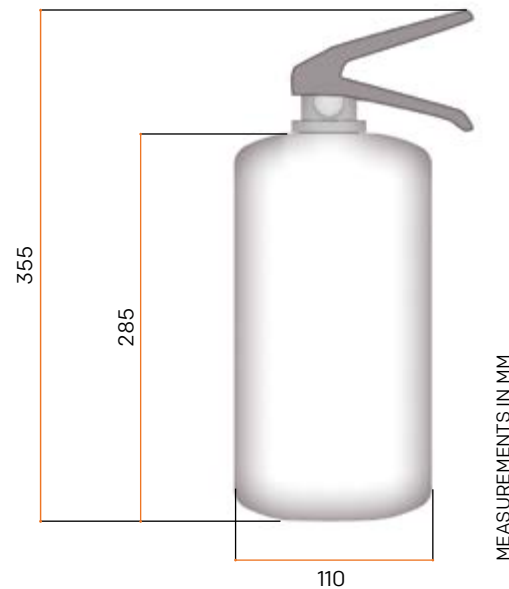

MEASUREMENTS IN MM



# HAND HELD EXTINGUISHER

**CBO-0325-A01** € 123,00 (C)

## STEEL EXTINGUISHER

- Aluminium hand held extinguishers
- Complete with aluminium brackets and stainless steel quick release clamps
- Extinguishing liquid: 2.4 lt EcoLifePlus

**HIGH VOLTAGE COMPATIBLE**  
(SEE ARTICLE 253-18.23)

Ø 130 MM



MADE IN ITALY



**NEW**

## HAND HELD EXTIGUISHER

| Ref.         | Extinguishant      | Total weight* |
|--------------|--------------------|---------------|
| CBO-0325-A01 | 2.4 lt EcoLifePlus | 5kg ±5%       |

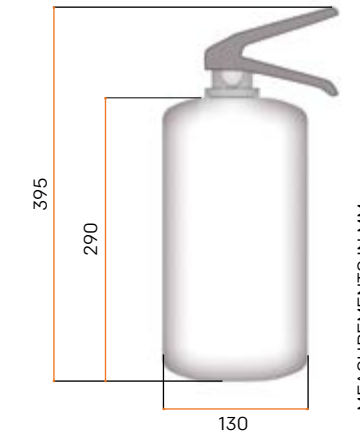

MEASUREMENTS IN MM

**NEW**

## HAND HELD EXTIGUISHER

| Ref.         | Extinguishant      | Total weight* |
|--------------|--------------------|---------------|
| CBO-0324-A01 | 2.4 lt EcoLifePlus | 4 kg ±5%      |

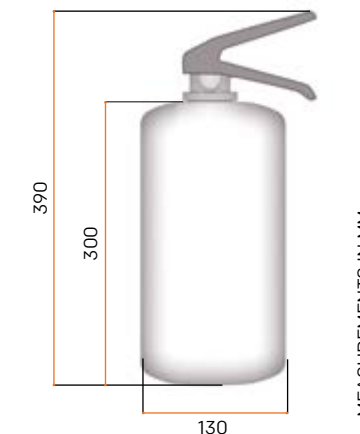

MEASUREMENTS IN MM

**CBO-0324-A01** € 219,00 (C)

## ALUMINIUM EXTINGUISHER

- Steel hand held extinguishers
- Complete with aluminium brackets and stainless steel quick release clamps
- Extinguishing liquid: 2.4 lt EcoLifePlus



MADE IN ITALY

# HAND HELD EXTINGUISHER

**CBO-0316-A01** € 82,00 (C)

MADE IN ITALY

## ALUMINIUM EXTINGUISHER

- Aluminium hand-held extinguisher
- 2 kg powder
- Complete with stainless steel brackets
- Quick-release clamps
- Fire class ABC
- Certification EN3

**HIGH VOLTAGE COMPATIBLE**  
(SEE ARTICLE 253-18.23)

Ø 108 MM



## HAND HELD EXTIGUISHER

| Ref.         | Extinguishant | Total weight* |
|--------------|---------------|---------------|
| CBO-0316-A01 | 2 kg powder   | 3.1 kg ±5%    |

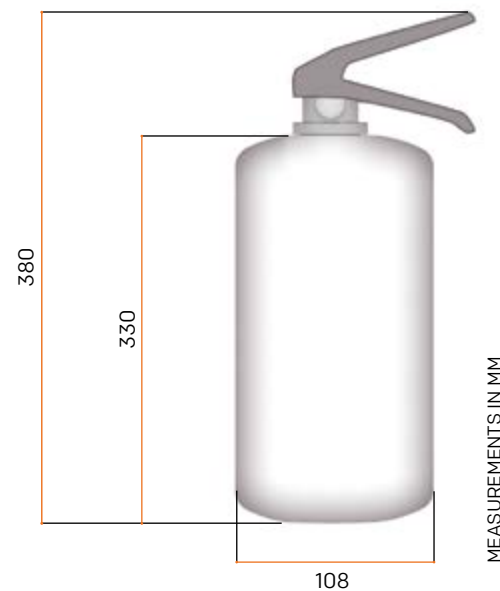

**NEW**

## HAND HELD EXTIGUISHER

| Ref.         | Extinguishant | Total weight* |
|--------------|---------------|---------------|
| CBO-0326-A01 | 3 kg powder   | 4.4 kg ±5%    |

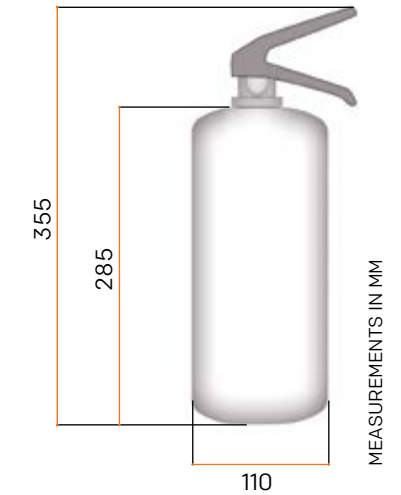

## HAND HELD EXTIGUISHER

| Ref.         | Extinguishant | Total weight* |
|--------------|---------------|---------------|
| CBO-0322-A01 | 4 Kkg power   | 5kg ±5%       |

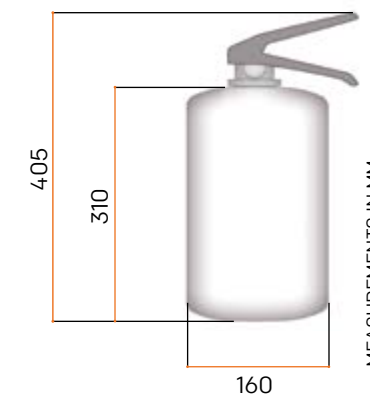

# HAND HELD EXTINGUISHER

**CBO-0326-A01** € 95,00 (C)

MADE IN ITALY

## ALUMINIUM EXTINGUISHER

- Aluminium hand held extinguisher, A/B/C classes
- Complete with aluminium brackets and stainless steel quick release clamps
- Extinguishing agent: 3 kg powder
- Fire class ABC
- Certification EN3\

**HIGH VOLTAGE COMPATIBLE**  
(SEE ARTICLE 253-18.23)

Ø 130 MM



# HAND HELD EXTINGUISHER

**CBO-0322-A01** € 104,00 (C)

MADE IN ITALY

## STEEL EXTINGUISHER

- Steel hand-held extinguisher
- 4 kg powder
- Suitable for A/B/C fire classes
- Complete with stainless steel brackets
- Quick release clamps
- Fire class ABC
- Certification EN3

**HIGH VOLTAGE COMPATIBLE**  
(SEE ARTICLE 253-18.23)

Ø 160 MM

# REPLACEMENT PARTS

## T CONNECTIONS

CD0-0412 € 10,50 (C)

"T" shaped 3-way connection, with quick attachments. Ø 8mm



## STRAIGHT ADAPTORS

CD0-0416 € 12,00 (C)

Straight connection, 1/8" with quick attachments. Ø 8mm



## 90° CONNECTIONS

CD0-0415 € 12,00 (C)

90° end connection, 1/8" with quick attachments. Ø 8mm



## Y CONNECTIONS

CD0-0414 € 17,00 (C)

"Y" shaped connection, with quick attachments. Ø 8mm



## ADAPTORS

CD0-0400-B01 € 37,50 (C)

8 mm straight connection



## ADAPTORS

CD0-0420 ON REQUEST

8mm bulkhead fitting



## CONNECTIONS

CD0-0394-A01 € 7,20 (C)

Straight connection Ø 8 mm (1/4" junction).



## CONNECTIONS

CD0-0395-A02 € 6,50 (C)

Straight connection Ø 8 mm (1/8" junction).



## T CONNECTIONS

CD0-0407 € 11,00 (C)

Y shaped connection with quick attachments Ø 8mm



## CONNECTIONS

CD0-0399 € 7,20 (C)

Reduction tube Ø 6-8 mm.



## T CONNECTIONS

CD0-0392-A02 € 11,00 (C)

1/8" connection, "T" shaped with quick couplings. Ø 8 mm



## T CONNECTIONS

CD0-0392-A03 € 8,00 (C)

1/8" connection, "T" shaped with quick couplings. Ø 6 mm



## T CONNECTIONS

CD0-0390-B01 € 11,00 (C)

3-way connection with quick attachments, Ø 8 mm.



## 90° CONNECTIONS

CD0-0391-A02 € 10,00 (C)

90° end connection, 1/8" shaped with quick attachments. Ø 8 mm



## 90° CONNECTIONS

CD0-0391-A03 € 6,80 (C)

90° end connection, 1/8" shaped with quick attachments. Ø 6 mm



## NOZZLES

CD0-0454 ON REQUEST

Nozzle specifically for CEFAL4/CESAL4E



## NOZZLES

CD0-0410 € 104,00 (C)

Nozzle (cockpit) specifically for CESAL4E



## NOZZLES

CD0-0411 € 104,00 (C)

Nozzle (cockpit) specifically for CESAL5E



# REPLACEMENT PARTS

## NOZZLES

CD0-0393-A01 € 10,00 (C)

Atomizer nozzle (engine bay)



## ENGINE BAY NOZZLES

CD0-0393-A02 € 9,80 (C)

Atomizer nozzle (engine bay)



## ALUMINIUM PIPING

CD0-0323-A01 € 10,50 (C)

Aluminium tubing. Ø 8 mm L 4 m.



## ALUMINIUM PIPING

CD0-0323-A03 € 10,50 (C)

Aluminium tubing. Ø 6 mm L 3 m.



## PIPING

CD0-0323-B01 € 61,00 (C)

Aluminium tubing Ø 6 mm - L. 3 m



## PIPING

CD0-0323-B02 € 65,00 (C)

Aluminium tubing Ø 8 mm - L. 5 m



## FIRE PROOF SLEEVE

CD0-0324-A01 € 16,00 (C)

Fire resistant sheath 5m roll, Ø 10 mm



## FIRE PROOF SLEEVE

CD0-0324-A02 € 16,00 (C)

Fire resistant sheath 5m roll Ø 6mm



## FIRE PROOF SLEEVE

CD0-0324-A03 € 16,00 (C)

Fire resistant sheath 5m roll Ø 8mm



## REMOTE CONTROLLER

CD0-0453 ON REQUEST

Remote controller for ECU CD0-0380-A02/A04/A06/A08



## WIRING

CD0-0433 ON REQUEST

Extension to connect the bottle with AMP connector.



## WIRING

CD0-0436 ON REQUEST

Wiring for Classic ECU CD0-0380-A01 A03 A05 A07



## WIRING

CD0-0430 ON REQUEST

Wiring for remote ECU CD0-0380-A02 A04 A06 A08 C.



## WIRING

CD0-0431 ON REQUEST

M5 extension (for activation button CD0-0432 and remote controller CD0-0453).



## WIRING

XMC-398-CAV € 18,00 (C)

Control box cable.



## WIRING

CD0-0410 € 104,00 (C)

Electric extinguisher valve cable w. jack.



## Y CONNECTIONS

CD0-0435 ON REQUEST

"Y" M5 connector to connect more activations buttons CD0-0432



## PUSH BUTTON COVER

CD0-0441 € 9,00 (C)

Protection for M12 activation button CD0-0432



# REPLACEMENT PARTS

## CONTROL BOX

CD0-0398 € 129,00 (C)

Control box for electrically activated units with wiring harness 1,5 m



## ACTIVATION BUTTON

CD0-0432-A02 € 25,00 (C)

Lenght 150 cm

CD0-0432-A01  
Lenght 50 cm

M12 Activation button with M5 connector



## PUSH BUTTON COVER

XMC-CD00094 € 9,00 (C)

Protection for M16 activation button EA0-0467



## BONNET PINS

CD0-0408 € 69,00 (C)

Fixing brackets with clamps for 130mmø. Anti-torpedo. (no picture)



## BRACKET

CD0-0418 € 52,00 (C)

Brackets: CB0-0323-A01 CE0-FAL4-A01



## BRACKET

CD0-0309 € 27,00 (C)

Brackets for STEEL HAND HELD extinguishers Ecolife: CB0-0319-A01, CB0-0325-A01, CB0-0324-A01 ø 132 mm CB0-0326-A01



## BRACKET

CD0-0356 € 27,50 (C)

Bracket for ALUMINIUM HAND HELD extinguisher: CB0-0351-A01, CB0-0325-A01, CB0-0324-A01 ø 130 mm



## COCKPIT NOZZLE BRACKETS

CD0-0409 € 28,00 (C)

Cockpit nozzle fixing bracket for: CD0-0410



## STICKER

XMC-855 € 1,00 (C)

Sticker.



## CABLE

CD0-0335 € 24,50 (C)

Pull cable for mechanically operated systems.



## BRACKET

CD0-0561 € 39,00 (C) **NEW**

Antitorpedo bracket and clamps for "serie 6"



## BRACKET

CD0-0600 € 49,00 (C) **NEW**

Antitorpedo bracket and clamps for "serie 7"



## NOZZLES

XMC-390 ON REQUEST **NEW**

Specific nozzle for Hand held extinguisher



## NOZZLES

XMC-CD00091 ON REQUEST **NEW**

Specific nozzle for Hand held extinguisher



## ACTIVATION BUTTON

XMC-CD00093 ON REQUEST **NEW**

Waterproof push button for external control



## STRAIGHT CONNECTIONS

CD0-0394 € 7,20 (C)

Straight connection (1/4" junction).



## STRAIGHT CONNECTIONS

CD0-0395-A01 € 7,20 (C)

Straight connection (1/8" junction).



## T CONNECTIONS

CD0-0392-A01 € 8,40 (C)

1/8" connection, "T" shaped with quick couplings.



## 90° CONNECTIONS

CD0-0391-A01 € 10,00 (C)

90° end connection, 1/8" shaped with quick attachments.



## T CONNECTIONS

CD0-0390-A01 € 11,00 (C)

T connection (1/8" junction).



## BRACKETS

CD0-0404 € 27,50 (C)

Bracket only for OMP Sport CB0-0372-A01



## BRACKETS

CD0-0405 € 32,50 (C)

Bracket for STEEL extinguisher CB0-0322-A01, ø 160 mm



## BRACKETS

CD0-0312 € 28,50 (C)

Brackets for STEEL HAND HELD extinguishers Ecolife: CAB-0316, ø 108 mm



## BRACKET

CD0-0400-B01 € 37,50 (C)

Antitorpedo bracket and clamps for CEFAL3.



## BRACKETS

CD0-0300-A01 € 17,00 (C)

Anti-torpedo tabs for mono brackets extinguishers (e.g. CEFAL3).



## BRACKETS

CD0-0311-A01 € 19,50 (C)

Anti-torpedo tabs for double brackets extinguishers.



## BRACKET

CD0-0401-B01 € 37,50 (C)

Antitorpedo bracket and clamps for CESAL3.



## WIRING

XMC-CAB-360E € 58,00 (C)

Control box cable.



## CONTROL BOX

CD0-0360 € 272,00 (C)

Control box for electrically activated extinguishing systems. With new advanced electronic unit FIA 8865-2015 homologated. IP55 waterproof standard certified.



## CONTROL BOX

CD0-0360-SP ON REQUEST

Control box for extinguishing system - no activation button

# OLD REPLACEMENT PARTS



# STEERING WHEELS

# 320 HYBRID S

ODO-2048 ON REQUEST

MADE IN ITALY

## SUPER PROFESSIONAL RALLY STEERING WHEEL

- Flat steering wheel made with a new exclusive composite technology combining carbon fiber and Dyneema®
- 300% more resistant and 20% lighter than standard carbon steering wheels
- Prepared for installation of 4 buttons (not included)
- Designed and developed in cooperation with 4-time WRC World Champion Volkswagen Motorsport
- CARBON
- FLAT
- SUPPLIED WITH HORN BUTTON

WITH Dyneema®  
**OVER 20% LIGHTER**  
**300% MORE RESISTANT**  
IN COMPARISON WITH CARBON VERSION

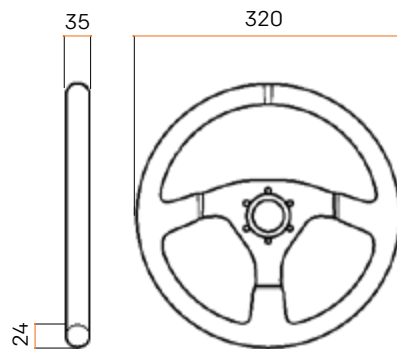

**FLAT**

**DIAMETER:** 320 mm  
**HANDGRIP:** oval 35x24 mm



SUEDE LEATHER



CARBON FIBER AND DYNEEMA®



# 310 ALU GT

ODO-2044 € 475,00 (C)

MADE IN ITALY

## SUPERLIGHT PROFESSIONAL GT STEERING WHEEL

- Completely made of aluminium and suede leather
- Designed and ready for installation of the most popular electronic displays, such as MoTeC C125 and AiM MX
- No stitching
- FLAT
- ALUMINIUM



Designed and ready for installation of the most popular electronic displays, such as MoTeC C125 and AiM MX.



ITALIAN FLAG COLORED STITCHING



BLACK ANODIZED SPOKES



SUEDE LEATHER

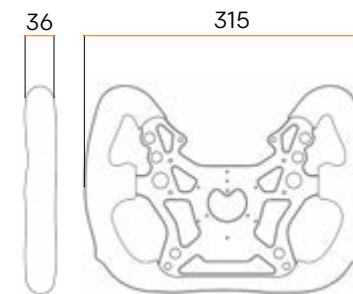

**FLAT**

**DIAMETER:** 315 mm  
**HANDGRIP:** 36x30 mm

# 320 CARBON S

ODO-2032 ON REQUEST

MADE IN ITALY

## SUPERLIGHT PROFESSIONAL STEERING WHEEL

- Carbon steering wheel manufactured as a single integral piece
- Black stitching
- **FLAT**
- SUPPLIED WITH HORN BUTTON

**50% LIGHTER  
15% MORE RESISTANT**  
IN COMPARISON WITH STANDARD VERSION



DESIGNED IN COOPERATION WITH  
P. SOLBERG



SUEDE LEATHER



CARBON MADE SPOKES

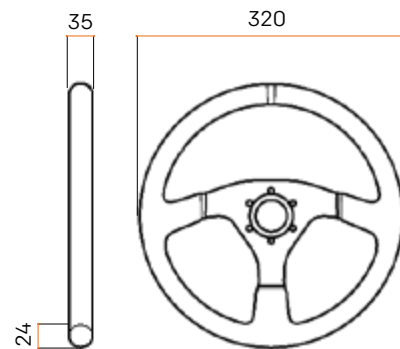

**FLAT**

**DIAMETER:** 320 mm  
**HANDGRIP:** oval 35x24 mm

# 350 CARBON D

ODO-2028 ON REQUEST

MADE IN ITALY

## SUPERLIGHT PROFESSIONAL DISHED STEERING WHEEL

- Carbon steering wheel manufactured as one integral piece
- **DISHED**
- SUPPLIED WITH HORN BUTTON

**50% LIGHTER  
15% MORE RESISTANT**  
IN COMPARISON WITH STANDARD VERSION

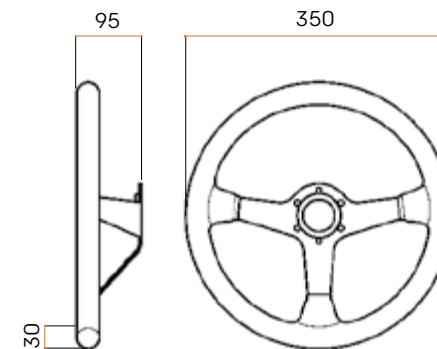

**DISHED**

**DIAMETER:** 350 mm  
**HANDGRIP:** round 30 mm



SUEDE LEATHER



CARBON MADE SPOKES

# 320 ALU SP

ODO-2042-A02 € 290,00 (C)

MADE IN ITALY

## LIGHT PROFESSIONAL STEERING WHEEL

- Made entirely of aluminium and suede leather
- Perforated version with central hole, supplied with horn button
- Derived from the 320 Carbon S model, designed in cooperation with P. Solberg (FIA World RX 2014/2015 Winner).
- No stitching
- **FLAT**
- **ALUMINIUM**
- **SUPPLIED WITH HORN BUTTON**

RED BUTTONS FOR CONTROLLING TWO SEPARATE ACCESSORY SWITCHES (e. g. one horn and the other for high beams)



BLACK ANODIZED SPOKES



SUEDE LEATHER

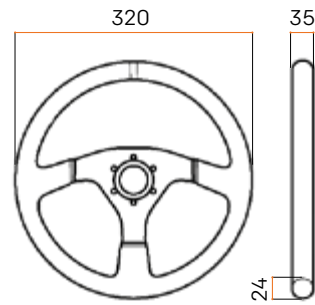

# 320 ALU S

ODO-2042-A01 € 290,00 (C)

Same characteristics as ODO-2042-A02.

Without central horn button.

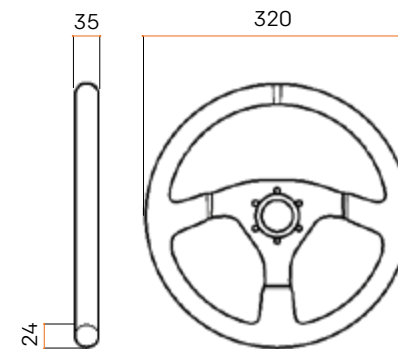

**FLAT**

**DIAMETER:** 318 mm  
**HANDGRIP:** oval 35x24 mm

# 320 ALU RALLY

ODO-2042-A03 € 290,00 (C)

MADE IN ITALY

## THREE SPOKES FLAT ALUMINIUM STEERING WHEEL IN SUEDE LEATHER.

- Shaped handgrip and spokes to enhance driving feel and comfort
- Lightweight materials for optimal performance
- No stitching
- **FLAT**
- **ALUMINIUM**
- **SUPPLIED WITH HORN BUTTON**



DESIGNED IN COOPERATION WITH ŠKODA MOTORSPORT, relying over the years on feedback from rally stars such as Kalle Rovanperä



BLACK ANODIZED SPOKES



SUEDE LEATHER

# 320 ALU

ODO-2042-A04 € 290,00 (C)

MADE IN ITALY

## SUPER PROFESSIONAL GT AND RALLY STEERING WHEEL

- Designed for precision and adaptability in GT and Rally applications
- Lightweight aluminium construction for strength without excess mass 320 mm diameter with oval grip for improved handling comfort
- Black suede leather covering for secure grip
- Revised spoke design to optimize central space
- Central perforation for horn button compatibility
- Simplified cockpit integration
- **FLAT**
- **ALUMINIUM**

XOD-2042-PUL € 8,00 (C)

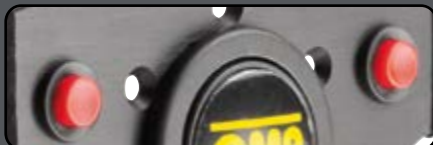

OPTIONAL RED BUTTONS

CD0-1960 € 15,50 (C)



OPTIONAL HORN BUTTONS



SUEDE LEATHER

**NEW**

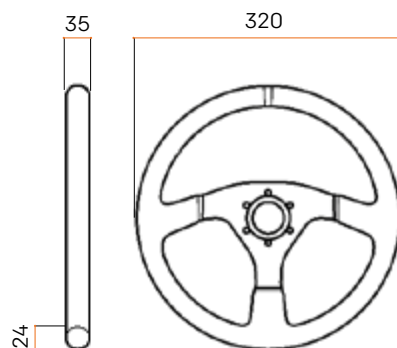

**FLAT**

**DIAMETER:** 320 mm  
**HANDGRIP:** oval 35x24 mm



# RECCE

ODO-2046 € 300,00 (C)

MADE IN ITALY

## SUPERLIGHT PROFESSIONAL RALLY STEERING WHEEL

- Flat steering wheel made of aluminium, 350 mm diameter
- Round 30 mm handgrip for secure and comfortable grip
- Colored marks on the crown indicating steering wheel angles (0° - 25° - 55° - 100° - 160°) for rally notes
- **FLAT**
- **ALUMINIUM**
- **SUPPLIED WITH HORN BUTTON**



COLORED MARKS

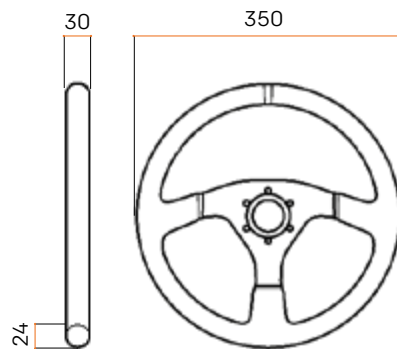

**FLAT**

**DIAMETER:** 350 mm  
**HANDGRIP:** round 30 mm

SUEDE LEATHER

# VELOCITÀ SUPERLEGGERO

ODO-2020 € 290,00 (C)

MADE IN ITALY

## SUPERLIGHT PROFESSIONAL GT STEERING WHEEL

- 40% lighter than equivalent model Velocità OD/1958.
- **FLAT**
- **ALUMINIUM**
- **SUPPLIED WITH HORN BUTTON**

**40% LIGHTER**  
IN COMPARISON WITH STANDARD VERSION



BLACK ANODIZED SPOKES



SUEDE LEATHER

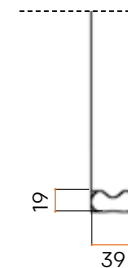
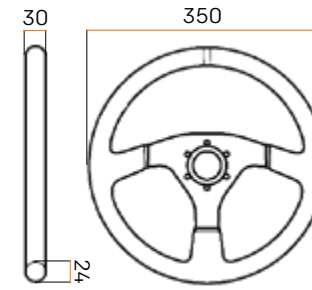

# VELOCITÀ OV SUPERLEGGERO

ODO-2035 € 340,00 (C)

Same characteristics as ODO-2020.  
Oval section version. Diameter: 320 mm



CURVED SECTION

# CORSICA SUPERLEGGERA

ODO-2021 € 290,00 (C)

## LIGHT PROFESSIONAL STEERING WHEEL

- 40% lighter than the equivalent Corsica ODO-1954 model
- **DISHED**
- ALUMINIUM
- SUPPLIED WITH HORN BUTTON

**40% LIGHTER**  
IN COMPARISON WITH STANDARD VERSION

MADE IN ITALY

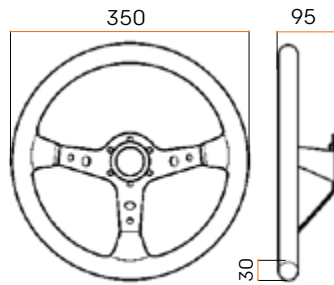

BLACK ANODIZED SPOKES



SUEDE LEATHER

# CORSICA OV SUPERLEGGERO

ODO-2034 € 340,00 (C)

Same features as ODO-2021

OVAL HANDGRIP SHAPED

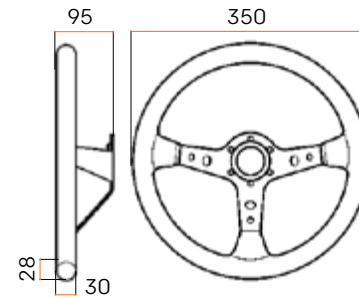
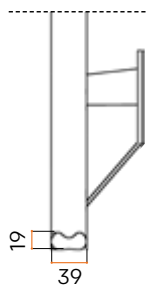

ODO-1954-073  
In suede leather.  
Black anodized spokes.  
Red stitching.

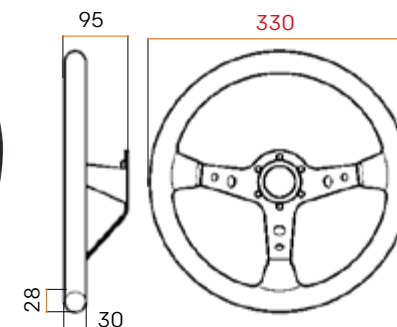

# CORSICA

ODO-1954 € 199,00 (C)  
ODO-1956 € 189,00 (C)

## PROFESSIONAL STEERING WHEEL

- Made in aluminium and steel
- **DISHED**
- ALUMINIUM
- SUPPLIED WITH HORN BUTTON

### SUEDE LEATHER



ODO-1954-371  
In suede leather.  
Titanium colour anodized spokes.  
Yellow stitching.



ODO-1954-071  
In suede leather.  
Black anodized spokes.  
Yellow stitching.



ODO-1954-075  
In suede leather.  
Blue anodized spokes.  
Yellow stitching.

### SMOOTH LEATHER



ODO-1956-073  
In smooth leather.  
Black anodized spokes.  
Red stitching.



ODO-1956-071  
In smooth leather.  
Black anodized spokes.  
Yellow stitching.

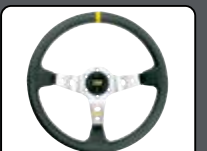

ODO-1956-371  
In smooth leather.  
Gray anodized spokes.  
Yellow stitching.

MADE IN ITALY

# CORSICA 330

ODO-2012 € 225,00 (C)

In suede leather. Black anodized spokes. Yellow stitching.

Diameter: 330 mm

MADE IN ITALY

ODO-1951 / 1950 € 185,00 (C)

MADE IN ITALY

### PROFESSIONAL STEERING WHEEL

- Made of aluminium and steel
- No stitching
- **DISHED**
- ALUMINIUM
- SUPPLIED WITH HORN BUTTON

#### SUEDE LEATHER



**ODO-1951-240**  
In suede leather.  
Blue anodized spokes. No stitching.

#### SMOOTH LEATHER



**ODO-1950-071**  
In smooth leather.  
Black anodized spokes. yellow stitching.



**ODO-1951-071**  
In suede leather.  
Black anodized spokes. Yellow stitching.



BLUE ANODIZED SPOKES



BLACK ANODIZED SPOKES



SUEDE LEATHER

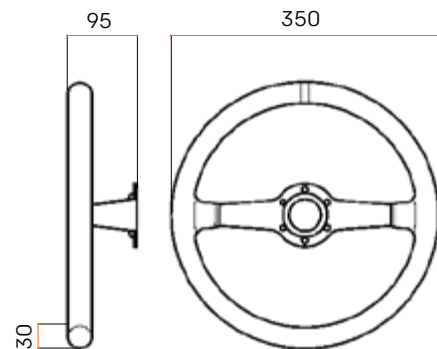

**DISHED**

**DIAMETER:** 350 mm  
**HANDGRIP:** round 30 mm  
**DEPTH:** 95 mm

ODO-1979 € 201,00 (C)  
ODO-1980 € 212,00 (C)

MADE IN ITALY

### PROFESSIONAL STEERING WHEEL

- Made of aluminium and steel
- **MID-DEPTH DISHED**
- ALUMINIUM
- SUPPLIED WITH HORN BUTTON

#### SUEDE LEATHER



**ODO-1979-071**  
In suede leather.  
Black anodized spokes. Black stitching.

#### SMOOTH LEATHER



**ODO-1980-073**  
In smooth leather.  
Black anodized spokes. Red stitching.



**ODO-1980-071**  
In smooth leather.  
Black anodized spokes. Yellow stitching.



BLACK ANODIZED SPOKES



SUEDE LEATHER

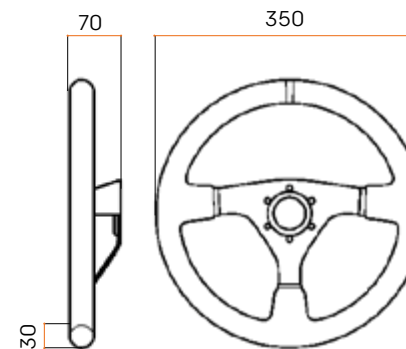

**DISHED**

**DIAMETER:** 350 mm  
**HANDGRIP:** round 30 mm  
**DEPTH:** 70 mm

# VELOCITÀ

**ODO-1957** € 225,00 (C)  
**ODO-1958** € 212,00 (C)

## PROFESSIONAL STEERING WHEEL

- Made of aluminium and steel
- **FLAT**
- ALUMINIUM
- SUPPLIED WITH HORN BUTTON

### SUEDE LEATHER



**ODO-1957**  
 In smooth leather.  
 Black anodized spokes.  
 Yellow stitching.

### SMOOTH LEATHER



**ODO-1958**  
 In suede leather.  
 Black anodized spokes.  
 Black stitching.



SMOOTH LEATHER



SUEDE LEATHER

# VELOCITÀ 380

**ODO-2030 / 1987** € 225,00 (C)



**ODO-2030-071**  
 In smooth leather.  
 Black anodized spokes.  
 black stitching.



**ODO-1987-071**  
 In suede leather.  
 Black anodized spokes.  
 Black stitching.

MADE IN ITALY

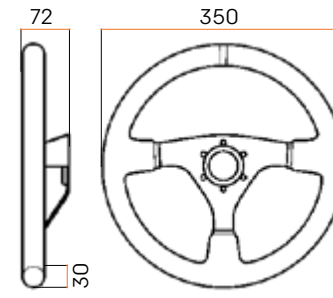
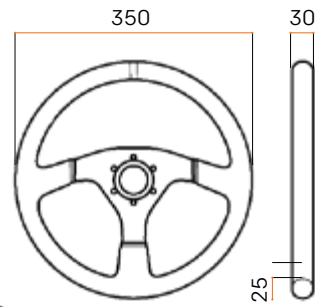

# RS

**ODO-2055** € 170,00 (C)

## ENTRY LEVEL STEERING WHEEL

- Three aluminum spokes
- Round grip in suede leather
- **MID-DEPTH DISHED**
- SUPPLIED WITH HORN BUTTON



SUEDE LEATHER

# SUPERQUADRO

**ODO-1990** € 210,00 (C)

- **FLAT**
- SUPPLIED WITH HORN BUTTON



BLACK ANODIZED SPOKES



SUEDE LEATHER

MADE IN ITALY



**DIAMETER:** 350 mm  
**HANDGRIP:** oval 35x30 mm

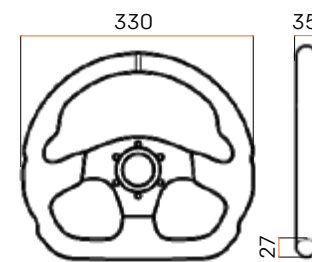
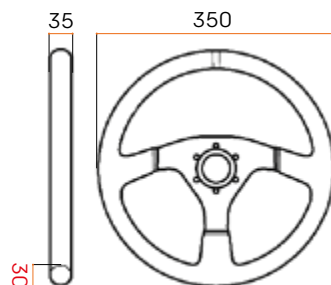

# TARGA

ODO-2005 € 199,00 (C)

FLAT

DIAMETER: 330 mm  
HANDGRIP: oval 37x24 mm

SUPPLIED WITH HORN BUTTON

MADE IN ITALY

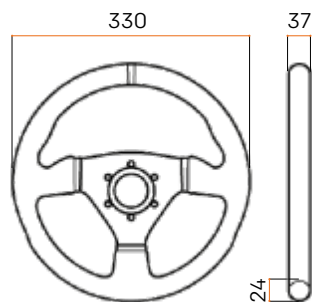

SUEDE LEATHER

# TRECENTO

ODO-1975 € 185,00 (C)

ODO-1976 € 199,00 (C)

FLAT

DIAMETER: 300x290 mm  
HANDGRIP: oval 37x27 mm

SUPPLIED WITH HORN BUTTON

SUEDE LEATHER

SMOOTH LEATHER



ODO-1976-071  
In smooth leather.  
Black anodized spokes,  
black stitching.



ODO-1957-071  
In suede leather.  
Black anodized spokes,  
yellow stitching.

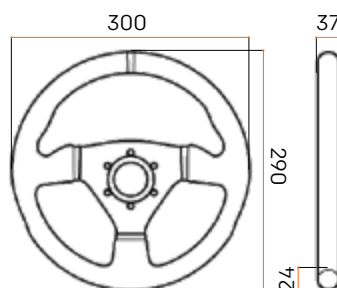

# KUBIC

ODO-1985 € 245,00 (C)

FLAT

DIAMETER: 310x265 mm  
HANDGRIP: oval 35x28 mm

SUPPLIED WITH HORN BUTTON

MADE IN ITALY

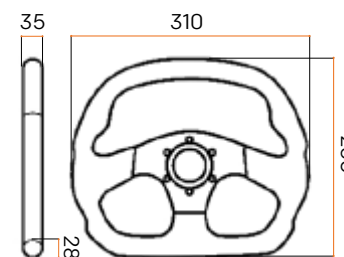

SUEDE LEATHER

# FORMULA QUADRO

ODO-1972 € 185,00 (C)

FLAT

DIAMETER: 250x230 mm  
HANDGRIP: oval 35x25 mm

SINGLE SEATER

MADE IN ITALY

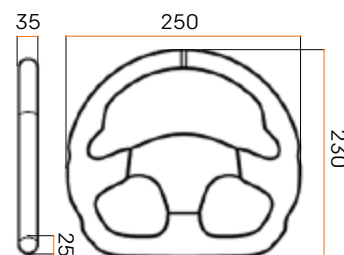

SUEDE LEATHER

# FOCUS ON

## COUNTERFEIT STEERING WHEELS ARE A REAL THREAT TO YOUR SAFETY

But how can we sort out a genuine OMP steering wheel from a fake?

### BEWARE OF

Too low prices / Altered OMP logo / Unofficial dealers  
Models or colors that you can't find on OMP catalog or website

Every OMP steering wheel is marked with an anti-counterfeiting hologram that certifies the authenticity and the quality of OMP products



**OMP HOLOGRAM**  
Example of an anti-counterfeiting hologram applied on rear spokes

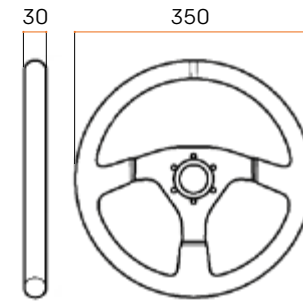

# MUGELLO

ODO-2023 € 115,00 (C)

FLAT

DIAMETER: 350 mm  
HANDGRIP: 30 mm

SUPPLIED WITH HORN BUTTON

# INDY OPEN

ODO-2017 € 245,00 (C)

FLAT

DIAMETER: 350X170 mm  
HANDGRIP: oval 35x25 mm

SINGLE SEATER

MADE IN ITALY

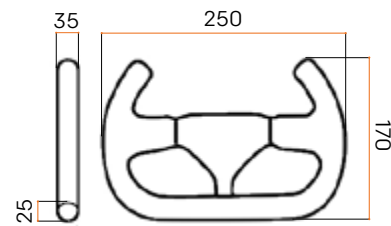

SUEDE LEATHER

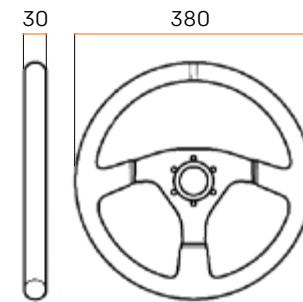

# SAND

ODO-2031 € 159,00 (C)

FLAT

DIAMETER: 380 mm  
HANDGRIP: 30 mm

SUPPLIED WITH HORN BUTTON

MADE IN ITALY

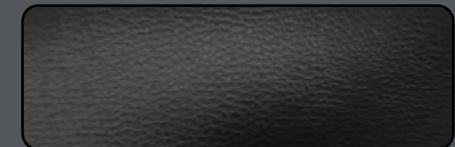

SIMULATING SMOOTH LEATHER

# CROMO

ODO-2018 € 145,00 (A)

FLAT

DIAMETER: 350x330 mm  
HANDGRIP: oval 32x27 mm

SUPPLIED WITH HORN BUTTON



PERFORATED SYNTHETIC LEATHER INSERTS

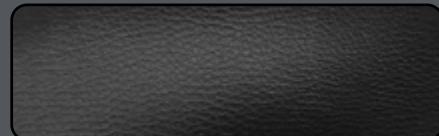

SYNTHETIC SMOOTH LEATHER

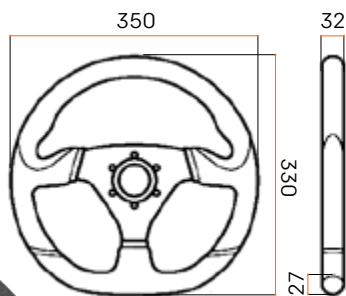

# ASSO

ODO-2019 € 145,00 (A)

FLAT

DIAMETER: 350 mm  
HANDGRIP: oval 35.5x27 mm

SUPPLIED WITH HORN BUTTON

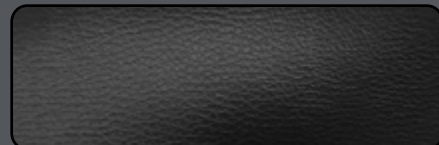

SMOOTH SYNTHETIC LEATHER

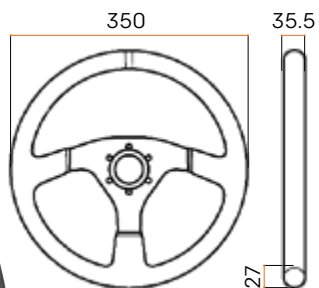

# RACING GP

ODO-1981 € 140,00 (A)

FLAT

DIAMETER: 330 mm  
HANDGRIP: oval 32x27 mm

SUPPLIED WITH HORN BUTTON



BLACK ANODIZED SPOKES

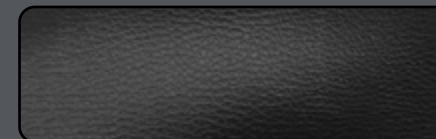

SYNTHETIC SMOOTH LEATHER

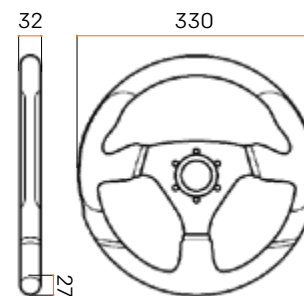

# TRECENTO UNO

ODO-1989 € 140,00 (A)

FLAT

SUPPLIED WITH HORN BUTTON



BLACK ANODIZED SPOKES



PERFORATED SYNTHETIC LEATHER INSERTS

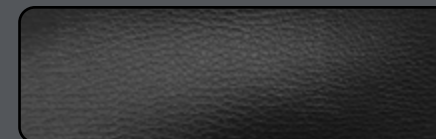

SYNTHETIC SMOOTH LEATHER

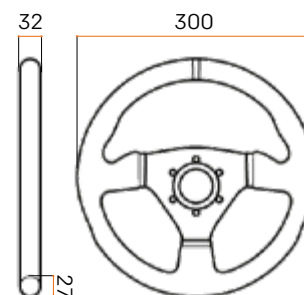

# STEERING WHEELS ACCESSORIES

## QUICK RELEASE HUB TO BE WELDED

- OS0-0024-A03** € 280,00 (C) **TO BE BOLTED**  
**OS0-0024-A04** € 450,00 (C) **TO BE BOLTED WITH CONNECTOR INCLUDED**

Quick release hub in aluminium with 6 holes. Compatible with 3 or 6 holes steering wheel. Recommended use of PTFE dry lube to get the best performance and preserve all components. Also available with 11 pin professional electrical connectors included (this part is an high performance interconnection engineered with arc-shape metal guides, which ensure a rapid and precise alignment of the 11 contacts. Aluminium body, IP68 sealing, 10000 cycles guarantee, high temperature and chemical resistance).

Connector model:  
 FISCHER SFE 104 A056-130 (male)  
 FISCHER DEE 104 A056-130 (female)

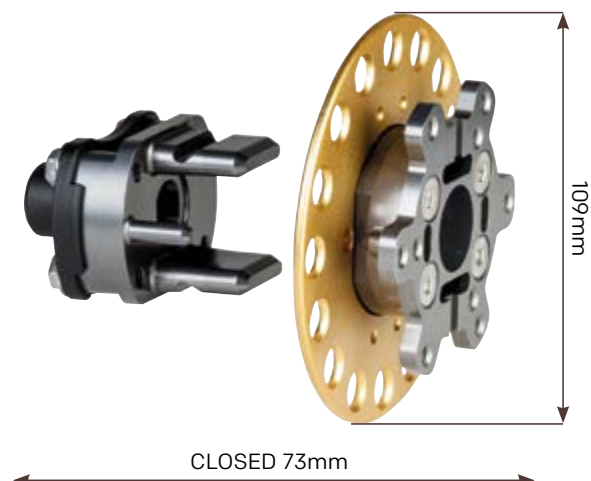

## QUICK RELEASE HUB TO BE BOLTED

- OS0-0024-A01** € 256,00 (C) **TO BE BOLTED**  
**OS0-0024-A02** € 440,00 (C) **TO BE BOLTED WITH CONNECTOR INCLUDED**

Quick release hub in aluminium with 6 holes. Compatible with 3 or 6 holes steering wheel. Recommended use of PTFE dry lube to get the best performance and preserve all components. Also available with 11 pin professional electrical connectors included (this part is an high performance interconnection engineered with arc-shape metal guides, which ensure a rapid and precise alignment of the 11 contacts. Aluminium body, IP68 sealing, 10000 cycles guarantee, high temperature and chemical resistance).

Connector model:  
 FISCHER SFE-104-A056-130 (male)  
 FISCHER DEE-104-A056-130 (female)

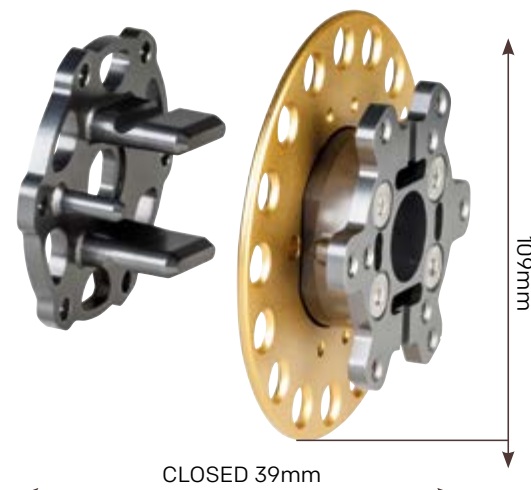

## QUICK RELEASE HUB

- OS0-0025-A01** € 269,00 (C) **TO BE WELDED**  
**OS0-0025-A02** € 288,00 (C) **TO BE WELDED**  
**OS0-0025-A03** € 246,00 (C) **TO BE BOLTED**  
**OS0-0025-A04** € 430,00 (C) **TO BE WELDED**

6 holes quick release hub in aluminium. With 'butterfly' shape to avoid interaction with shift paddle. Compatible with 3 or 6 holes steering wheels.

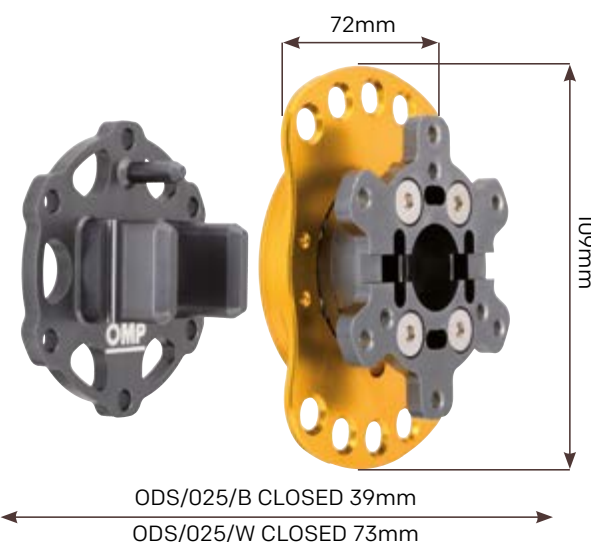

AVAILABLE ON REQUEST WITH PROFESSIONAL ELECTRICAL CONNECTOR

# STEERING WHEELS ACCESSORIES

## STEERING WHEEL SPACERS

Steering wheel spacer in anodized Ergal EN AW 7075 machined from solid. Specific grooves for wires and cables. Compatible with all 6x70mm steering wheels. Available in several heights:

Color: dark grey



## FIXED STEERING WHEEL SPACERS

- OS0-0023** € 119,00 (A)

Depth: 60 mm

- Anodized silver  
**OS0-0023-081**  
 Anodized black  
**OS0-0023-071**



## WHEEL PLATE

- ODO-2029** € 95,00 (C)

For use of up to 2 buttons (included). 2 drill points for attachment between steering wheel and hub. Fixing screws included.

Carbon fiber.  
**Thickness: 2.5 mm**



## WHEEL PLATE

- ODO-2026** € 124,00 (C)

Carbon fiber.  
**Thickness: 2.5 mm**

For use of up to 4 buttons (not included).

6 drill points for attachment.

Fixing screws included.



Example of mounted plate

## SPECIFIC WHEEL HUBS

- ODO-1960-...**

These steering wheel hubs have been designed so as to maintain the original steering wheel (flat model) position.

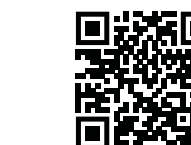

see the application list on [www.ompracing.com](http://www.ompracing.com) and on QR code



**ZN**  
ZERONOISE

**COMMUNICATION SYSTEMS**



# INDEX

## RALLY



**FEARLESS WW AMPLIFIER**  
Page 182



**HEADSET WW**  
Page 183



**FEARLESS AMPLIFIER**  
Page 186



**FEARLESS WRC  
CANBUS AMPLIFIER**  
Page 187



**FURY AMPLIFIER**  
Page 190



**BRAVE AMPLIFIER**  
Page 191

## OFFROAD



**FEARLESS OFFROAD**  
Page 188



**FURY OFFROAD**  
Page 189



**VALIANT HEADSET**  
Page 193



**VALIANT AMPLIFIER**  
Page 193



**HEADSET**  
Page 192

## CIRCUIT



**PIT-LINK AMPLIFIER**  
Page 196



**PIT HEADSET**  
Page 197



**EARPLUGS KIT**  
Page 198



**RADIO HEADSET**  
Page 199

## KARTING



**PIT-LINK TRAINER**  
Page 200



**PIT-LINK  
TRAINER HEADSET**  
Page 201

## RADIO HELMET KITS



**RADIO HELMET KIT O.F.**  
Page 202-203



**RADIO HELMET KIT F.F.**  
Page 202-203

## ACCESSORIES



**ADAPTORS**  
Page 204-205



**INTERCOM CABLES**  
Page 206



**SPARE PARTS**  
Page 207



**MAPLIGHTS**  
Page 209

## ZN LINK

- Replaceable cables – high modularity
- Mechanical issues easily fixable
- IP67 connectors
- Service cables included with the control unit
- Driver/co-driver cables available as options

## CLEARVOICE DIGITAL AUDIO

- Enhanced digital audio
- Signal stability
- Low latency
- Dynamic algorithm for voice isolation

## IP CERTIFICATION

- IP67 connectors
- IP-rated control units
- Robust design
- Product range specifically designed for off-road use

## ZN APP

- Full Control from mobile or tablet device.
- Wireless Connection
- Robust communication protocol
- User-Friendly Interface

## INTERCOM UPDATE

- OTA (Over-The-Air Update)
- Wi-Fi connectivity
- Reduced Maintenance Time
- ZN App Compatibility

## CAN-BUS INTERFACE

- Centralized Control
- Guaranteed Compatibility
- Advanced Customization
- Easy Integration

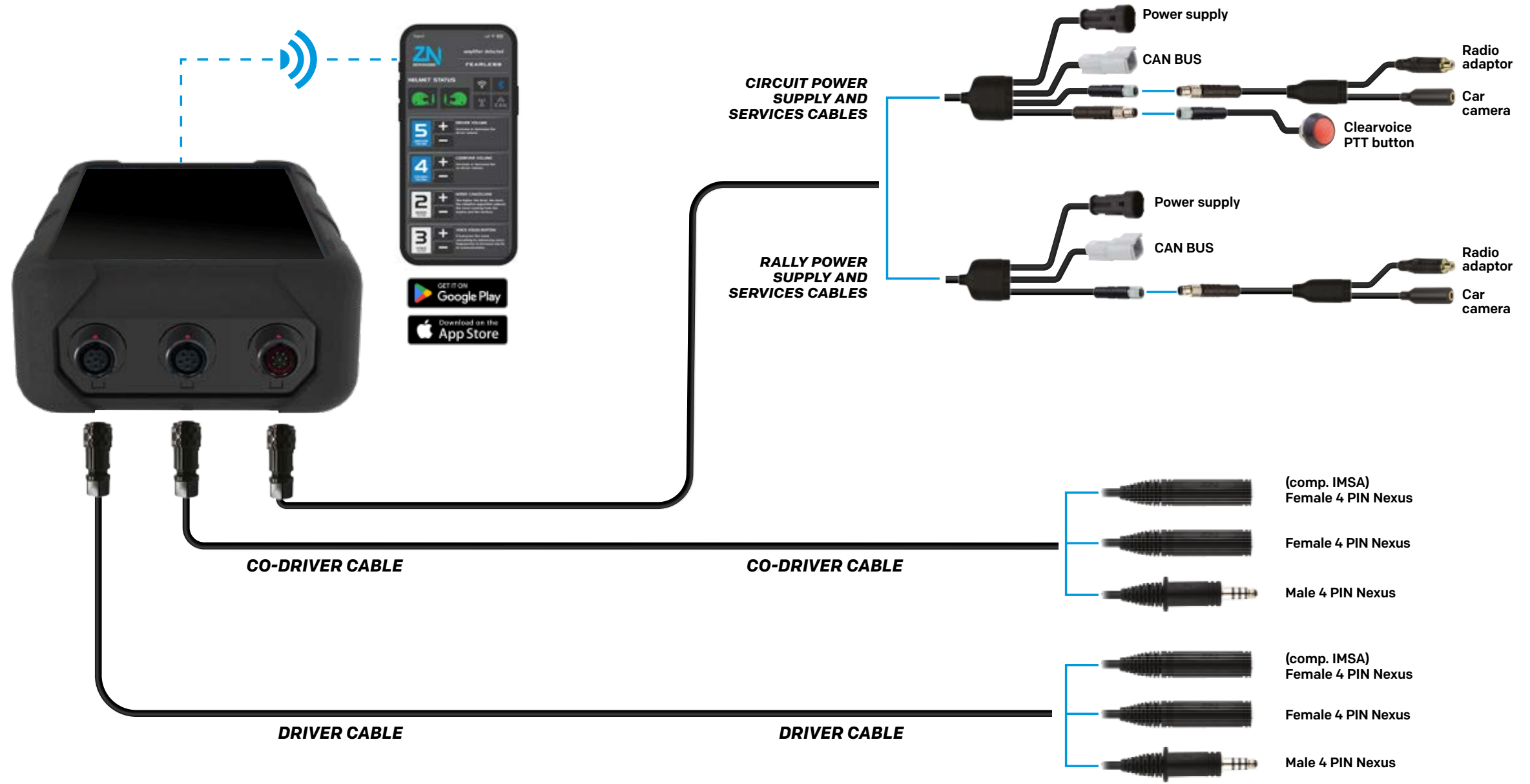

|                           | FEARLESS WIRELESS | FEARLESS | FEARLESS OFFROAD | FURY OFFROAD | PIT-LINK | FURY | BRAVE | VALIANT |
|---------------------------|-------------------|----------|------------------|--------------|----------|------|-------|---------|
| <b>FEATURE</b>            |                   |          |                  |              |          |      |       |         |
| DIGITAL AUDIO             | ✓                 | ✓        | ✓                | ✓            | ✓        | ✓    |       |         |
| ZN CLEARVOICE             | ✓                 | ✓        | ✓                | ✓            | ✓        |      |       |         |
| BLUETOOTH                 | ✓                 | ✓        |                  |              | ✓        |      |       |         |
| OTA UPDATE (OVER THE AIR) | ✓                 | ✓        | ✓                |              | ✓        |      |       |         |
| IP65                      | ✓                 | ✓        | ✓                | ✓            | ✓        |      |       |         |
| ZN LINK                   | ✓                 | ✓        | ✓                | ✓            | ✓        |      |       |         |
| CAN-BUS ready             | ✓                 | ✓        | ✓                |              | ✓        |      |       |         |
| PTT (PUSH TO TALK)        |                   |          |                  |              | ✓        |      |       |         |
| ZN APP                    | ✓                 | ✓        | ✓                |              | ✓        |      |       |         |

The Wired-Wireless (WW) System enables communication between driver and co-driver both in Wired and Wireless mode. When the helmet IS connected to the amplifier via cable, the communication works traditionally, also keeping compatibility with any Nexus communication system. When the helmet IS NOT connected to the amplifier via cable, the system switches automatically to the wireless mode with no interruption whatsoever.

### COMPONENTS

- WW Zeronoise Fearless Amplifier
- WW Bell Helmet radio kits / Helmet radio kits produced by other manufacturers
- WW Zeronoise Headsets / Headsets produced by other manufacturers
- Extensions and adaptors (if needed for different connector systems, e.g. components produced by other manufacturers)

SYSTEM DIAGRAM OF THE TYPICAL ZN WIRED/WIRELESS ARCHITECTURE FOR ILLUSTRATIVE PURPOSES ONLY

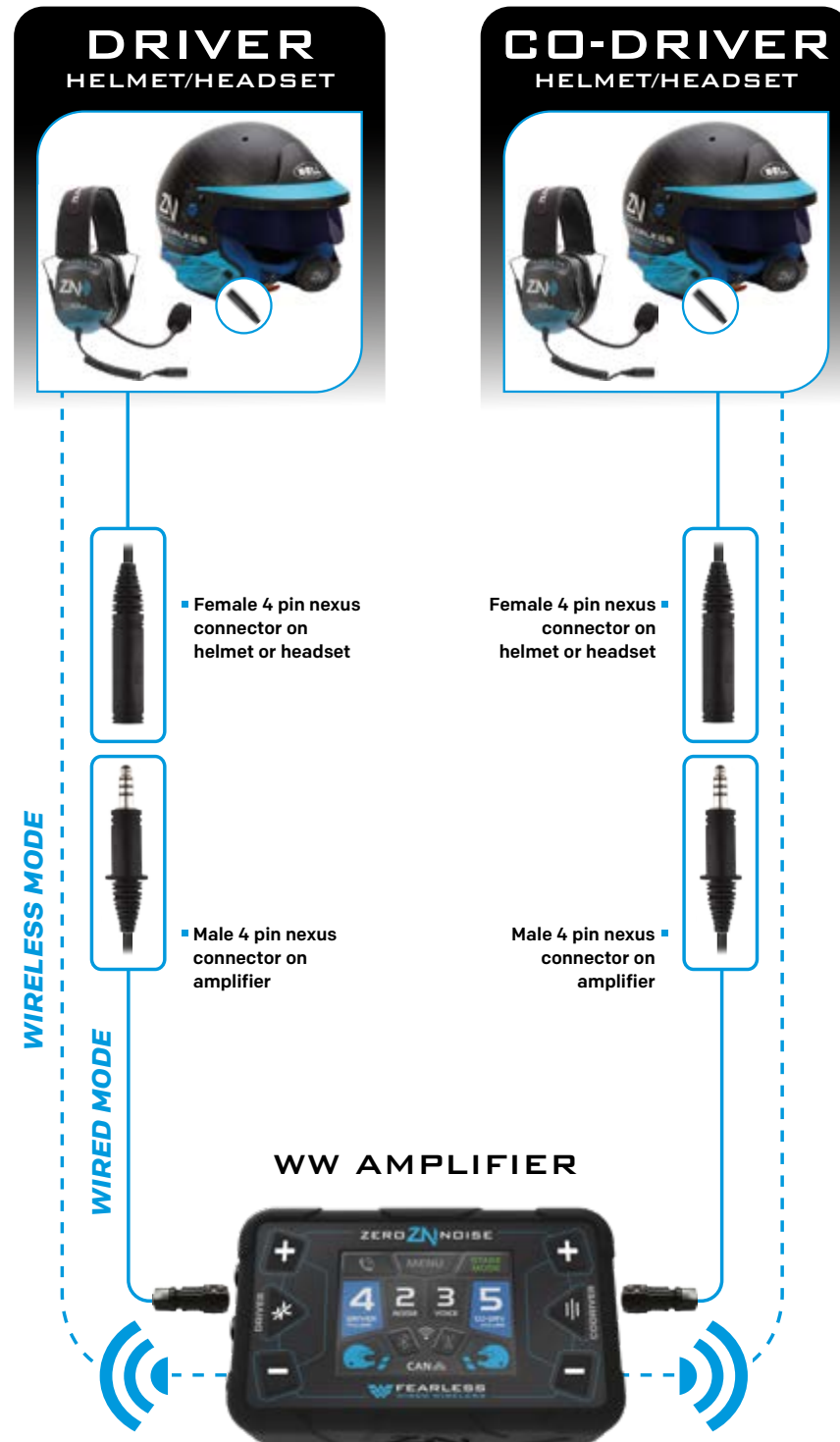

- PLEASE READ THE INSTRUCTIONS CAREFULLY BEFORE USING -



# FEARLESS WIRED WIRELESS

DIGITAL AMPLIFIER FOR RALLY USE

125 x 70 x 35 mm

6100049

€ 885,00 (Z)

The Fearless Wired Wireless Amplifier is a fully re-engineered communication system built for durability and performance in rally and off-road conditions. It allows to switch seamlessly from Wired to a super low latency Wireless communication inside and outside the car. Rated IP65 for dust and moisture protection, it features a silicone keyboard, IP67 panel-mounted connectors, and a 36% larger display for improved usability. The ClearVoice™ technology ensures clear communication in harsh environments through voice isolation algorithms. Combining wired and wireless military-grade encrypted connectivity, it works seamlessly with Bell Mag-10 Rally Carbon WW and HP10 Rally helmets.

## FEATURES

- WIRED and WIRELESS communication
- Clearvoice(TM) technology with adaptive noise cancelling and voice isolation
- Multifunction touch display
- Bluetooth
- Anti shock, anti vibration silicon cover
- Dual volume adjustment
- Easy fix system on roll bar or dashboard
- IP67 connectors for protection and easy replacement
- CAN-Bus integration with the car's control system
- Full Wi-Fi control from smartphone or tablet

## INCLUDED IN THE BOX

- Audio Out for car camera
- Audio IN/OUT radio connection
- 12V Filtered power cable
- CAN-BUS

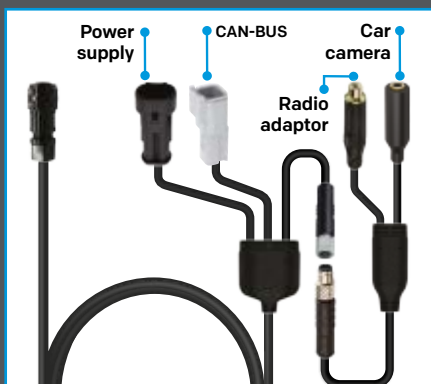

## WIRELESS / NEXUS CONNECTOR



## CLEARVOICE™



Cable to driver (2m)

Cable to co-driver (2m)

12V cable to car battery +  
Audio out for car camera +  
Audio in/out for radio

## DRIVER/CO-DRIVER CABLE NOT INCLUDED WITH AMPLIFIER

6100050 € 60,00 (Z)

You need to buy 2 cables (Driver and CO-driver)

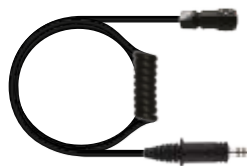

Connector: Male 4 PIN Nexus

6100051 € 60,00 (Z)

You need to buy 2 cables (Driver and CO-driver)



Connector: Female 4 PIN Nexus

6100052 € 60,00 (Z)

You need to buy 2 cables (Driver and CO-driver)



Connector: (comp. IMSA) Female 4 PIN Nexus

CABLE DETAILS PAGE 206

# HEADSET WIRED WIRELESS

HEADSET FOR RALLY USE

6100009

€ 440,00 (Z)

ZERONOISE WW HEADSET provides high hearing protection while being comfortable and lightweight. It integrates the WW technology, therefore it works both in Wired and Wireless mode. The high efficiency speakers are suitable for a conversation or listening to music. It also features a dynamic noise cancelling microphone and an adjustable flex boom.

It is fully compatible with all ZERONOISE AMPLIFIERS.

## FEATURES

- Integrated WW technology
- High efficiency speakers for music or voice
- Dynamic noise cancelling microphone Flex boom to adjust microphone
- High hearing protection
- Soft adjustable headband
- Optional cable available only Female 4 PIN Nexus version

## WIRELESS / NEXUS CONNECTOR



## ZN HEADSET WW MAINTAINS COMPATIBILITY WITH ANY NEXUS AMPLIFIER



6200010 € 80,00 (Z)

Wiring for headset WW female nexus 4 pin connector

## WIRED/WIRELESS RADIO KIT 10 SERIES

6300036 € 205,00 (Z)

Spare radio helmet kit with earcups and microphone suitable for HP10 WW and MAG-10 RALLY CARBON WW



A Rally communication system is a high-performance intercom designed for extreme motorsport conditions, enabling crystal-clear interaction between driver and co-driver. Built with advanced noise-cancellation algorithms, it isolates and enhances the voice and it eliminates engine roar and road vibrations. Zeronoise systems integrate digital processors, adaptive noise cancelling and voice isolation, and the possibility to set easily audio parameters. IP-rated housings ensure durability against dust, water, and shocks, while wireless and wired options deliver seamless, encrypted connectivity.

The intercoms also allow multiple connectivity options such as Bluetooth, Radio, Can-bus, and wi-fi to enable a full integration in every autoracing environment.

Zeronoise systems transform chaotic rally environments into zones of flawless communication—boosting speed, safety, and competitive edge.

### COMPONENTS

- Amplifiers
- Extensions and adaptors (if needed for different connector systems, e.g. components produced by other manufacturers)
- Helmet radio kits
- Headsets

SYSTEM DIAGRAM OF THE TYPICAL ZN WIRED/WIRELESS ARCHITECTURE FOR ILLUSTRATIVE PURPOSES ONLY

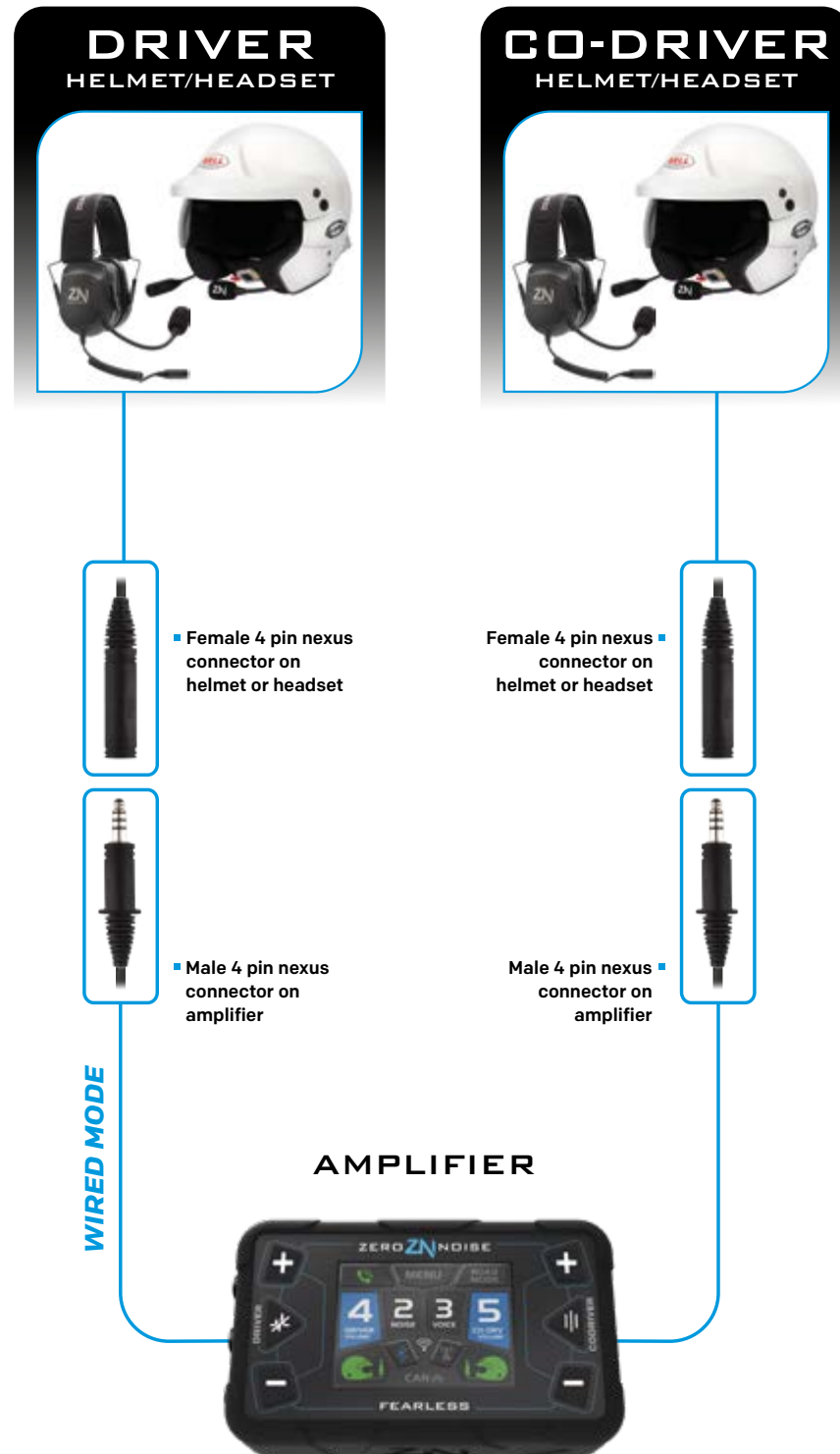

- PLEASE READ THE INSTRUCTIONS CAREFULLY BEFORE USING -

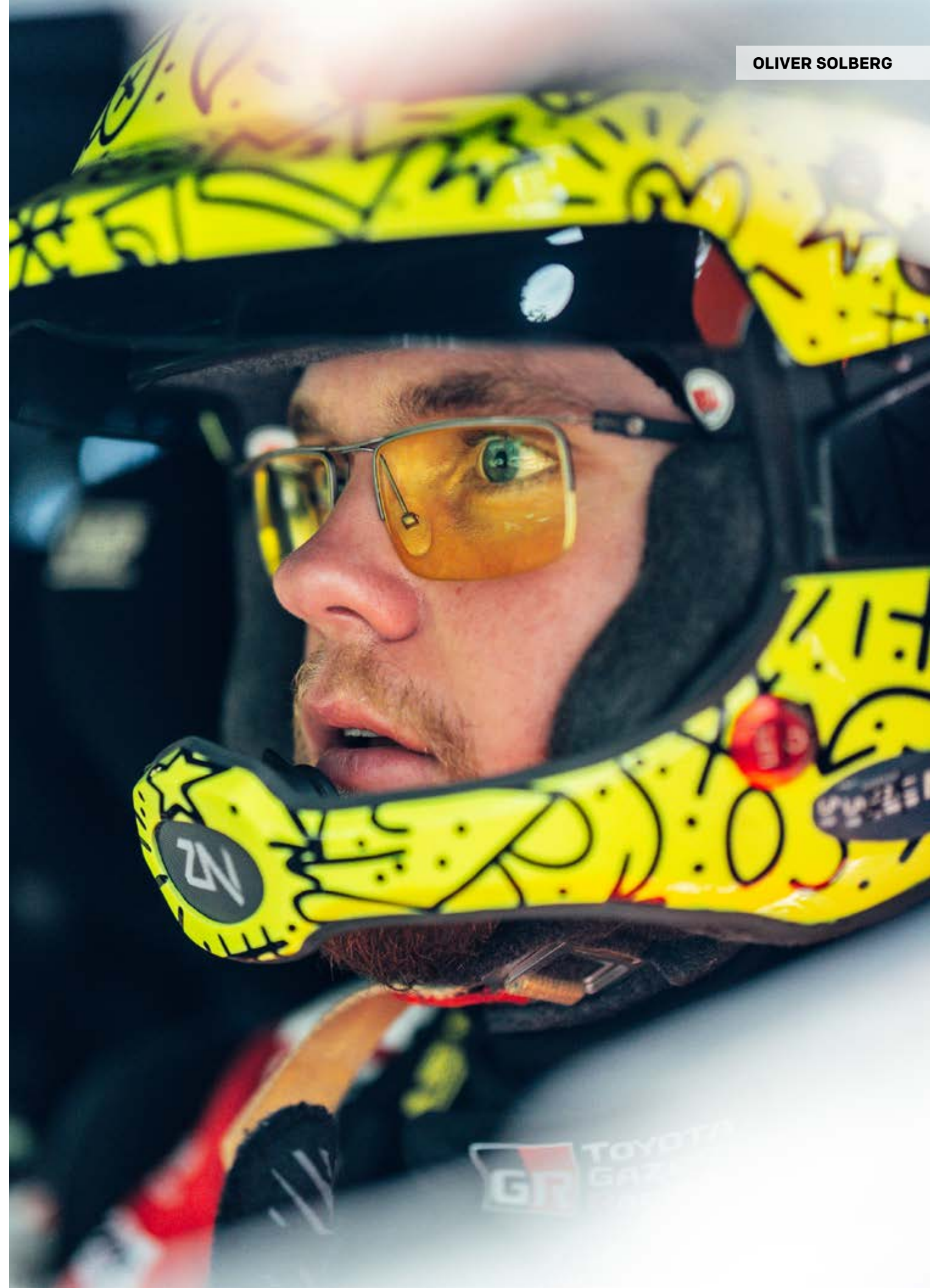

# FEARLESS

DIGITAL AMPLIFIER FOR RALLY USE

125 x 70 x 35 mm

6100046

€ 425,00 (Z)

The FEARLESS Digital Amplifier has been completely re-engineered to a rugged, IP65-rated device designed for motorsport environments, offering superior dust and water protection. It features a 36% larger display for better visibility, a silicone keyboard for reliable tactile feedback, and panel-mounted Nexus connectors for enhanced durability. Powered by a digital processor with ClearVoice™ technology, it reduces background noise and it isolates the voice. Users can adjust audio settings and fine-tune parameters remotely via the ZeroNoise App. It is compatible with Bell helmets, ZeroNoise headsets, and other Nexus-based systems.

## FEATURES

- Clearvoice(TM) technology with adaptive noise cancelling and voice isolation
- Multifunction touch display (It works with gloves)
- Bluetooth
- Anti shock, anti vibration silicon cover
- Dual volume adjustment
- Easy fix system on roll bar or dashboard
- IP67 connectors for protection and easy replacement
- CAN-Bus integration with the car's control system
- Full Wi-Fi control from smartphone or tablet

## INCLUDED IN THE BOX

- Audio Out for car camera
- Audio IN/OUT radio connection
- 12V Filtered power cable
- CAN-BUS

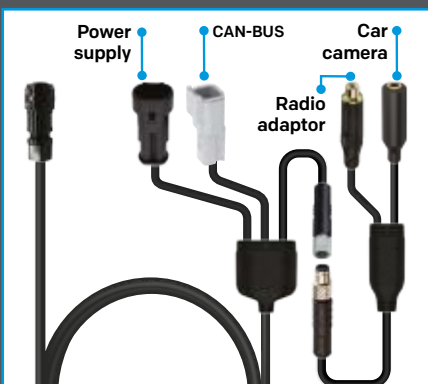

## NEXUS CONNECTOR



## CLEARVOICE™



## DRIVER/CO-DRIVER CABLE NOT INCLUDED WITH AMPLIFIER

|   |   |  |
|---|---|--|
| <p><b>6100050</b> € 60,00 (Z)</p> <p>You need to buy 2 cables (Driver and CO-driver)</p> <p>Connector: Male 4 PIN Nexus</p> | <p><b>6100051</b> € 60,00 (Z)</p> <p>You need to buy 2 cables (Driver and CO-driver)</p> <p>Connector: Female 4 PIN Nexus</p> | <p><b>6100052</b> € 60,00 (Z)</p> <p>You need to buy 2 cables (Driver and CO-driver)</p> <p>Connector: (comp. IMSA) Female 4 PIN Nexus</p> |
|---|---|--|

CABLE DETAILS PAGE 206

# FEARLESS

WRC CAN-BUS

PRO DIGITAL AMPLIFIER FOR RALLY USE

180 x 140 x 45 mm

6100036

€ 1.250,00 (Z)

FEARLESS WRC Can-Bus is a professional solution for the most demanding teams and drivers. The intercom features two units inside the box for full reliability, the second being a back up unit that exactly replicates the first one. The Can-bus interface provides full accessibility to the intercoms commands on the dashboard of the car, therefore FEARLESS WRC Can-Bus can be placed anywhere in the car where it is more convenient. The audio performance is the one of the Fearless standard and it integrates Clearvoice™ technology for noise cancelling and voice isolation and enhancement. On the outside, there are Deutsch connectors to ensure compliance to a motorsport standard.

## NEXUS CONNECTOR



Cable to driver (2m)

Cable to co-driver (2m)

12V cable to car battery + Audio out for car camera + Audio in for radio + CAN-BUS

## DRIVER/CO-DRIVER CABLE NOT INCLUDED WITH AMPLIFIER

**6100037** € 460,00 (Z)

Wires and Deutsch connectors from the Fearless WRC CanBus amplifier to the car.



# FURY OFFROAD

DIGITAL AMPLIFIER FOR RALLY USE

125 x 70 x 35 mm

6100045

€ 275,00 (Z)

FURY combines the digital sound quality with the simplicity of use. It integrates Clearvoice™ technology for voice isolation in a simple ready-to-use package that has been upgraded with IP protection from water and dust for Offroad use. The four pre-set buttons had been carefully designed to refine the sound in any condition. They both work independently or combined. TERRAIN: The noise cancelling algorithm focusses on the noises coming from the road surface. BOOST: It enhances the voice volume output for the most demanding drivers. ENGINE: This pre-set is effective on the noises coming from the engine. ROAD/STAGE: Stage mode turns off the radio output, so the communication is solely between drive and co-driver for maximum focus.

## FEATURES

- Clearvoice(TM) technology with adaptive noise cancelling and voice isolation
- Anti shock, anti vibration silicon cover
- Dual volume adjustment
- Easy fix system on roll bar or dashboard
- Remote firmware upgrades via Wi-Fi
- IP67 connectors for protection and easy replacement
- CAN-Bus integration with the car's control system
- Full Wi-Fi control from smartphone or tablet
- Sound presets for terrain and engine noise
- Boost function for clearer voice levels

## INCLUDED IN THE BOX

- Audio Out for car camera
- Audio IN/OUT radio connection
- 12V Filtered power cable
- CAN-BUS

## NEXUS CONNECTOR



## CLEARVOICE™



Cable to driver (2m)  
Cable to co-driver (2m)  
12V cable to car battery + Audio out for car camera + Audio in/out for radio

## DRIVER/CO-DRIVER CABLE NOT INCLUDED WITH AMPLIFIER

|   |   |   |
|---|---|---|
| 6100050 € 60,00 (Z)                             | 6100051 € 60,00 (Z)                             | 6100052 € 60,00 (Z)                             |
| You need to buy 2 cables (Driver and CO-driver) | You need to buy 2 cables (Driver and CO-driver) | You need to buy 2 cables (Driver and CO-driver) |
|   |   |   |
| Connector: Male 4 PIN Nexus                     | Connector: Female 4 PIN Nexus                   | Connector: (comp. IMSA) Female 4 PIN Nexus      |

CABLE DETAILS PAGE 206

# FEARLESS OFFROAD

DIGITAL AMPLIFIER FOR RALLY USE

125 x 70 x 35 mm

6100047

€ 505,00 (Z)

The FEARLESS OFFROAD amplifier includes all the features of the standard Fearless with enhanced water and dust resistance for use in demanding environments. It does not include Bluetooth, or any external connectivity as these features had been disabled at the factory to meet specific regulations. Each unit comes with a Factory Certificate to confirm full compliance with the relevant standards.

## FEATURES

- Clearvoice(TM) technology with adaptive noise cancelling and voice isolation
- Multifunction touch display (It works with gloves)
- External connectivities disabled by the factory
- Anti shock, anti vibration silicon cover
- Dual volume adjustment
- Easy fix system on roll bar or dashboard
- IP67 connectors for protection and easy replacement
- CAN-Bus integration with the car's control system

## INCLUDED IN THE BOX

- Audio Out for car camera
- Audio IN/OUT radio connection
- 12V Filtered power cable
- CAN-BUS

## NEXUS CONNECTOR



## CLEARVOICE™



Cable to driver (2m)  
Cable to co-driver (2m)  
12V cable to car battery + Audio out for car camera + Audio in/out for radio

## DRIVER/CO-DRIVER CABLE NOT INCLUDED WITH AMPLIFIER

|   |   |   |
|---|---|---|
| 6100050 € 60,00 (Z)                             | 6100051 € 60,00 (Z)                             | 6100052 € 60,00 (Z)                             |
| You need to buy 2 cables (Driver and CO-driver) | You need to buy 2 cables (Driver and CO-driver) | You need to buy 2 cables (Driver and CO-driver) |
|   |   |   |
| Connector: Male 4 PIN Nexus                     | Connector: Female 4 PIN Nexus                   | Connector: (comp. IMSA) Female 4 PIN Nexus      |

CABLE DETAILS PAGE 206

# FURY

DIGITAL AMPLIFIER FOR RALLY USE

125 x 70 x 35 mm

6100038 to 6100040 € 295,00 (Z)

FURY is the digital amplifier that makes the incomparable quality of Zeronoise adaptive noise cancelling available to all drivers. FURY combines the digital sound quality with the simplicity of use. The four pre-set buttons had been carefully designed to refine the sound in any condition. They both work independently or combined.

**TERRAIN:** The noise cancelling algorithm focusses on the noises coming from the road surface.

**BOOST:** It enhances the voice volume output for the most demanding drivers.

**ENGINE:** This pre-set is effective on the noises coming from the engine.

**ROAD/STAGE:** Stage mode turns off the radio output, so the communication is solely between drive and co-driver for maximum focus.

## FEATURES

- Adaptive noise cancelling
- Anti shock, anti vibration silicon cover
- Software updates through USB-C port
- Audio Out for car camera
- Audio IN/OUT radio connection
- Dual volume adjustment
- 12V Filtered power cable
- Easy fix system on roll bar or dashboard
- Available with three different connectors:
  - Male 4 PIN Nexus
  - Female 4 PIN Nexus
  - Female 4 PIN Nexus (comp. IMSA)

FURY DIGITAL AMPLIFIER IS AVAILABLE WITH THESE CONNECTORS

Amplifier with male 4 pin nexus connectors **6100038**



Amplifier with female 4 pin nexus connectors **6100039**



Amplifier with female 4 pin nexus connectors (comp. IMSA) **6100040**



## NEXUS CONNECTOR



FIXING BRACKET

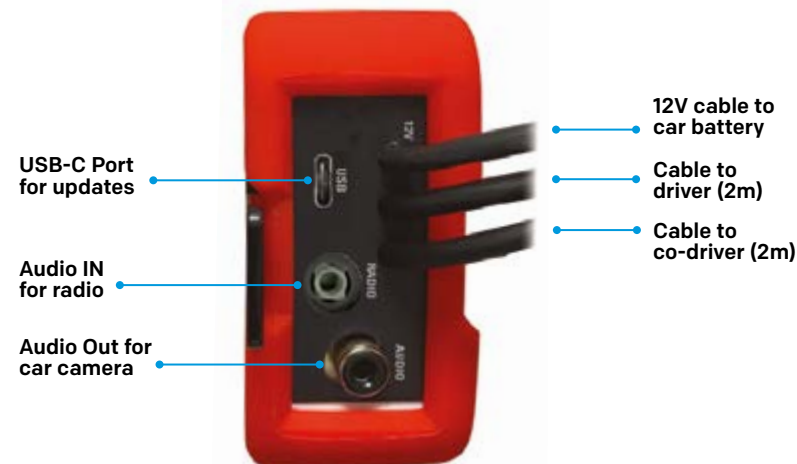

# BRAVE

ANALOG AMPLIFIER FOR RALLY USE

125 x 70 x 35 mm

6100002 to 6100004 € 189,00 (Z)

BRAVE is ZERONOISE analog amplifier with a unique value for money. Its brand new amplification delivers a clean sound with the likes of professional intercoms and endless power. It also features a 12v power cable to connect BRAVE to the car battery and a car camera RCA socket. It is fully compatible with all ZERONOISE INTERCOM KITS/HEADSETS.

## FEATURES

- Analog noise filter
- Efficient amplification for long battery life
- Anti shock, anti vibration silicon cover
- Easy fix system on roll bar or dashboard
- 9V Internal battery and 12V power cable
- Dual volume adjustment
- ON/OFF led light
- Audio Out for car camera
- Available with three different connectors:
  - Male 4 PIN Nexus
  - Female 4 PIN Nexus
  - Female 4 PIN Nexus (comp. IMSA)

BRAVE ANALOG AMPLIFIER IS AVAILABLE WITH THESE CONNECTORS

Amplifier with male 4 pin nexus connectors **6100002**



Amplifier with female 4 pin nexus connectors **6100003**



Amplifier with female 4 pin nexus connectors (comp. IMSA) **6100004**



## NEXUS CONNECTOR



FIXING BRACKET

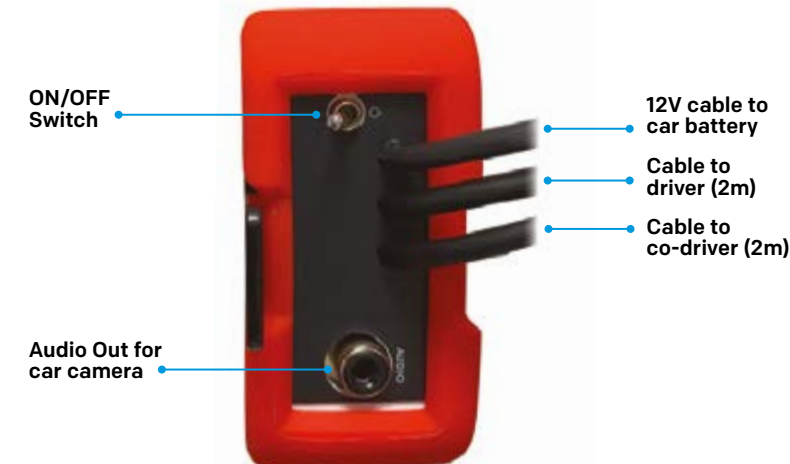

# HEADSET

PROFESSIONAL HEADSET FOR RALLY USE

6200002 to 6200004 € 195,00 (Z)

ZERONOISE HEADSET provides high hearing protection while being comfortable and lightweight. The high efficiency speakers are suitable for a conversation or listening to music. It also features a dynamic noise cancelling microphone and an adjustable flex boom.

Compatible with all Zeronoise amplifier with nexus connector.

## FEATURES

- High efficiency speakers for music or voice
- Dynamic noise cancelling microphone
- Flex boom to adjust microphone
- High hearing protection
- Soft auto adjustable headband
- Comfortable earpads
- Coiled cable
- Available with three different connectors:
  - Male 4 PIN Nexus
  - Female 4 PIN Nexus
  - Female 4 PIN Nexus (comp. IMSA)

## HEADSET IS AVAILABLE WITH THESE CONNECTORS

Headset with male 4 pin nexus connectors **6200002**



Headset with male 4 pin nexus connectors **6200003**



Headset with male 4 pin nexus connectors (comp. IMSA) **6200004**



## NEXUS CONNECTOR



# VALIANT

CLUB AMPLIFIER FOR RALLY USE

135 x 65 x 30 mm

6100029 € 89,00 (Z)

VALIANT is the entry level analog amplifier of ZERONOISE. It is easy to use, solid and straightforward, a good choice for amateurs and beginners. It is powered by the internal 9v battery, or the 12v power cable that connects VALIANT directly to the car battery. It also features 6.35mm connectors and car camera RCA socket for audio output.

## FEATURES

- Analog noise filter
- Efficient amplification for long battery life
- Anti shock, anti vibration silicon cover
- Dual volume adjustment
- 9V Internal battery and 12V power cable
- ON/OFF led light
- Audio Out for car camera
- Easy fix system on roll bar or dashboard

## AVAILABLE CONNECTOR

Amplifier with Female stereo 6.35 mm **6100029**



## STEREO CONNECTOR

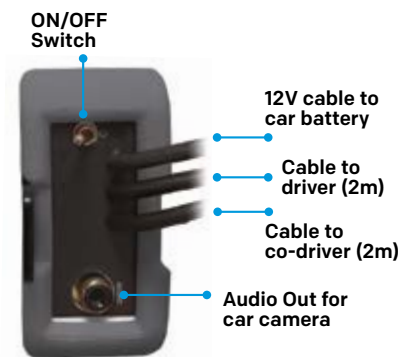

## STEREO CONNECTOR



# VALIANT HEADSET

DIGITAL AMPLIFIER FOR RALLY USE

6200001 € 145,00 (Z)

- With Electret Noise Cancelling microphone
- Male Jack 6.35mm STEREO connector and coiled cable

## AVAILABLE CONNECTOR

Amplifier with male 4 pin nexus connectors **6200001**



## COMMUNICATION SYSTEM

The Circuit Systems enable communication between the car and the pit with a standard phone call, through a professional intercom system connected via bluetooth to the smartphone, as well as in-car communication between driver and co-driver/instructor. PIT LINK allows you to connect up to two people in the car, as well as more cars and more people at the pit by using the conference call feature of the smartphone.

## COMPONENTS

- Pit link GSM amplifier
- Helmet radio kits
- Headsets for driver or co driver
- Extensions and adaptors (if needed for different connector systems, e.g. components produced by other manufacturers)
- Pit Link headset for the pit crew
- PTT button for call

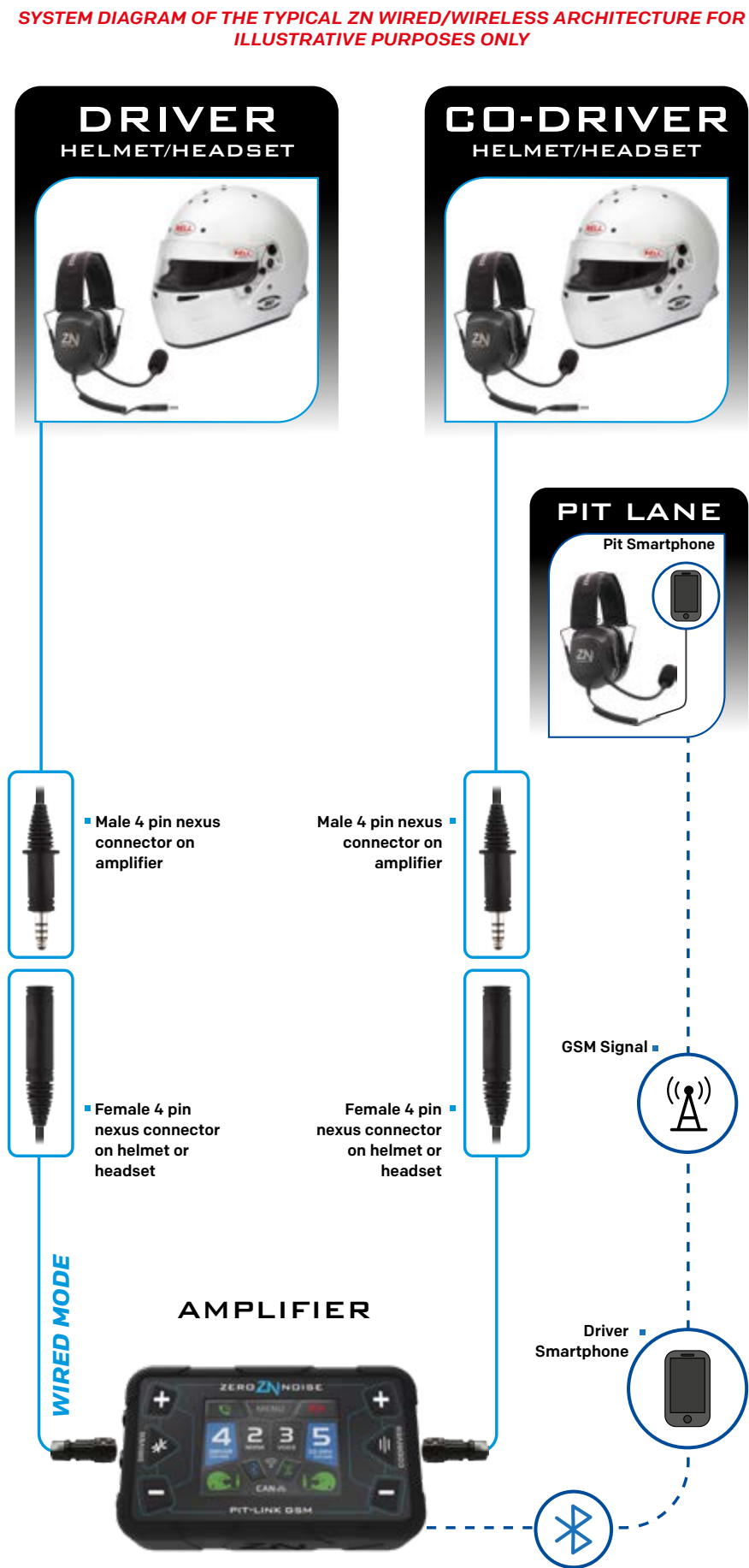

- PLEASE READ THE INSTRUCTIONS CAREFULLY BEFORE USING -



# PIT-LINK

DIGITAL AMPLIFIER FOR CIRCUIT USE

125 x 70 x 35 mm

6100048

€ 555,00 (Z)

The PIT-LINK Amplifier is a fully redesigned communication system for circuit. The system supports a GSM phone call through Bluetooth connectivity for simultaneous (duplex) car-to-pit communications, activated automatically or via a push-to-talk button. It is the alternative to a traditional VHF/UHF radio with no need of licenses and repeaters. It features a 36% larger display, a silicone keyboard for reliable tactile feedback, and durable panel-mounted connectors. At its core, ClearVoice™ technology isolates and enhances voice clarity, with adjustable settings. Additional features include RCA output for cameras, radio connection, and a 12V power cable.

## FEATURES

- Digital active noise filtering
- Multifunction touch display (with gloves)
- Bluetooth as a car-to-pit communication tool
- Anti shock, anti vibration silicon cover
- Dual volume adjustment
- Easy fix system on roll bar or dashboard
- IP67 connectors for protection and easy replacement
- CAN-Bus integration with the car's control system
- Full Wi-Fi control from smartphone or tablet

## CABLE INCLUDED

- Audio Out for car camera
- Audio IN/OUT radio connection
- 12V Filtered power cable
- PTT button
- CAN BUS

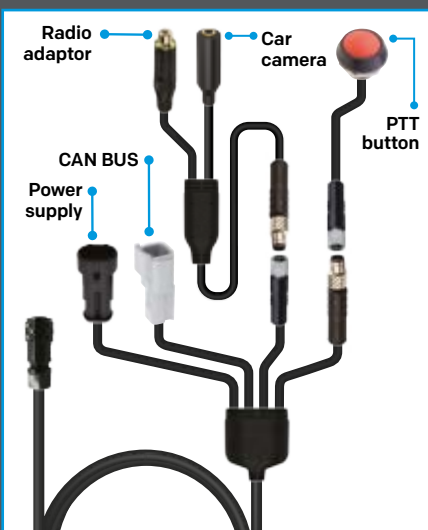

## NEXUS CONNECTOR



## CLEARVOICE™



Cable to driver (2m)

Cable to co-driver (2m)

12V cable to car battery + Audio out for car camera + Audio in/out for radio + PTT + CAN BUS

## DRIVER/CO-DRIVER CABLE NOT INCLUDED WITH AMPLIFIER

| 6100050   | € 60,00 (Z) | 6100051   | € 60,00 (Z) | 6100052   | € 60,00 (Z) |
|---|-------------|---|-------------|---|-------------|
| You need to buy 2 cables (Driver and CO-driver) |             | You need to buy 2 cables (Driver and CO-driver) |             | You need to buy 2 cables (Driver and CO-driver) |             |
|   |             |   |             |   |             |
| Connector: Male 4 PIN Nexus                     |             | Connector: Female 4 PIN Nexus                   |             | Connector: (comp. IMSA) Female 4 PIN Nexus      |             |

CABLE DETAILS PAGE 206

# PIT HEADSET

PROFESSIONAL HEADSET FOR CIRCUIT USE

6200005 to 6200006

€ 275,00 (Z)

PIT-LINK HEADSET provides high hearing protection while being comfortable and lightweight. It is ideal to be used at the pit thanks to the dynamic noise cancelling microphone and an adjustable flex boom, and PTT button

## FEATURES

- Professional Headset with Noise cancelling
- Jack 3.5mm connector for smartphone
- PTT Button

## AVAILABLE CONNECTORS WITH PIT-LINK HEADSET

Jack 3.5mm- Smartphone comp. WITH PTT BUTTON ANDROID compatible **6200005**



Jack 3.5mm- Smartphone comp. WITH PTT BUTTON IPHONE compatible **6200006**



## PHONE CONNECTOR

# EARPLUGS KIT

PROFESSIONAL EARPLUGS FOR CIRCUIT USE

The new ZN PRO EARPLUGS feature a super soft, very comfortable silicone moulded shape that easily adapts to any ear.

The speaker is mounted in the ear canal that can be short or long, depending on the ear shape and personal preferences.

## PRO EARPLUGS SHORT KIT

Semicustom earplugs with short ear canal (3.5mm Male Connector)



Semicustom earplugs with short ear canal (3.5mm Male Connector)



## PRO EARPLUGS LONG KIT

Semicustom earplugs with long ear canal (3.5mm Male Connector) Mono / Stereo adaptor included



Semicustom earplugs with long ear canal and cleaning kit (RCA Male Connector)



## EARPLUGS FOAM KIT

Earplugs kit with foam tips 3.5mm Male Connector



Earplugs kit with foam tips RCA Male Connector



Cleaning kit included with Pro earplugs kit

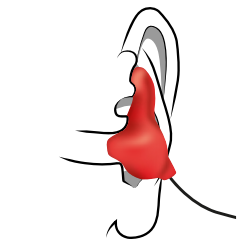

Earplugs short ear canal

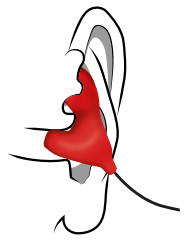

Earplugs long ear canal



# EARCUPS

Connector: RCA Male CINCH CONNECTOR



Connector: 3.5mm STEREO PLUG



RADIO CONNECTOR

# RADIO HEADSET

PROFESSIONAL HEADSET FOR CIRCUIT USE

6200011

€ 195,00 (Z)

RADIO HEADSET 5 PIN MINI-XLR - PTT provides high hearing protection while being comfortable and lightweight. It is ideal to be used at the pit thanks to the dynamic noise cancelling microphone and an adjustable flex boom, and PTT button.

It is fully compatible with all the radio connection wirings 6400032/6400041

## FEATURES

- High efficiency speakers
- Dynamic noise cancelling microphone
- Flex boom to adjust microphone
- High hearing protection
- Soft auto adjustable headband
- Comfortable earpads
- PTT button
- Wide range of connectors compatible with the most common radio on the market

## AVAILABLE CABLE NOT INCLUDED WITH PROFESSIONAL RADIO HEADSET

|   |   |   |
|---|---|---|
| <p><b>6400032</b> € 89,00 (Z)</p> <p>Connector: M-5C mini XLR Motorola</p>      | <p><b>6400033</b> € 89,00 (Z)</p> <p>Connector: M4-5C mini XLR Motorola</p> | <p><b>6400034</b> € 89,00 (Z)</p> <p>Connector: M2-5C mini XLR Motorola</p> |
| <p><b>6400035</b> € 89,00 (Z)</p> <p>Connector: M7-5C mini XLR Motorola</p>     | <p><b>6400036</b> € 89,00 (Z)</p> <p>Connector: K-5C mini XLR Kenwood</p>   | <p><b>6400037</b> € 89,00 (Z)</p> <p>Connector: K1-5C mini XLR Kenwood</p>  |
| <p><b>6400038</b> € 89,00 (Z)</p> <p>Connector: I2-5C mini XLR ICOM</p>         | <p><b>6400039</b> € 89,00 (Z)</p> <p>Connector: S2-5C mini XLR ICOM</p>     | <p><b>6400040</b> € 89,00 (Z)</p> <p>Connector: I-5C mini XLR ICOM</p>      |
| <p><b>6400041</b> € 89,00 (Z)</p> <p>Connector: Y2-5C mini XLR VERTEX/YAESU</p> |   |   |

PIT-LINK TRAINER is the micro amplifier designed to be the perfect communication tool for karting. PIT-LINK TRAINER is a Bluetooth Digital Amplifier that allows to communicate with the pit during a training session. You can wear it around your neck and keep it inside your suit. The digital noise cancelling makes the communication smooth by reducing the noise around the driver. Communication is automatically on when the phone call is incoming. No need to press anything. The pit crew will connect to the driver through a normal phone call. PIT-LINK TRAINER requires PIT-LINK MICROPHONE KIT and PIT-LINK EARPLUGS to be setup in the helmet.

## AMPLIFIER-KART BASIC KIT FOR DRIVER

6100033

€ 320,00 (Z)



Wearable amplifier

USB-C microphone radio kit

Professional earplugs

## PIT HEADSET

### HEADSET COMPATIBLE

Jack 3.5mm Smartphone comp. WITH PTT BUTTON - ANDROID compatible

6200005

€ 275,00 (Z)

Jack 3.5mm- Smartphone comp. WITH PTT BUTTON - iPHONE compatible

6200006

€ 275,00 (Z)

USB-C wearable amplifier compatible WITH PTT BUTTON (not for smartphone)

6200007

€ 360,00 (Z)



- Professional Headset with Noise cancelling
- Microphone Jack 3.5mm connector for smartphone.
- PTT Button

## EARPLUGS KIT

- Earplugs with smartphone male jack 3.5mm connector
- Spare set of super soft foam tips
- Metal case

6400021

€ 99,00 (Z)



## RHK

- Radio helmet kit for full face helmet - USB-connector for pit-link trainer
- With 3.5mm stereo connector for earplugs

6300026

€ 135,00 (Z)

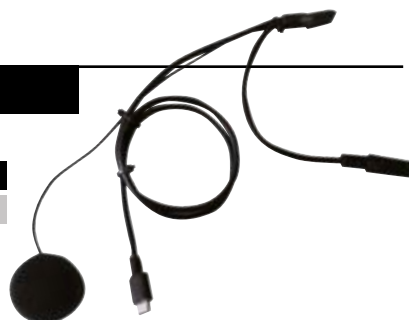

## WEARABLE AMPLIFIER

Micro Amplifier Super Fast Bluetooth Advanced Noise cancelling USB Port (Type C) for recharging Independent volume Long life rechargeable Internal battery USB-C recharging cable included

6100031

€ 165,00 (Z)



## PIT-LINK TRAINER SYSTEM ARCHITECTURE

### EXAMPLE USING 2 WEARABLE AMPLIFIERS

PRO KIT 6100024



### EXAMPLE USING 1 WEARABLE AMPLIFIERS

PRO KIT 6100032 6100034



## AMPLIFIER-KART PRO KIT

### WITH USB-C WEARABLE AMPLIFIER COMPATIBLE HEADSET

the kit includes 2 amplifier: one for driver, one for pit

6100024

€ 615,00 (Z)



Wearable amplifier

USB-C microphone radio kit

Professional earplugs



PIT

Wearable amplifier

Headset

### KIT WITH IPHONE COMPATIBLE HEADSET JACK 3.5 MM

6100034 € 540,00 (Z)

### KIT WITH ANDROID COMPATIBLE HEADSET JACK 3.5 MM

6100032 € 540,00 (Z)



Wearable amplifier

USB-C microphone radio kit

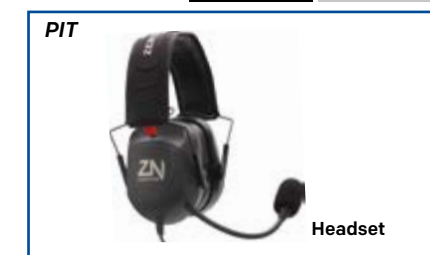

Professional earplugs









PIT

Headset

All our radio kits in a single table. Here you can find all the radio kits we have developed for an optimised use with ZN amplifiers, and still compatible with the major competitors' products.

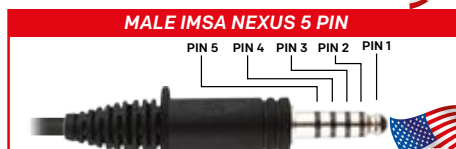
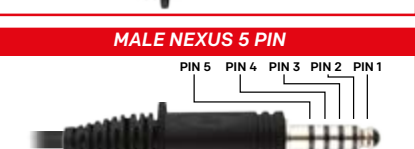
| YOUR HELMET MODEL  | PRICE        | REF.   | BELL HELMETS COMPATIBLE                             | CONNECTOR                |
|--|--------------|--|---|--------------------------|
| <br><b>OPEN FACE HELMET</b>  | €205,00 (Z)  | 6300001                                      | MAG-10 RALLY SPORT / X-1 RALLY                      | FEMALE NEXUS 4 PIN       |
|  | € 80,00 (Z)  | 6300002                                      | MAG RALLY / OMP J-RALLY                             | FEMALE NEXUS 4 PIN       |
|  | € 205,00 (Z) | 6300003                                      | HP10 RALLY/MAG-10 RALLY PRO/MAG-10 RALLY CARBON     | FEMALE NEXUS 4 PIN       |
|  | € 205,00 (Z) | 6300040                                      | MAG-10 RALLY PRO, CARBON - 2025                     | FEMALE NEXUS 4 PIN       |
|  | € 205,00 (Z) | 6300004                                      | MAG-10 RALLY SPORT / X-1 RALLY                      | MALE NEXUS 4 PIN         |
|  | € 85,00 (Z)  | 6300005                                      |   | MALE NEXUS 4 PIN         |
|  | € 205,00 (Z) | 6300006                                      | MAG-10 RALLY SPORT / X-1 RALLY                      | MALE IMSA NEXUS 4 PIN    |
|  | € 85,00 (Z)  | 6300007                                      | GT6 WHITE 4C/SP / MAG-1 RALLY (With IMSA Radio kit) | MALE IMSA NEXUS 4 PIN    |
|  | € 35,00 (Z)  | 6300008                                      |   | MALE STEREO 6.35 mm      |
|  | € 185,00 (Z) | 6300024                                      | HELMET SERIES 3, 6, 7, 10, 77                       | MALE NEXUS 4 PIN         |
| € 185,00 (Z)   | 6300025      | HELMET SERIES 3, 6, 7, 10, 77                | MALE NEXUS 4 PIN                                    |                          |
| <br><b>FULL FACE HELMET</b> | € 205,00 (Z) | 6300009                                      | HELMET SERIES GT6, HP6                              | MALE NEXUS 4 PIN         |
|  | € 85,00 (Z)  | 6300010                                      |   | MALE NEXUS 4 PIN         |
|  | € 185,00 (Z) | 6300011                                      | HELMET SERIES 3, 6, 7, 77                           | MALE NEXUS 4 PIN         |
|  | € 185,00 (Z) | 6300012                                      | HELMET SERIES 3, 6, 7, 77                           | MALE NEXUS 4 PIN         |
|  | € 205,00 (Z) | 6300013                                      | HELMET SERIES 3, 6, 7, 77                           | MALE NEXUS 5 PIN         |
|  | € 205,00 (Z) | 6300014                                      | HELMET SERIES GT6, HP6                              | MALE IMSA NEXUS 4 PIN    |
|  | € 85,00 (Z)  | 6300015                                      |   | MALE IMSA NEXUS 4 PIN    |
|  | € 185,00 (Z) | 6300016                                      | HELMET SERIES 3, 6, 7, 77                           | MALE IMSA NEXUS 4 PIN    |
|  | € 185,00 (Z) | 6300017                                      | HELMET SERIES 3, 6, 7, 77                           | MALE IMSA NEXUS 4 PIN    |
|  | € 205,00 (Z) | 6300018                                      | HELMET SERIES 3, 6, 7, 77                           | MALE IMSA NEXUS 5 PIN    |
|  | € 35,00 (Z)  | 6300019                                      |   | MALE STEREO 6.35 mm      |
|  | € 85,00 (Z)  | 6300023                                      |   | FEMALE NEXUS 4 PIN       |
|  | € 135,00 (Z) | 6300026                                      | HELMET SERIES CMR, K                                | USB-C FOR PIT LINK       |
|  | € 205,00 (Z) | 6300027                                      | HELMET SERIES GT6, HP6                              | FEMALE NEXUS 4 PIN       |
|  | € 79,00 (Z)  | 6300034                                      | HELMET SERIES GT6, HP6                              | MALE RCA                 |
|  | € 79,00 (Z)  | 6300035                                      | HELMET SERIES GT6, HP6                              | MALE STEREO 3.5 mm       |
|  | € 205,00 (Z) | 6300036                                      | HP10 RALLY WW*-MAG-10 RALLY WW CARBON*              | NEXUS CONN. NOT INCLUDED |
|  | € 185,00 (Z) | 6300037                                      | HELMET SERIES 3, 6, 7, 77                           | FEMALE NEXUS 4 PIN       |
|  | € 185,00 (Z) | 6300038                                      | HELMET SERIES 3, 6, 7, 77                           | FEMALE NEXUS 4 PIN       |
| € 95,00 (Z)  | 6300039      | PORTABLE EMERGENCY KIT - UNIVERSAL COMPATIB. | FEMALE NEXUS 4 PIN                                  |                          |

| CONNECTORS  |   |  |
|---|---|--|
| <b>FEMALE NEXUS 4 PIN</b><br> | <b>MALE STEREO 6.35 mm</b><br> | <b>MALE IMSA NEXUS 4 PIN</b><br> |
| <b>MALE NEXUS 4 PIN</b><br>   | <b>USB-C FOR PIT-LINK</b><br>  | <b>MALE IMSA NEXUS 5 PIN</b><br> |
| <b>MALE NEXUS 5 PIN</b><br>   | <b>MALE RCA</b><br>            | <b>MALE STEREO 3.5 mm</b><br>    |

There are 8 models for jet helmets and 12 models for full face helmets, choose yours by: **CONNECTOR**, **MICROPHONE**, **SPEAKERS**  
 Custom kit available upon request.

|                | MICROPHONE |           | CONNECTOR FOR EARPLUGS |                     | SPEAKERS     |
|----------------|------------|-----------|------------------------|---------------------|--------------|
|                | FLEX BOOM  |           |                        |                     | EARCUPS      |
|                | FLEX BOOM  |           |                        |                     | SPEAKER PADS |
| HCB COMPATIBLE |            |           |                        |                     | EARCUPS      |
| HCB COMPATIBLE |            |           |                        |                     | EARCUPS      |
|                | FLEX BOOM  |           |                        |                     | EARCUPS      |
|                | FLEX BOOM  |           |                        |                     | SPEAKER PADS |
|                | FLEX BOOM  |           |                        |                     | SPEAKER PADS |
|                | FLEX BOOM  |           |                        |                     | SPEAKER PADS |
|                | FLEX BOOM  |           |                        |                     | SPEAKER PADS |
|                | FLEX BOOM  |           | FEMALE RCA             |                     |              |
|                | FLEX BOOM  |           |                        | FEMALE STEREO 3,5mm |              |
|                |            | FULL FACE |                        |                     | EARCUPS      |
|                |            | FULL FACE |                        |                     | SPEAKER PADS |
|                |            | FULL FACE | FEMALE RCA             |                     |              |
|                |            | FULL FACE |                        | FEMALE STEREO 3,5mm |              |
|                |            | FULL FACE | FEMALE RCA             |                     | EARCUPS      |
|                |            | FULL FACE |                        |                     | SPEAKER PADS |
|                |            | FULL FACE | FEMALE RCA             |                     | SPEAKER PADS |
|                |            | FULL FACE |                        | FEMALE STEREO 3,5mm |              |
|                |            | FULL FACE | FEMALE RCA             |                     |              |
|                |            | FULL FACE |                        |                     | SPEAKER PADS |
|                |            | FULL FACE |                        |                     | SPEAKER PADS |
|                |            | FULL FACE |                        | FEMALE STEREO 3,5mm |              |
|                |            | FULL FACE |                        |                     | EARCUPS      |
|                |            | FULL FACE |                        |                     | EARCUPS      |
|                |            | FULL FACE |                        |                     | EARCUPS      |
|                |            | FULL FACE |                        |                     | EARCUPS      |
| HCB COMPATIBLE |            |           |                        |                     |              |
|                |            | FULL FACE | FEMALE RCA             |                     |              |
|                |            | FULL FACE |                        | FEMALE STEREO 3,5mm |              |
| HCB COMPATIBLE |            | FULL FACE |                        |                     | SPEAKER PADS |

|                | MICROPHONE |           | CONNECTOR FOR EARPLUGS                      |  | SPEAKERS     |
|----------------|------------|-----------|---|--|--------------|
| HCB COMPATIBLE | FLEX BOOM  | FULL FACE | MICROPHONE KIT FOR EARPLUGS RCA CONNECTOR   |  | EARCUPS      |
|                |            |           |   |  |              |
|                |            |           | MICROPHONE KIT FOR EARPLUGS 3,5mm CONNECTOR |  | SPEAKER PADS |
|                |            |           |   |  |              |

# COMPATIBILITY TABLE

# ADAPTORS

| HELMET/HEADSET/RADIO HELMET KIT   |                    |                   |                  |               |
|-----------------------------------|--------------------|-------------------|------------------|---------------|
| STANDARD (EU)                     |                    |                   | IMSA (USA)       |               |
| MALE NEXUS 4 PIN                  | FEMALE NEXUS 4 PIN | MALE NEXUS 5 PIN  | MALE NEXUS 4 PIN |               |
|                                   |                    |                   |                  |               |
| AMPLIFIER, INTERCOM, RADIO, PHONE |                    |                   |                  |               |
| STANDARD (EU)                     |                    |                   |                  |               |
| MALE NEXUS 4 PIN                  | 6400005            | EXTENSION 6400006 | MADE TO ORDER    | 6400008       |
| FEMALE NEXUS 4 PIN                | EXTENSION 6400006  | 6400004           | MADE TO ORDER    | 6400009       |
| FEMALE NEXUS 4 PIN                | 6400012            | 6400013           | MADE TO ORDER    | MADE TO ORDER |
| FEMALE NEXUS 4 PIN                | 6400009            | 6400007           | MADE TO ORDER    | MADE TO ORDER |
| FEMALE NEXUS 5 PIN                | NA                 | NA                | NA               | 6400014       |
| FEMALE PHONE CONN. 3.5 mm         | 6400011            | 6400010           | MADE TO ORDER    | MADE TO ORDER |

| STANDARD (EU) |        |                          |                             |                    |           |             |
|---------------|--------|--------------------------|-----------------------------|--------------------|-----------|-------------|
| ADAPTOR TYPE  | LENGHT | CONNECTOR 1              | CABLE TYPE                  | CONNECTOR 2        | REFERENCE | PRICE       |
| ADAPTOR       | 25 cm  | MALE NEXUS 4 PIN         | COILED CABLE CROSSED WIRING | MALE NEXUS 4 PIN   | 6400004   | € 72,00 (Z) |
| ADAPTOR       | 25 cm  | FEMALE NEXUS 4 PIN       | COILED CABLE CROSSED WIRING | FEMALE NEXUS 4 PIN | 6400005   | € 72,00 (Z) |
| EXTENSION     | 150 cm | MALE NEXUS 4 PIN         | COILED CABLE                | FEMALE NEXUS 4 PIN | 6400006   | € 72,00 (Z) |
| EXTENSION     | 25 cm  | MALE NEXUS 4 PIN         | COILED CABLE                | FEMALE NEXUS 4 PIN | 6400042   | € 72,00 (Z) |
| ADAPTOR       | 25 cm  | FEMALE NEXUS 4 PIN       | STRAIGHT CABLE              | MALE NEXUS 5 PIN   | 6400012   | € 85,00 (Z) |
| ADAPTOR       | 25 cm  | MALE NEXUS 4 PIN         | STRAIGHT CABLE              | MALE NEXUS 5 PIN   | 6400013   | € 85,00 (Z) |
| ADAPTOR       | 25 cm  | FEMALE NEXUS 4 PIN / RCA | COILED CABLE                | MALE NEXUS 4 PIN   | 6400021   | € 99,00 (Z) |
| ADAPTOR       | 25 cm  | MALE NEXUS 4 PIN / RCA   | COILED CABLE CROSSED WIRING | MALE NEXUS 4 PIN   | 6400022   | € 99,00 (Z) |
| ADAPTOR       | 25 cm  | FEMALE NEXUS 4 PIN / RCA | COILED CABLE CROSSED WIRING | FEMALE NEXUS 4 PIN | 6400023   | € 99,00 (Z) |

| IMSA (USA)   |        |                           |                             |                         |           |             |
|--------------|--------|---------------------------|-----------------------------|-------------------------|-----------|-------------|
| ADAPTOR TYPE | LENGHT | CONNECTOR 1               | CABLE TYPE                  | CONNECTOR 2             | REFERENCE | PRICE       |
| ADAPTOR      | 25 cm  | FEMALE NEXUS (IMSA) 4 PIN | COILED CABLE CROSSED WIRING | FEMALE NEXUS 4 PIN      | 6400008   | € 72,00 (Z) |
| ADAPTOR      | 25 cm  | MALE NEXUS (IMSA) 4 PIN   | COILED CABLE CROSSED WIRING | FEMALE NEXUS 4 PIN      | 6400009   | € 72,00 (Z) |
| ADAPTOR      | 25 cm  | MALE NEXUS 4 PIN          | COILED CABLE CROSSED WIRING | MALE NEXUS (IMSA) 4 PIN | 6400007   | € 72,00 (Z) |
| ADAPTOR      | 25 cm  | FEMALE NEXUS (IMSA) 4 PIN | STRAIGHT CABLE              | MALE NEXUS (IMSA) 5 PIN | 6400014   | € 85,00 (Z) |

| STANDARD SMARTPHONE |        |                    |                |                                 |           |             |
|---------------------|--------|--------------------|----------------|---------------------------------|-----------|-------------|
| ADAPTOR TYPE        | LENGHT | CONNECTOR 1        | CABLE TYPE     | CONNECTOR 2                     | REFERENCE | PRICE       |
| ADAPTOR             | 50 cm  | MALE NEXUS 4 PIN   | STRAIGHT CABLE | JACK 3.5 mm MALE FOR SMARTPHONE | 6400010   | € 85,00 (Z) |
| ADAPTOR             | 50 cm  | FEMALE NEXUS 4 PIN | STRAIGHT CABLE | JACK 3.5 mm MALE FOR SMARTPHONE | 6400011   | € 85,00 (Z) |



### NEXUS CABLE CLEARVOICE

#### DRIVER/CO-DRIVER CABLE

Nexus 4 Pin Male wiring with panel connector compatible with all ZN Clearvoice Amplifiers. Length: 200 cm. (approx.)

**6100050**  
€ 60,00 (Z)

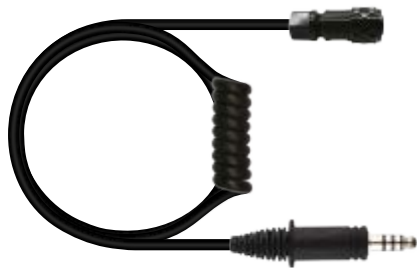

#### DRIVER/CO-DRIVER CABLE

Nexus 4 Pin Female wiring with panel connector compatible with all ZN Clearvoice Amplifiers. Length: 200 cm. (approx.)

**6100051**  
€ 60,00 (Z)



#### DRIVER/CO-DRIVER CABLE

Nexus 4 Pin Female IMSA wiring with panel connector compatible with all ZN Clearvoice Amplifiers. Length: 200 cm. (approx.)

**6100052**  
€ 60,00 (Z)



### CLEARVOICE REPLACEMENT

#### WIRING POWER SUPPLY / M5 CONNECTOR

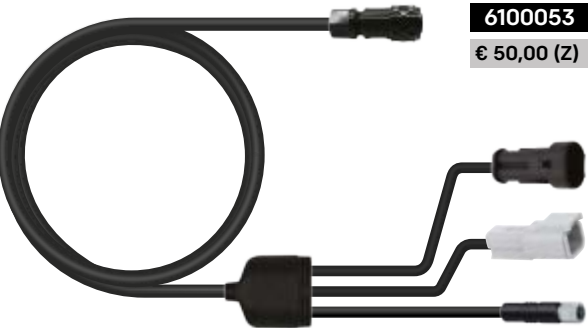

**6100053**  
€ 50,00 (Z)

#### WIRING POWER SUPPLY / M5 CONNECTOR, CANBUS

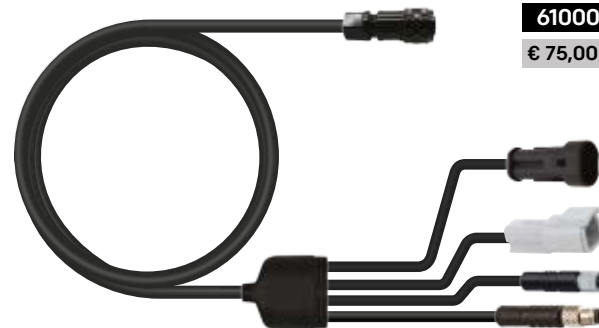

**6100055**  
€ 75,00 (Z)

#### WIRING AMPLIFIER RADIO-ADAPTOR AND CAR CAMERA



**6100054**  
€ 40,00 (Z)

#### SINGLE AND DUBLE PTT BUTTON WITH M5 CONNECTOR



**6100056**  
€ 29,00 (Z)



**6100057**  
€ 59,00 (Z)

### SILICONE COVER

#### RUGGED SILICONE COVER

Red Rugged **6100019** Black Rugged **6100030** Grey Rugged **6100035**  
€ 29,00 (Z)



#### CLEARVOICE COVER

Black Smooth CLEARVOICE amplifier cover **6100058**  
€ 25,00 (Z)



### REPLACEMENT MICROPHONE FOAM COVER

Replacement foam cover for Headset and RHK Jet Version.

**6400024**  
€ 5,00 (Z)



### REPLACEMENT TIPS

Replacement foam tips for earplugs. **6400019**  
€ 6,00 (Z)



### RHK BACKUP

Backup radio helmet kit with Female Nexus 4 Pin connector, speaker pads and microphone. Provided with a dedicated case with zip closure to store the RHK in the car. **6300039**  
€ 89,00 (Z)



### REPLACEMENTS

#### REPLACEMENT CUSHIONS

Pair of replacement head-set cushions suitable for all ZN headsets

**6400028**  
€ 12,00 (Z)



#### REPLACEMENT SPEAKER PADS

Pair of replacement speaker pads suitable for all ZN speaker pads RHK.

**6400030**  
€ 15,00 (Z)



#### REPLACEMENT EARCUPS AND CUSHIONS

Pair of replacement earcups with cushions suitable for all ZN earcups RHK.

**6400029**  
€ 32,00 (Z)



### CO-DRIVER MAP LIGHT

High efficiency led and flex metal boom, fixing bracket with switch. Length: 50 cm

**6400001**  
€ 55,00 (Z)

High efficiency led and flex metal boom, fixing bracket with switch. Length: 40 cm

**6400002**  
€ 55,00 (Z)

High efficiency led and flex metal boom, fixing bracket with switch. Length: : 30 cm

**6400003**  
€ 55,00 (Z)



### RADIO BOX

#### BOX POWER FILTER

Compatible with all amplifiers.

**6400027**  
€ 89,00 (Z)



#### BOX RADIO ADAPTER + POWER FILTER

Compatible with all amplifiers:  
FURY, FEARLESS, FEARLESS WW

**6400026**  
€ 240,00 (Z)



THIERRY NEUVILLE

### CONNECTORS

#### RUBBER CONNECTOR COVER

Rubber cover to protect nexus connection from dust and water splash.

**6400031**  
€ 15,00 (Z)



#### FEMALE CONNECTOR

Spare Female Nexus 4 Pin connecto

**6400016**  
€ 38,00 (Z)



#### MALE CONNECTOR

Spare Male Nexus 4 Pin connecto

**6400015**  
€ 27,00 (Z)

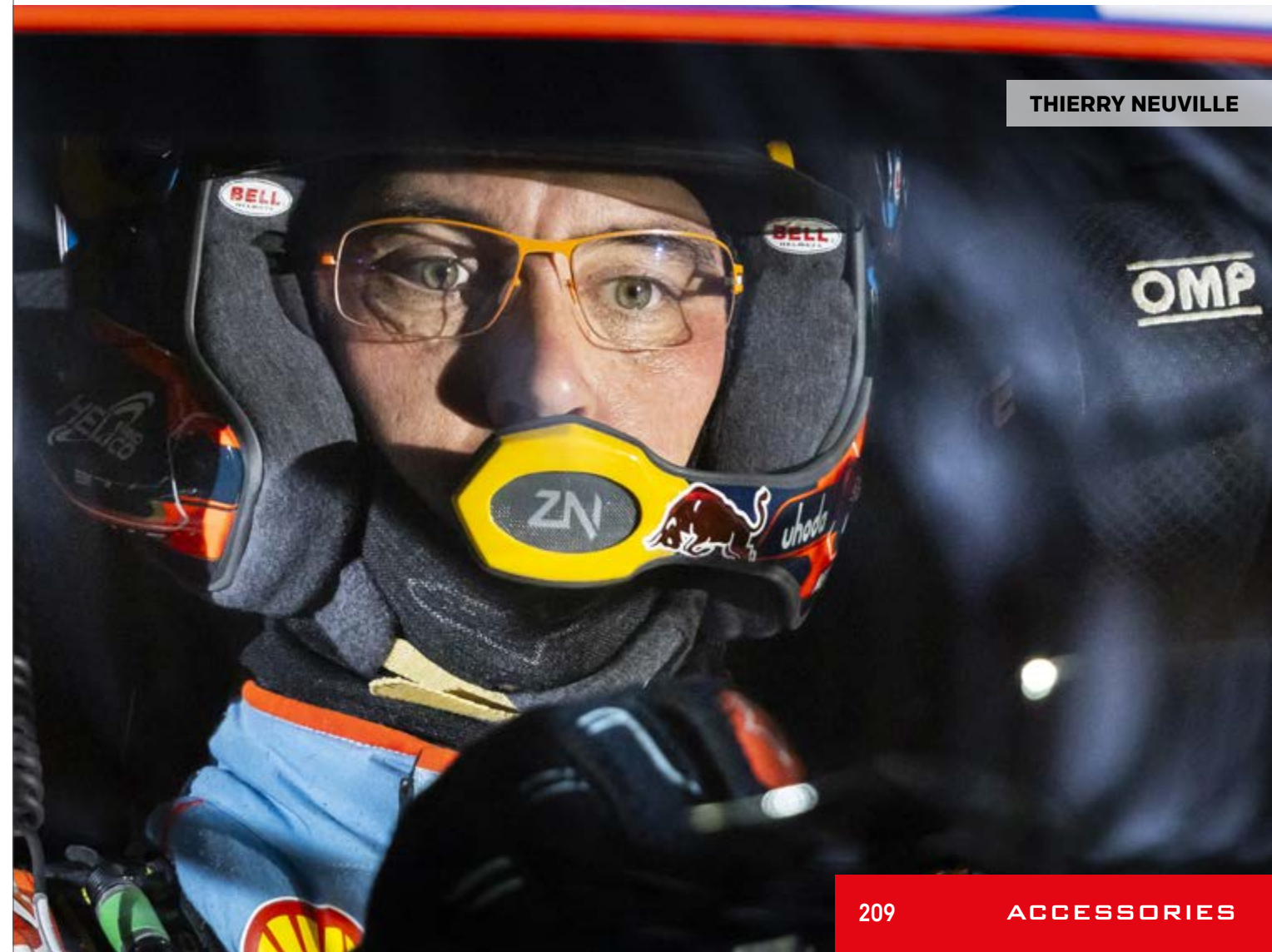



# ACCESSORIES

# RACING NETS

## RACING NET

NAO-1875 € 254,00 (C)

Professional racing net with small-sized quick release to improve driver's field of view and front strap adjustment to fit with several seat positions. Designed to be mounted on the left or on the right side of the driver.

FIA 8863-2013 homologated

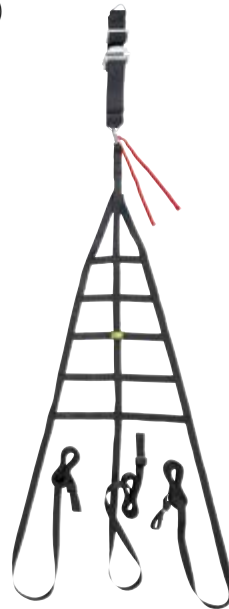

NAO-1875-A02 ON REQUEST

Professional racing net with small-sized quick release to improve driver's field of view and front strap adjustment to fit with several seat positions. Designed to be mounted on the left or on the right side of the driver.

FIA 8863-2013 homologated



## WINDOW NET

NAO-1870 € 116,00 (C)

Nylon window safety net. Black colour. Also available in red colour upon request. **Attachment:** velcro. **Dimensions webbing:** 60x60 mm **FIA J 253.11 compliant**

FIA 8863-2013 homologated

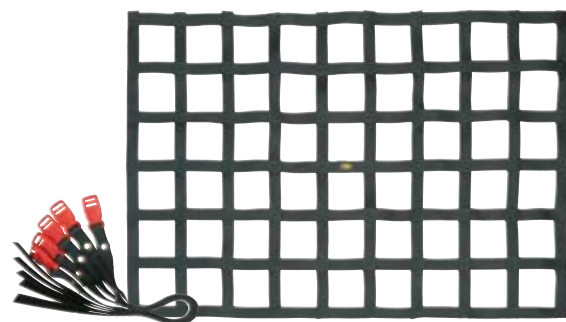

## RACING NET

NAO-1877 € 319,00 (C)

Professional top level racing net with quick release, quick front strap adjustment to fit with several seat positions, large triangle to allow an easier mounting complying FIA rules and thinner straps to improve driver's field of view. Designed to be mounted on the left or on the right side of the driver.

FIA 8863-2013 homologated

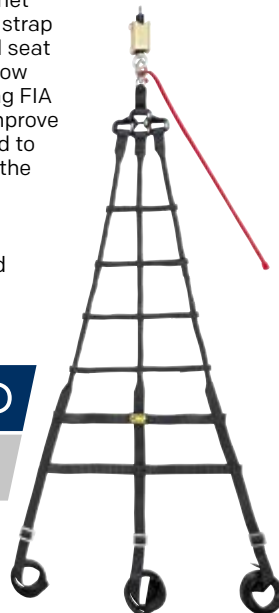

## RACING NET

NAO-1876 € 129,00 (C)

Professional entry level racing net with quick release and quick front strap adjustment to fit with several seat positions. Designed to be mounted on the left or on the right side of the driver.

FIA 8863-2013 homologated  
SFI 37.1 ON REQUEST



# ELECTRICAL ACCESSORIES

## MASTER SWITCHES (6 POLES)

FIA APPENDIX J ART. 253



EA0-0462-B01 € 43,00 (C)

6 poles with removable key disconnecting battery and alternator.

EA0-0462-B02 € 12,00 (C)

Spare key for EA/462 model.

## MASTER SWITCHES (2 POLES)

FIA APPENDIX J ART. 253



EA0-0460 € 22,00 (C)

2 poles with removable key disconnecting battery only.

EA0-0463 € 9,50 (C)

Spare key for EA/460 model.

# RACING ACCESSORIES

## HEAT PROTECTION CAR COVER

NAO-1884 € 133,00 (C)

Heat protection car cover that keep the cockpit cooler when the car is on the grid during summer and in hot places. The sides of the car cover can be lifted and locked in position, to permit the opening of the car door.



# RACING ACCESSORIES

## SPLASH GUARD

**NA0-1700-A01** Polyethylene splash guard  
Dimensions: 50x30 cm Thick: 1,5 mm

- Red  
**NA0-1700-A02-061**  
€ 23,00 (C)
- Blue  
**NA0-1700-A01-041**  
€ 23,00 (C)
- Transparent  
**NA0-1700-A01-020**  
€ 23,00 (C)



## NYLON STRAP

**NA0-1822** € 44,00 (C)

Nylon spare wheel down strap.



## WHEEL SUPPORT

**NA0-1819** € 56,00 (C)

Spare wheel support with quick release system.



## TANK TAPE

**NA0-1859** € 30,00 (C)

Tank tape. Wide: 50 mm  
Roll: 50 m

- Black  
**NA0-1859-071**
- Grey  
**NA0-1859-081**



## PRIVACY SCREEN

**NA0-1880041** € 339,00 (D)

Foldable screen to ensure safety operations privacy. It can be deployed in few seconds, four handles to hold it in position. Structure in fiberglass rib with aluminium joints, screen in airproof and waterproof nylon fabric (not fire retardant). Compact bag for transport included. SIZE (deployed): 1,8mt x 1,8mt SIZE (stored in bag): 1,4mt x 0,13mt WEIGHT: 1,9kg



## STEEL SPANNER HOLDER

**NA0-1820** € 54,00 (C)

Steel sheel spanner holder.



## SHEATH

**CD0-0324-A01** € 16,00 (C)

Fire resistant sheath.  
Ø Internal: 10mm  
Lenght: 5m.



## CROSS WHEEL SPANNER

**NA0-1821** € 76,00 (C)

Combination steel cross wheel spanner and spare wheel support.



# BONNET PINS AND TOW HOOKS

## PINS

**EB0-0489** € 36,00 (C)

Stainless steel pins with large slide pins.



## CLIPS

**EB0-0491** € 33,50 (C)

Stainless steel spring clips. Suitable for hatchbacks



## TOW HOOKS

**EB0-0571** € 26,00 (A)

Tow hook, stainless steel painted finish.  
Stud: M 12 Internal ø: 50mm Thickness: 8mm  
Complete: locking nut and washer

FIA APPENDIX J art. 253



**EB0-0576** € 27,50 (A)

Two hook, stainless steel painted finish.  
Stud: M 12 Internal ø: 80mm  
Thickness: 8mm  
Complete: locking nut and washers.

FIA APPENDIX J art. 253



## TOW HOOKS

**EB0-0572** € 49,50 (A)

Aluminium tow hook, flat.  
Thickness: 6 mm



## PINS

**EB0-0490** € 36,50 (C)

M10 aluminium pins with small sliding pins in stainless steel.



OPEN

CLOSED



## PINS

**EB0-0480** € 39,50 (C)

M10 stainless steel pins slide with large cast aluminium washers.



## STRAPS

**EB0-0487** € 39,50 (C)

Stainless steel pins with large slide pins.



## HOOKS

**EB0-0578** € 22,00 (A)

FIA APPENDIX J art. 253  
Straps. 2" ø ring: 14mm Chassis fixing: two hole 8mm and 14mm, Red only.



## BONNET PINS

**EB0-0492** € 29,50 (C)



Quick release bonnet pins aluminium W 7/16" with stainless steel hardware.

## HOOKS

**EB0-0482** € 17,50 (C)

Rubber hooks (small).



## PINS

**EB0-0483** € 25,50 (C)

Rubber hooks (large).



## HOOKS

**EB0-0580** € 31,50 (A)

FIA APPENDIX J art. 253  
Straps. 2" With restraint elastic strap. Compliant with FIA rules.



# RACING PEDALS AND FOOTRESTS

## 3 PEDALS SET

OA0-1040 € 38,00 (A)

Complete 3 pedal set with short accelerator pedal in silver anodized aluminium. Inserts: rubber anti-slip.  
**Dimens. brake:** 60x80 mm  
**Dimens. accelerator:** 60x105 mm  
 Supplied with steel bolts



## 3 PEDALS SET

OA0-1069 € 31,00 (A)

Complete 3 pedal set, in anodized aluminium and sandblasted aluminium, with long accelerator pedal; anti-slip design.  
**Dimensions brake:** 60x80 mm  
**Dimensions accelerator:** 65x180 mm  
 Colours: blue ((OA/1069/B), silver (OA/1069/A).



## 2 PEDALS SET (NO PICTURE)

OA0-1072 € 31,00 (A)

Same features of OA/1069 model with 2 pedal set with long throttle pedal; brake pedal for automatic transmission.  
**Dimens. brake:** 140x79 mm  
**Dimens. throttle:** 65x180 mm  
 Supplied with steel bolts. Colours: black (OA/1072/N), silver (OA/1072/A).

## FOOTREST

OA0-2070 € 31,00 (A)

Driver's left footrest in knurled aluminium.  
**Dimensions:** 285x120 mm



## FOOTREST

OA0-1867 € 30,00 (A)

Driver's left footrest for left foot, in sandblasted aluminium. Supplied with steel bolts and brackets.  
**Dimensions:** 260x100 mm



## FOOTREST

OA0-2060 € 75,00 (A)

Co-driver's footrest in knurled aluminium.  
**Dimensions:** 335x300 mm



## FOOTREST

OA0-1866 € 53,00 (A)

Co-driver's footrest in sandblasted aluminium. Supplied with steel bolts and brackets.  
**Dimensions:** 320x280 mm



## FOOTREST

OA0-2080 € 37,50 (A)

Universal flat footrest in knurled aluminium.  
**Dimensions:** 365x418 mm

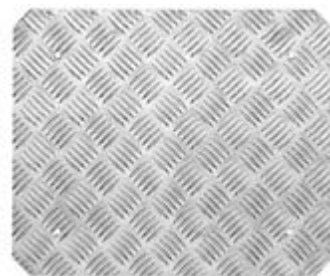

# RACING PEDALS AND FOOTRESTS

## 3 PEDALS SET

OA0-1010 € 39,00 (A)

Complete 3 pedals in sandblasted aluminium, with a long accelerator pedal. Supplied with steel bolts.  
**Dimensions brake:** 60x100 mm  
**Dimensions accelerator:** 60x210 mm



## 3 PEDALS SET

OA0-1020 € 29,00 (A)

Complete 3 pedals in sandblasted aluminium, with a long accelerator pedal. Supplied with steel bolts.  
**Dimensions brake:** 60x70 mm  
**Dimensions accelerator:** 60x210 mm



## 3 PEDALS SET

OA0-1000 € 35,00 (A)

Complete 3 pedals in sandblasted aluminium. Supplied with steel bolts.  
**Dimensions brake:** 60x100 mm  
**Dimensions accelerator:** 60x100 mm



## 3 PEDALS SET

OA0-1863 € 23,00 (A)

Complete 3 pedals in sandblasted aluminium. Supplied with steel bolts.  
**Dimensions brake:** 60x70 mm  
**Dimensions accelerator:** 85x120 mm



## 3 PEDALS SET

OA0-1030 € 24,50 (A)

Complete 3 smooth aluminium pedals, suitable for rally use, already drilled and countersunk. Supplied with steel bolts.  
**Thick:** 3 mm



## 3 PEDALS SET

OA0-1050 € 21,00 (A)

Same features as partnumber OA/1030, but the surface of the pedals is in knurled aluminium and can be shaped as needed.  
**Thick:** 2,5 mm



# CO-DRIVER ACCESSORIES

## CO-DRIVER PLUS

OBO-2980 € 60,00 (P)

Lightweight sporty bag with shoulder strap and organizational features included plenty of internal and external accessory pockets. Ideal for co-drivers.

DIMENSIONS: 40X34X20 CM



**RACING SUIT-INSPIRED  
DESIGN INSERT**



## CO-DRIVER MAP LIGHT

6400001 € 55,00 (A)

High efficiency led and flex metal boom, fixing bracket with switch. Length: 50 cm

6400002 € 55,00 (A)

High efficiency led and flex metal boom, fixing bracket with switch. Length: 40 cm

6400003 € 55,00 (A)

High efficiency led and flex metal boom, fixing bracket with switch. Length: : 30 cm



## CO-DRIVER'S PAD

NA0-1863 € 43,00 (C) NA0-1862 € 22,00 (C)

Size: A4 Size: 17,3x22cm  
Pages: 130 Pages: 100



## PROFESSIONAL

NC0-1068 € 153,00 (C)

Aluminium frame. Dimensions: 100x72 cm Complete with 42 cards of numbers, letters and symbols measuring 23x14 cm and one customizable plate 23x65 cm supplied in a synthetic leather bag, which stores sidely on the aluminium frame when not being used.



## LIQUID CRYSTAL HANDHELD STOPWATCH

NC0-1040 € 45,00 (C)

CHRONOGRAPH: with split, total elapsed times up to 9h, 59', 59", 99 seconds. CLOCK: displays hours, minutes, seconds, alarm clock with 12/24h option. TIMER: with presettable countdown timer. 60 lap memory and lap counter. Shows fastest lap, slowest lap and average lap times. 60 memory



# PIT ACCESSORIES

## TRIPLA

NC0-1067 € 125,00 (C)

Aluminium frame. Complete with 24 cards of numbers, letters and symbols measuring 23x14 cm Dimensions: 72x72 cm



## CARDS

NC0-1069 € 76,00 (C)

42 spare cards for pit boards KC/1067 and KC/1068, supplied in a synthetic leather carrying pouch.



## HANDHELD STOPWATCH

NC0-1041 € 25,00 (A)

CHRONOGRAPH: with partial and total elapsed times up to 9h 59'59"99, lap times. CLOCK: with alarm clock and Pacer dater. TIMER: with countdown function.



# STRUT BRACES

We are the leading European manufacturer of strut braces, offering over 1000 vehicle specific applications. Our strut braces are engineered to keep suspension geometry unaltered in hard cornering, while improving feedback to the drive.

## STRUT BRACES ALLUMINIUM

### MA0-1040

Extruded aluminium strut brace with adjustable ends and steel flanges.



## STRUT BRACES STEEL

### MA0-1069

Extruded aluminium strut brace with adjustable ends and steel flanges.



Consult our make/model application lists to find the product dedicated to your car. Use the QR to access our price list.

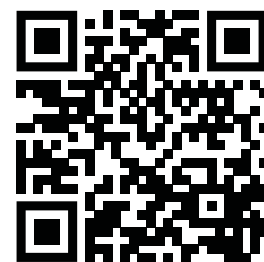

[www.ompracing.com](http://www.ompracing.com)  
and on QR code

# MOTORSPORT CARE

The expertise of two historic companies in motorsport and care respectively, mixed together for an exclusive range of products for the cleaning and maintenance of your racing gear: OMP Motorsport Care powered by MaFra.



## FIRE PAINT

PCO-08408 € 23,00 (A)

- PCO-08408 RED
- PCO-08008 BLACK
- PCO-08708 GOLD
- PCO-08108 SILVER

Transparent black acrylic paint for personalization of indicator lights.  
Contents: 400 ml



## BLACK LIGHT PAINT

PCO-42123 € 21,00 (A)

Transparent black acrylic paint for personalization of indicator lights.  
Contents: 400 ml



## MULTIPURPOSE

PCO-2005 € 11,00 (P)

- PRE-WASH DEGREASER AND STAIN REMOVER**
- High performance specific pre-wash treat for grease and oil stains
  - Helps to blast out grease and dirt from every fabric (fire retardant or karting suits, seats, steering wheels...)
  - Ultra fast action
  - Special formula with balanced ph
  - Vol. 500 ml



## SUEDE LEATHER CLEANER

PCO-2006 € 13,20 (P)

- Cleans and hydrates the suede leather of boots and steering wheels covers.
- New formula with aloe vera and natural waxes
- Revives the suede and keeps it soft
- Easy and fast to use
- Vol. 500 ml



## FABRIC CLEANER

PCO-2007 € 10,20 (P)

- Wipes off grease and dirt from your racing seats' fabric upholstery.
- Active foam eases the removal of dirt from the fibers
- Revives the fabric after the most stressing racing sessions
- Easy and fast to use
- Vol. 500 ml

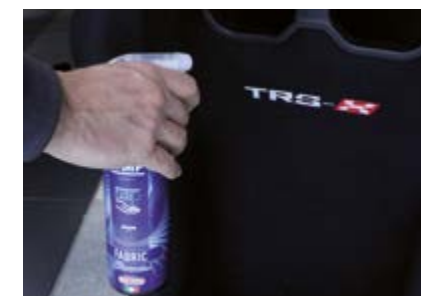
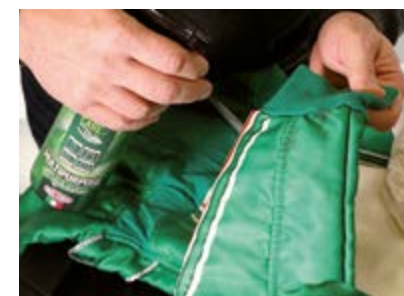

# GS OFFICE CHAIR

**UNI EN 1335-2020**

CLASS B  
**HOMOLOGATION**  
The standard for office work chairs

HAO-0835-A01

€ 259,00 (P)



HAO-00835-A01-073  
BLACK/RED



HAO-00835-A01-178  
BLACK/YELLOW



HAO-00835-A01-071  
BLACK



HAO-00835-A01-276  
BLACK VINYL WITH BREATHABLE  
AIRNET FABRIC

- Vinyl with 3D effect sewing
- High quality reclining mechanism
- Aluminium base
- 3-way adjustable arm rests
- Hydraulic height adjustment



## SPARE CUSHION

Headrest cushion  
HB0-0709  
€ 16,00 (P)



Lumbar cushion  
HB0-0708  
€ 15,00 (P)



Headrest and lumbar  
cushion HB0-0707  
€ 29,00 (P)



**UNI EN 1335-2020**

CLASS B  
**HOMOLOGATION**  
The standard for office work chairs

HAO-0836-A01

€ 279,00 (P)

- Vinyl with 3D effect sewing
- High quality reclining mechanism
- Base with colored inserts
- 4-way adjustable arm rests
- Hydraulic height adjustment



HAO-0836-A01-178  
BLACK/FLUO YELLOW



HAO-0836-A01-179  
BLACK/FLUO ORANGE



HAO-0836-A01-274  
BLACK/FLUO GREEN



HAO-0836-A01-071  
BLACK

## OPTIONAL CUSHION

Headrest cushion  
HB0-0709  
€ 16,00 (P)



Lumbar cushion  
HB0-0708  
€ 15,00 (P)



Headrest and lumbar  
cushion HB0-0707  
€ 29,00 (P)



# OMP E-RACING GTR COCKPITS

OMP started a new exclusive partnership with Playseat®, the world's leading company in racing simulation cockpits. The new OMP e-racing GTR cockpit stands out for the integration with the HTE-R or Champ-R seats, the same FIA-homologated products developed by OMP for real-world racing. The virtual driving experience becomes even closer to the real thing, by perfectly replicating the ergonomics of GT, Touring and Rally cars.

The sim racers more focused on single-seater cars can opt for the Playseat® Formula model, successfully used by many globally renowned drivers.

All the sim rigs are fully compatible with any console, steering wheel, pedal board and simulation platform on the market.



## HTE-R SEAT

ERO-0001 € 1.105,00 (D)

The OMP e-racing GTR cockpit is built around the renowned OMP seats. These racing seats used in real racing enable to replicate the ergonomics of GT, Touring and Rally cars.



## CHAMP-R SEAT

ERO-0002 € 900,00 (D)

The OMP e-racing GTR cockpit is built around the renowned OMP seats. These racing seats used in real racing enable to replicate the ergonomics of GT, Touring and Rally cars.

# OMP E-RACING COCKPITS

## FORMULA COCKPIT

ERO-0003 € 983,00 (D)

The OMP e-racing custom Formula seat is ideal for sim racers focused on single-seater cars. It has been successfully tested by many globally renowned drivers and features a dedicated OMP colour scheme.



# TERM SALE

By placing an order, the buyer accepts and unconditionally agrees with the conditions described in this document, and undertakes to follow them during the course of the business relationship with Racing Force, declaring to have read and accepted them. The buyer also agrees that Racing Force don't consider themselves bound to different conditions, except where agreed in writing in advance. The buyer accepts the terms of sale indicated below. In the event of any legal dispute, the Court of Genoa, Italy, is competent. Racing Force reserves the right to modify the terms of sales anytime, also in view of possible regulatory changes. The new Terms Of Sale will be effective starting from the date of publication on OMP Racing official website ([www.ompracing.com](http://www.ompracing.com)). For any request of clarification or complaint, contact the following email address: [info.rf@racingforce.com](mailto:info.rf@racingforce.com)

**CHARACTERISTICS AND PRICES OF PRODUCTS** The price indicated are VAT excluded. The characteristics and technical data of the items presented in this catalogue are not binding and can be changed without notice. The products' colors can also be considerably altered.

**RETURNED ITEMS – DELIVERY TIME** Racing Force is not responsible for delayed deliveries and will not pay for possible consequent damages. Returned goods will be accepted only when authorized by Racing Force, provided with regular goods return note, and carriage paid. Racing Force will charge all the costs deriving from damages on the returned goods or missing parts. Defective or not functioning items that will be returned after having been purchased will be repaired in the necessary time and will not be substituted by new ones in any way. Orders made in writing (fax, mail, e-mail, etc.) will be considered automatically confirmed and will be forwarded in accordance with the normal procedure. The goods travel at the risk of the consignee, and any damage caused during the carriage will be charged to the consignee.

**CARE AND MANTAINANCE** Before the use of any item, carefully read the labels and the user's manual, and strictly follow the instructions. Improper use or mantainance can reduce the effectiveness of the item, provoke untimely wear and increase the risk of serious or lethal injuries in case of accident or fire. Improper use or mantainance void the guarantee and relieve Racing Force from any responsibility towards the user.

# WARNING

Motorsport is an intrinsically dangerous activity, that can result in serious or lethal injuries. The items described in this catalogue provide for protection on specific parts of the body for a a limited period of time in controlled test conditions, in accordance with the FIA standard specified on each item's label. No device can provide a complete protection from every injury in case of accident or fire. The user, at the time when he uses the products, relieves the manufacturer, the distributor, the owner, the employees, the agents, the sales representatives from any responsibility. It is the user's responsibility to become familiar with all available informations about the correct use and mantainance of the products. If uncertain of the correct use and mantainance, the user must not use the products. The manufacturer, the distributor and their respective owners, employees, agents and representatives are not responsible for mistakes or omissions.

## DISCLAIMER

- Each personal safety device is part of a complete safety system including the other racewear products, protections, the vehicle, the racetrack, the event organization.  
- Personal safety products are not conceived to provide the same performance level or protection through the whole specific product. Different parts or areas of the product can provide different levels of protection, in spite of the fact that they may appear the same.  
- Personal safety products must always be inspected before use and replaced after any evidence of wear, and after exposure to chemicals, excessive heat or any unusual condition.  
- Products are sold to be used in legally sanctioned autosport events only, and are not intended to be used and/or installed for regular street use, as street use safety products are subject to different homologations and laws depending on the State or country.

- It is the user's responsibility to become familiar with all available informations about the correct use and mantainance of the products. If uncertain of the correct use and mantainance, the user must not use the products. The manufacturer, the distributor and their respective owners, employees, agents and representatives are not responsible for mistakes or omissions.  
- Every single modification or customization of the products, and every operation on them may reduce their security features. Thus, the user is responsible at his own risk for the reduction of security features caused by modification or customization.

## BY THE USE OF THESE PRODUCTS, THE USER ACKNOWLEDGES:

That each personal safety device is part of a complete safety system including the other racewear products, protections, the vehicle, the racetrack, the event organization; that personal safety products are not conceived to provide the same performance level or protection through the whole specific product. Different parts or areas of the product can provide different levels of protection, in spite of the fact that they may appear the same; that personal safety products must always be inspected before use and replaced after any evidence of wear, and after exposure to chemicals, excessive heat or any unusual condition.  
That the helmet is conceived and designed to reduce the risk of cranial and facial injuries only in case of impact. That no helmet can protect against any possible and foreseeable impact. That helmets are not recommended and sold for high-risk jobs such as refuelers. Further information at the following web addresses: [www.ompracing.com](http://www.ompracing.com) and [www.ompamerica.com](http://www.ompamerica.com)



A BRAND OF  
RACING**FORCE**GROUP



## CONTACT US

### RACING FORCE S.p.A. (Headquarter)

Via E. Bazzano, 5  
16019 Ronco Scrivia (GE) Italy  
Phone: +39 010 96501  
Fax: +39 010 935698  
Email: [info.rf@racingforce.com](mailto:info.rf@racingforce.com)  
[ompracing.com](http://ompracing.com)

### RACING FORCE USA Inc.

241 NE 61st St. Miami, FL 33137  
Phone: (305) 373-0051  
Fax: (305) 373-6673  
Toll Free: 1 866 OMP-2637  
Email: [info.usa@racingforce.com](mailto:info.usa@racingforce.com)  
[ompamerica.com](http://ompamerica.com)



### MOTORSPORT EXPORT SALES

Phone: +39 0109650150  
Fax: +39 010 935698  
Email: [exportsales.rf@racingforce.com](mailto:exportsales.rf@racingforce.com)



### MOTORSPORT ITALIAN SALES

Phone: +39 010 9650147  
Fax: +39 010 93505808  
Email: [vendite.italia@racingforce.com](mailto:vendite.italia@racingforce.com)



### KART SALES

Phone: +39 010 9650147  
Fax: +39 010 93505808  
Email: [kartsales.rf@racingforce.com](mailto:kartsales.rf@racingforce.com)



**OMP**

[ **CAR PARTS** | 2026 CATALOG ]

A BRAND OF

**RACINGFORCEGROUP**

